



★ dsb ★

SEMPLICEMENTE BICI



★ dsb ★

SEMPLICEMENTE BICI

Come molti lavori anche quello del distributore bici sta diventando un lavoro sempre più complicato.

Alcuni stagioni addietro pensavo che dovessimo smettere con le bici e dedicarci in maniera esclusiva agli accessori. Vedevo che tutti i miei concorrenti, stavano lasciando le bici perché troppo rischiose. Poi alcune aziende importanti di accessori ci hanno lasciato ed aver avuto le bici in quel periodo è stata la salvezza.

Due stagioni fa le bici hanno preso il predominio di DSB e allora vai ad eliminare marchi di accessori che non rendevano.

Mi dicevo: Davide stai focalizzato, fai focalizzare gli agenti e vedrai che tutto andrà al meglio.

Sulla carta tutto giusto.

Nella realtà non altrettanto.

Perché dimentico sempre che DSB non è un'azienda fondamentale per i rivenditori con cui lavoro.

Importante, sì, per alcuni, ma mai essenziale.

E quando non sei essenziale devi sempre faticare il doppio per trovare il tuo spazio.

Spazio, appunto che cambia in ogni stagione in base ai marchi che abbiamo ed ai prodotti giusti o sbagliati, che questi marchi propongono.

Dobbiamo stare sempre superconcentrati. Io per non fare troppe minchiate, per cercare sempre nuovi prodotti.

La mia rete vendita che deve proporre questi prodotti ai rivenditori.

Ed allo stesso tempo tenere viva la vostra attenzione.

Ed è per questo che il catalogo ha riferimento l'erba.

Perché se la bagni regolarmente, la tieni curata, togli le infestanti e la tagli, avrai sempre un prato splendido.

Ma appena ti dimentichi e non poni più la stessa attenzione ti trovi il deserto.

Questo catalogo è appunto erba nuova e ben curata.

Abbiamo reinserito le bici, abbiamo aggiunto nuovi marchi di accessori (e ne mancano alcuni di cui abbiamo definito la distribuzione troppo tardi per poter essere inseriti), siamo tornati a scrivere brevi storie affinché vi venga voglia di conservarlo.

Insomma un sacco di super lavoro.

Un sacco di tempo e fatica per una struttura piccola come DSB.

Un catalogo dedicato in toto a voi appassionati che siete da sempre il mio humus personale di crescita.

Non c'è giorno che non mi incazzi.

Non c'è giorno altresì che non impari qualcosa.

E imparare non è crescere?

Buona lettura

Davide Bonandrini

SANTA CRUZ - JULIANA

4

64

MONDRAKER

YETI

112

140

ROCKY MOUNTAIN

EVIL

170

180

OPEN

AFTON

188

190

ALPINESTARS

BRAKE AUTHORITY

202

204

HIPLOK

HOPE

208

216

INDUSTRY NINE

LIZARD SKINS

220

226

LUMOS

MUCKY NUTZ

228

230

ORTILIEB WATERPROOF

RACE FACE

236

250

RESERVE

RESOLVBIKE

252

254

SCOPE

SDG

256

260

SOURCE

THOMSON

264

268

TLD TROY LEE DESIGNS

URGE

270

SANTA CRUZ



Juliana



★ d s b ★

SEMPLICEMENTE BICI



Santa Cruz è un marchio di nicchia con una vocazione formidabile: sa costruire bici che diventano delle icone. Come ci riesce?

Non è solo una questione di stile, immagine e di nomi, ma soprattutto di qualità.

In Santa Cruz sanno come fare i telai in fibra di carbonio. Sanno come costruire sospensioni di altissimo livello. Studiano e rivoluzionano le geometrie e creano nuovi piccoli trend da seguire. Un telaio Santa Cruz è una fonte di divertimento senza fine ed è un pezzo di storia importante della mountain bike.

Mettetevi comodi, girate pagina ed entrate...

TALLBOY

La Tallboy rende il confine tra XC e trail riding meno netto grazie a un'escursione posteriore di 110 mm e all'adozione di una gomma veloce da 29" o una presa eccezionale con una gomma 650b Plus. Con la prima abbiamo una forcella da 120 mm e con la seconda arriviamo fino a 130. "Trail country" per pedigree, la Tallboy si arrampica bene quasi come una XC, ma si comporta come una trail sulle discese. Nonostante i soli 110 mm di travel la sensazione che trasmette è di estrema confidenza. Il telaio con escursione corta ne consente un controllo di precisione con grande agilità.

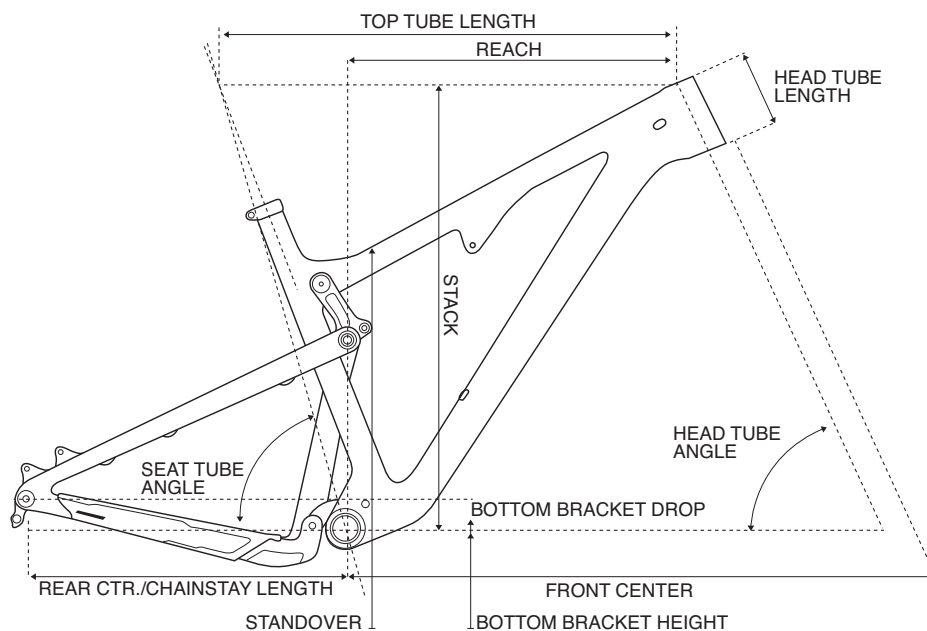

GEOMETRIA	S (27.5+/29)	M (27.5+/29)	L (27.5+/29)	XL (27.5+/29)	XXL (27.5+/29)
Reach	403 / 405mm	428 / 430mm	448 / 450mm	473 / 475mm	503 / 505mm
Stack	595 / 594mm	605 / 603mm	605 / 603mm	619 / 617mm	633 / 631mm
Head Tube Angle	68 / 68°	68 / 68°	68 / 68°	68 / 68°	68 / 68°
Head Tube Length	90 / 90mm	100 / 100mm	100 / 100mm	115 / 115mm	130 / 130mm
Seat Tube Angle	73 / 73°	73 / 73°	73 / 73°	73 / 73°	73 / 73°
Seat Tube Length	390 / 390mm	420 / 420mm	450 / 450mm	480 / 480mm	510 / 510mm
Rear Center	432 / 432mm	432 / 432mm	432 / 432mm	432 / 432mm	432 / 432mm
Front Center	687 / 684mm	716 / 713mm	736 / 733mm	767 / 763mm	802 / 799mm
BB Height	328 / 330mm	328 / 330mm	328 / 330mm	328 / 330mm	328 / 330mm
BB Drop	33 / 40mm	33 / 40mm	33 / 40mm	33 / 40mm	33 / 40mm
Top Tube Length	575 / 574mm	604 / 603mm	624 / 623mm	654 / 653mm	689 / 689mm
Standover	702 / 705mm	703 / 706mm	704 / 707mm	706 / 709mm	700 / 704mm

CARATTERISTICHE

- 110 mm di escursione VPP.
- Pneumatici convertibili tra 29 e 27,5+.
- Opzione cerchi Santa Cruz Reserve 27 in carbonio sulle bici CC.
- Disponibile in carbonio CC e carbonio C.
- Garanzia a vita per telaio e cuscinetti.
- Perfetta per: endurance racing e percorsi all-around.
- A suo agio su: terreni da fluidi a moderatamente aggressivi.
- Taglie: S, M, L, XL, XXL.
- Peso: 11,96-14,36 kg.
- Solo telaio/ammortizzatore a partire da: 2,52 kg.
- Colore: Gloss Black/Tan - Gloss Rust/Black.



TALLBOY CC
XX1 29TALLBOY CC
XX1 29 RESERVETALLBOY CC
XX1 27+TALLBOY CC
XX1 27+ ENVE

	TALLBOY CC XX1 29	TALLBOY CC XX1 29 RESERVE	TALLBOY CC XX1 27+	TALLBOY CC XX1 27+ ENVE
Frame	Carbon CC 29/27+110mm Travel VPP™	Carbon CC 29/27+110mm Travel VPP™	Carbon CC 29/27+110mm Travel VPP™	Carbon CC 29/27+110mm Travel VPP™
Shock	FOX Float Factory DPS Kashima	FOX Float Factory DPS Kashima	FOX Float Factory DPS Kashima	FOX Float Factory DPS Kashima
Fork	FOX 34 Float Factory 120	FOX 34 Float Factory 120	FOX 34 Float Factory 130	FOX 34 Float Factory 130
R. Derailleur	SRAM XX1 Eagle 12 speed	SRAM XX1 Eagle 12 speed	SRAM XX1 Eagle 12 speed	SRAM XX1 Eagle 12 speed
F. Derailleur	N/A	N/A	N/A	N/A
Chainguide	N/A	N/A	N/A	N/A
Shifters	SRAM XX1 Eagle 12 speed	SRAM XX1 Eagle 12 speed	SRAM XX1 Eagle 12 speed	SRAM XX1 Eagle 12 speed
Brakes	SRAM Level Ultimate	SRAM Level Ultimate	SRAM Level Ultimate	SRAM Level Ultimate
Rotors	Avid Centerline - 180mm	Avid Centerline - 180mm	Avid Centerline - 180mm	Avid Centerline - 180mm
Crankset	SRAM XX1 Eagle 32t - 170mm (S), 175mm (M-XXL)	SRAM XX1 Eagle 32t - 170mm (S), 175mm (M-XXL)	SRAM XX1 Eagle 32t - 170mm (S), 175mm (M-XXL)	SRAM XX1 Eagle 32t - 170mm (S), 175mm (M-XXL)
Cassette	SRAM XG1295 Eagle 10-50t	SRAM XG1295 Eagle 10-50t	SRAM XG1295 Eagle 10-50t	SRAM XG1295 Eagle 10-50t
Chain	SRAM XX1 Eagle 12 speed	SRAM XX1 Eagle 12 speed	SRAM XX1 Eagle 12 speed	SRAM XX1 Eagle 12 speed
Handlebar	Santa Cruz XC Carbon - 31.8x750mm (S-M), 780mm (L-XXL)	Santa Cruz XC Carbon - 31.8x750mm (S-M), 780mm (L-XXL)	Santa Cruz XC Carbon - 31.8x750mm (S-M), 780mm (L-XXL)	Santa Cruz XC Carbon - 31.8x750mm (S-M), 780mm (L-XXL)
Stem	Easton Haven - 55mm	Easton Haven - 55mm	Easton Haven - 55mm	Easton Haven - 55mm
Grips	Santa Cruz Palmdale Grips - Black	Santa Cruz Palmdale Grips - Black	Santa Cruz Palmdale Grips - Black	Santa Cruz Palmdale Grips - Black
Headset	Cane Creek 110 IS Integrated Headset	Cane Creek 110 IS Integrated Headset	Cane Creek 110 IS Integrated Headset	Cane Creek 110 IS Integrated Headset
Seatpost	RockShox Reverb Stealth - 31.6x125mm (S), 150mm (M-L), 170mm (XL-XXL)	RockShox Reverb Stealth - 31.6x125mm (S), 150mm (M-L), 170mm (XL-XXL)	RockShox Reverb Stealth - 31.6x125mm (S), 150mm (M-L), 170mm (XL-XXL)	RockShox Reverb Stealth - 31.6x125mm (S), 150mm (M-L), 170mm (XL-XXL)
Saddle	WTB Silverado SLT	WTB Silverado SLT	WTB Silverado SLT	WTB Silverado SLT
Front Tire	Maxxis Minion DHF 3C EXO TR 29x2.3"	Maxxis Minion DHF 3C EXO TR 29x2.3"	Maxxis Rekon EXO 3C TR - 27.5x2.8"	Maxxis Rekon EXO 3C TR - 27.5x2.8"
Rear Tire	Maxxis Ardent Race EXO TR 29x2.35"	Maxxis Ardent Race EXO TR 29x2.35"	Maxxis Rekon EXO TR - 27.5x2.8"	Maxxis Rekon EXO TR - 27.5x2.8"
 Tubes/Sealant	Stan's Sealant	Stan's Sealant	Stan's Sealant	Stan's Sealant
Front Hub	i9 Torch Classic - 15x110mm, 28h	i9 Torch Classic - 15x110mm, 28h	i9 Torch Classic - 15x110mm, 28h	DT 350 - 15x110mm, 28h
Rear Hub	i9 Torch Classic - 12x148mm, 28h (XD)	i9 Torch Classic - 12x148mm, 28h (XD)	i9 Torch Classic - 12x148mm, 28h (XD)	i9 Torch Classic - 12x148mm, 28h (XD)
Rim	Race Face ARC 24 - 28h	Santa Cruz Reserve 27 Carbon - 28h	Race Face ARC 40 - 28h	ENVE M60 Forty Plus
Spokes	DT Competition	DT Competition Race	DT Competition	DT Competition Race
Prezzo telaio	€3.499,00	€3.499,00	€3.499,00	€3.499,00
Prezzo bici	€8.599,00	€9.999,00	€8.699,00	€10.999,00

TALLBOY CC
X01 29TALLBOY CC
X01 29 RESERVETALLBOY CC
X01 27+TALLBOY CC
X01 27+ ENVE

	TALLBOY CC X01 29	TALLBOY CC X01 29 RESERVE	TALLBOY CC X01 27+	TALLBOY CC X01 27+ ENVE
Frame	Carbon CC 29/27+ 110mm Travel VPP™	Carbon CC 29/27+ 110mm Travel VPP™	Carbon CC 29/27+ 110mm Travel VPP™	Carbon CC 29/27+ 110mm Travel VPP™
Shock	FOX Float Performance Elite DPS	FOX Float Performance Elite DPS	FOX Float Performance Elite DPS	FOX Float Performance Elite DPS
Fork	FOX 34 Float Performance Elite 120	FOX 34 Float Performance Elite 120	FOX 34 Float Performance Elite 130	FOX 34 Float Performance Elite 130
R. Derailleur	SRAM X01 Eagle 12 speed	SRAM X01 Eagle 12 speed	SRAM X01 Eagle 12 speed	SRAM X01 Eagle 12 speed
F. Derailleur	N/A	N/A	N/A	N/A
Chainguide	N/A	N/A	N/A	N/A
Shifters	SRAM X01 Eagle	SRAM X01 Eagle	SRAM X01 Eagle	SRAM X01 Eagle
Brakes	SRAM Level TLM	SRAM Level TLM	SRAM Level TLM	SRAM Level TLM
Rotors	Avid Centerline - 180mm	Avid Centerline - 180mm	Avid Centerline - 180mm	Avid Centerline - 180mm
Crankset	SRAM X1 Eagle Carbon 32t - 170mm (S), 175mm (M-XXL)	SRAM X1 Eagle Carbon 32t - 170mm (S), 175mm (M-XXL)	SRAM X1 Eagle Carbon 32t - 170mm (S), 175mm (M-XXL)	SRAM X1 Eagle Carbon 32t - 170mm (S), 175mm (M-XXL)
Cassette	SRAM XG1295 Eagle 10-50t	SRAM XG1295 Eagle 10-50t	SRAM XG1295 Eagle 10-50t	SRAM XG1295 Eagle 10-50t
Chain	SRAM X01 Eagle 12 speed	SRAM X01 Eagle 12 speed	SRAM X01 Eagle 12 speed	SRAM X01 Eagle 12 speed
Handlebar	Santa Cruz XC Carbon - 31.8x750mm (S-M), 780mm (L-XXL)	Santa Cruz XC Carbon - 31.8x750mm (S-M), 780mm (L-XXL)	Santa Cruz XC Carbon - 31.8x750mm (S-M), 780mm (L-XXL)	Santa Cruz XC Carbon - 31.8x750mm (S-M), 780mm (L-XXL)
Stem	Easton Haven - 55mm	Easton Haven - 55mm	Easton Haven - 55mm	Easton Haven - 55mm
Grips	Santa Cruz Palmdale Grips - Black	Santa Cruz Palmdale Grips - Black	Santa Cruz Palmdale Grips - Black	Santa Cruz Palmdale Grips - Black
Headset	Cane Creek 40 IS Integrated Headset	Cane Creek 40 IS Integrated Headset	Cane Creek 40 IS Integrated Headset	Cane Creek 40 IS Integrated Headset
Seatpost	RockShox Reverb Stealth - 31.6x125mm (S), 150mm (M-L), 170mm (XL-XXL)	RockShox Reverb Stealth - 31.6x125mm (S), 150mm (M-L), 170mm (XL-XXL)	RockShox Reverb Stealth - 31.6x125mm (S), 150mm (M-L), 170mm (XL-XXL)	RockShox Reverb Stealth - 31.6x125mm (S), 150mm (M-L), 170mm (XL-XXL)
Saddle	WTB Silverado Pro	WTB Silverado Pro	WTB Silverado Pro	WTB Silverado Pro
Front Tire	Maxxis Minion DHF 3C EXO TR 29x2.3"	Maxxis Minion DHF 3C EXO TR 29x2.3"	Maxxis Rekon EXO 3C TR - 27.5x2.8"	Maxxis Rekon EXO 3C TR - 27.5x2.8"
Rear Tire	Maxxis Ardent Race EXO TR 29x2.35"	Maxxis Ardent Race EXO TR 29x2.35"	Maxxis Rekon EXO TR - 27.5x2.8"	Maxxis Rekon EXO TR - 27.5x2.8"
 Tubes/Sealant	Stan's Sealant	Stan's Sealant	Stan's Sealant	Stan's Sealant
Front Hub	DT 350 - 15x110mm, 28h	DT 350 - 15x110mm, 28h	DT 350 - 15x110mm, 28h	DT 350 - 15x110mm, 28h
Rear Hub	DT 350 - 12x148mm, 28h (XD)	DT 350 - 12x148mm, 28h (XD)	DT 350 - 12x148mm, 28h (XD)	DT 350 - 12x148mm, 28h (XD)
Rim	Race Face ARC 24 - 28h	Santa Cruz Reserve 27 Carbon - 28h	Race Face ARC 40 - 28h	ENVE M60 Forty Plus
Spokes	DT Competition	DT Competition Race	DT Competition	DT Competition Race
Prezzo telaio	€3.499,00	€3.499,00	€3.499,00	€3.499,00
Prezzo bici	€7.199,00	€8.599,00	€7.199,00	€9.799,00

TALLBOY C
XE 29TALLBOY C
XE 27+

Frame	Carbon C 29/27+ 110mm Travel VPP™	Carbon C 29/27+ 110mm Travel VPP™
Shock	FOX Float Performance Elite DPS	FOX Float Performance Elite DPS
Fork	FOX 34 Float Performance Elite 120	FOX 34 Float Performance Elite 130
R. Derailleur	Shimano XT M8000	Shimano XT M8000
F. Derailleur	N/A	N/A
Chainguide	N/A	N/A
Shifters	Shimano XT M8000	Shimano XT M8000
Brakes	Shimano XT M8000	Shimano XT M8000
Rotors	Shimano RT86 Ice Tech - 180mm	Shimano RT86 Ice Tech - 180mm
Crankset	Race Face Turbine 30t - 170mm (S), 175mm (M-XXL)	Race Face Turbine 30t - 170mm (S), 175mm (M-XXL)
Cassette	E13 TRS Race 11 speed 9-46t	E13 TRS Race 11 speed 9-46t
Chain	Shimano SLX M7000	Shimano SLX M7000
Handlebar	Santa Cruz XC Carbon - 31.8x750mm (S-M), 780mm (L-XXL)	Santa Cruz XC Carbon - 31.8x750mm (S-M), 780mm (L-XXL)
Stem	Race Face Turbine Basic - 50mm	Race Face Turbine Basic - 50mm
Grips	Santa Cruz Palmdale Grips - Black	Santa Cruz Palmdale Grips - Black
Headset	Cane Creek 40 IS Integrated Headset	Cane Creek 40 IS Integrated Headset
Seatpost	RockShox Reverb Stealth - 31.6x125mm (S), 150mm (M-L), 170mm (XL-XXL)	RockShox Reverb Stealth - 31.6x125mm (S), 150mm (M-L), 170mm (XL-XXL)
Saddle	WTB Silverado Pro	WTB Silverado Pro
Front Tire	Maxxis Minion DHF 3C EXO TR 29x2.3"	Maxxis Rekon EXO 3C TR - 27.5x2.8"
Rear Tire	Maxxis Ardent Race EXO TR 29x2.35"	Maxxis Rekon EXO TR - 27.5x2.8"
Tubes/Sealant	Stan's Sealant	Stan's Sealant
Front Hub	Novatec D641 - 15x110mm	Novatec D641 - 15x110mm
Rear Hub	Novatec D642 - 12x148mm (XD)	Novatec D642 - 12x148mm (XD)
Rim	Race Face AR 24 - 32h	Race Face AR 40 - 32h
Spokes	DT Competition	DT Competition
Prezzo bici	€ 5.999,00	€ 5.999,00

TALLBOY C
R 29TALLBOY C
R 27+TALLBOY C
S 29TALLBOY C
S 27+

	TALLBOY C R 29	TALLBOY C R 27+	TALLBOY C S 29	TALLBOY C S 27+
Frame	Carbon C 29/27+ 110mm Travel VPP™	Carbon C 29/27+ 110mm Travel VPP™	Carbon C 29/27+ 110mm Travel VPP™	Carbon C 29/27+ 110mm Travel VPP™
Shock	FOX Float Performance DPS	FOX Float Performance DPS	FOX Float Performance DPS	FOX Float Performance DPS
Fork	FOX Rhythm 34 120	FOX Rhythm 34 130	FOX 34 Float Performance 120	FOX 34 Float Performance 130
R. Derailleur	SRAM NX 11spd Long Cage	SRAM NX 11 speed Long Cage	SRAM GX Eagle 12 speed	SRAM GX Eagle 12 speed
F. Derailleur	N/A	N/A	N/A	N/A
Chainguide	N/A	N/A	N/A	N/A
Shifters	SRAM NX 11 speed	SRAM NX 11 speed	SRAM GX Eagle 12 speed	SRAM GX Eagle 12 speed
Brakes	SRAM Level T	SRAM Level T	SRAM Level TL	SRAM Level TL
Rotors	Avid Centerline - 180mm	Avid Centerline - 180mm	Avid Centerline - 180mm	Avid Centerline - 180mm
Crankset	Race Face Aeffect 30t - 170mm (S), 175mm (M-XXL)	Race Face Aeffect 30t - 170mm (S), 175mm (M-XXL)	SRAM GX Eagle 32t - 170mm (S), 175mm (M-XXL)	SRAM GX Eagle 32t - 170mm (S), 175mm (M-XXL)
Cassette	SRAM XG1150 CS 10-42T	SRAM XG1150 CS 10-42t	SRAM XG1275 Eagle 10-50t	SRAM XG1275 Eagle 10-50t
Chain	SRAM PC1110	SRAM PC1110	SRAM GX Eagle 12 speed	SRAM GX Eagle 12 speed
Handlebar	Race Face Ride Lo-Rise - 35x760mm	Race Face Ride Lo-Rise - 35x760mm	Race Face Ride Lo-Rise - 35x760mm	Race Face Ride Lo-Rise - 35x760mm
Stem	Race Face Ride - 50mm	Race Face Ride - 50mm	Race Face Aeffect R - 50mm	Race Face Aeffect R - 50mm
Grips	Santa Cruz Palmdale Grips - Black	Santa Cruz Palmdale Grips - Black	Santa Cruz Palmdale Grips - Black	Santa Cruz Palmdale Grips - Black
Headset	Cane Creek 10 IS Integrated Headset	Cane Creek 10 IS Integrated Headset	Cane Creek 40 IS Integrated Headset	Cane Creek 40 IS Integrated Headset
Seatpost	Race Face Aeffect - 31.6x125mm (S-M), 150mm (L-XXL)	Race Face Aeffect - 31.6x125mm (S-M), 150mm (L-XXL)	RockShox Reverb Stealth - 31.6x125mm (S), 150mm (M-L), 170mm (XL-XXL)	RockShox Reverb Stealth - 31.6x125mm (S), 150mm (M-L), 170mm (XL-XXL)
Saddle	WTB Volt Race	WTB Volt Race	WTB Volt Race	WTB Volt Race
Front Tire	Maxxis Minion DHF EXO TR - 29x2.3"	Maxxis Rekon EXO TR - 27.5x2.8"	Maxxis Minion DHF 3C EXO TR 29x2.3"	Maxxis Rekon EXO 3C TR - 27.5x2.8"
Rear Tire	Maxxis Crossmark II DC EXO TR 29x2.25"	Maxxis Rekon EXO TR - 27.5x2.8"	Maxxis Ardent Race EXO TR 29x2.35"	Maxxis Rekon EXO TR - 27.5x2.8"
 Tubes/Sealant	Stan's Sealant	Stan's Sealant	Stan's Sealant	Stan's Sealant
Front Hub	Novatec D711 - 15x110mm	Novatec D711 - 15x110mm	Novatec D641 - 15x110mm	Novatec D641 - 15x110mm
Rear Hub	Novatec D462 - 12x148mm (XD)	Novatec D462 - 12x148mm (XD)	Novatec D642 - 12x148mm (XD)	Novatec D642 - 12x148mm (XD)
Rim	WTB ST i23 TCS	Race Face AR 40 - 32h	Race Face AR 24 - 32h	Race Face AR 40 - 32h
Spokes	DT Competition	DT Competition	DT Competition	DT Competition
Prezzo bici	€4.499,00	€4.499,00	€5.199,00	€5.199,00

TALLBOY A
D 29TALLBOY A
D 27+TALLBOY A
R 29TALLBOY A
R 27+

	TALLBOY A D 29	TALLBOY A D 27+	TALLBOY A R 29	TALLBOY A R 27+
Frame	Aluminum 29/27+ 110mm Travel VPP™	Aluminum 29/27+ 110mm Travel VPP™	Aluminum 29/27+ 110mm Travel VPP™	Aluminum 29/27+ 110mm Travel VPP™
Shock	FOX Float Performance DPS	FOX Float Performance DPS	FOX Float Performance DPS	FOX Float Performance DPS
Fork	RockShox Recon RL 120	RockShox Recon RL 130	FOX Rhythm 34 120	FOX Rhythm 34 130
R. Derailleur	SRAM NX 11 speed Long Cage	SRAM NX 11 speed Long Cage	SRAM NX 11 speed Long Cage	SRAM NX 11 speed Long Cage
F. Derailleur	N/A	N/A	N/A	N/A
Chainguide	N/A	N/A	N/A	N/A
Shifters	SRAM NX 11 speed	SRAM NX 11 speed	SRAM NX 11 speed	SRAM NX 11 speed
Brakes	SRAM Level	SRAM Level	SRAM Level T	SRAM Level T
Rotors	Avid Centerline - 180mm	Avid Centerline - 180mm	Avid Centerline - 180mm	Avid Centerline - 180mm
Crankset	Race Face Aeffect 30t - 170mm (S), 175mm (M-XXL)	Race Face Aeffect 30t - 170mm (S), 175mm (M-XXL)	Race Face Aeffect 30t - 170mm (S), 175mm (M-XXL)	Race Face Aeffect 30t - 170mm (S), 175mm (M-XXL)
Cassette	SRAM PG1130 11-42t	SRAM PG1130 11-42t	SRAM XG1150 CS 10-42T	SRAM XG1150 CS 10-42T
Chain	SRAM PC1110	SRAM PC1110	SRAM PC1110	SRAM PC1110
Handlebar	Race Face Ride Lo-Rise - 35x760mm	Race Face Ride Lo-Rise - 35x760mm	Race Face Ride Lo-Rise - 35x760mm	Race Face Ride Lo-Rise - 35x760mm
Stem	Race Face Ride - 50mm	Race Face Ride - 50mm	Race Face Ride - 50mm	Race Face Ride - 50mm
Grips	Santa Cruz Palmdale Grips - Black	Santa Cruz Palmdale Grips - Black	Santa Cruz Palmdale Grips - Black	Santa Cruz Palmdale Grips - Black
Headset	Cane Creek 10 IS Integrated Headset	Cane Creek 10 IS Integrated Headset	Cane Creek 10 IS Integrated Headset	Cane Creek 10 IS Integrated Headset
Seatpost	Race Face Ride	Race Face Ride	Race Face Aeffect - 31.6x125mm (S-M), 150mm (L-XXL)	Race Face Aeffect - 31.6x125mm (S-M), 150mm (L-XXL)
Saddle	WTB Volt Sport	WTB Volt Sport	WTB Volt Race	WTB Volt Race
Front Tire	Maxxis Minion DHF EXO TR - 29x2.3"	Maxxis Rekon EXO TR - 27.5x2.8"	Maxxis Minion DHF EXO TR - 29x2.3"	Maxxis Rekon EXO TR - 27.5x2.8"
Rear Tire	Maxxis Crossmark II DC EXO TR 29X2.25"	Maxxis Rekon EXO TR - 27.5x2.8"	Maxxis Crossmark II DC EXO TR 29X2.25"	Maxxis Rekon EXO TR - 27.5x2.8"
 Tubes/Sealant	Stan's Sealant	Stan's Sealant	Stan's Sealant	Stan's Sealant
Front Hub	Novatec D711 - 15x110mm	Novatec D711 - 15x110mm	Novatec D711 - 15x110mm	Novatec D711 - 15x110mm
Rear Hub	Novatec D462 - 12x148mm (HG)	Novatec D462 - 12x148mm (HG)	Novatec D462 - 12x148mm (XD)	Novatec D462 - 12x148mm (XD)
Rim	WTB ST i23 TCS	Race Face AR 40 - 32h	WTB ST i23 TCS	Race Face AR 40 - 32h
Spokes	DT Competition	DT Competition	DT Competition	DT Competition
Prezzo telaio	€2.299,00	€2.299,00	€2.299,00	€2.299,00
Prezzo bici	€3.299,00	€3.399,00	€3.899,00	€3.999,00

Juliana

JOPLIN CC XX1 29 RESERVE



JOPLIN CC
XX1 29

JOPLIN CC
XX1 29 RESERVE

JOPLIN CC
XX1 27+

JOPLIN CC
XX1 27+ ENVE

	JOPLIN CC XX1 29	JOPLIN CC XX1 29 RESERVE	JOPLIN CC XX1 27+	JOPLIN CC XX1 27+ ENVE
Frame	Carbon CC 29/27+ 110mm Travel VPP™	Carbon CC 29/27+ 110mm Travel VPP™	Carbon CC 29/27+ 110mm Travel VPP™	Carbon CC 29/27+ 110mm Travel VPP™
Shock	FOX Float Factory DPS Kashima	FOX Float Factory DPS Kashima	FOX Float Factory DPS Kashima	FOX Float Factory DPS Kashima
Fork	FOX 34 Float Factory 120	FOX 34 Float Factory 120	FOX 34 Float Factory 130	FOX 34 Float Factory 130
R. Derailleur	SRAM XX1 Eagle 12 speed	SRAM XX1 Eagle 12 speed	SRAM XX1 Eagle 12 speed	SRAM XX1 Eagle 12 speed
F. Derailleur	N/A	N/A	N/A	N/A
Chainguide	N/A	N/A	N/A	N/A
Shifters	SRAM XX1 Eagle 12 speed	SRAM XX1 Eagle 12 speed	SRAM XX1 Eagle 12 speed	SRAM XX1 Eagle 12 speed
Brakes	SRAM Level Ultimate	SRAM Level Ultimate	SRAM Level Ultimate	SRAM Level Ultimate
Rotors	Avid Centerline - 180mm	Avid Centerline - 180mm	Avid Centerline - 180mm	Avid Centerline - 180mm
Crankset	SRAM XX1 Eagle 30t - 170mm (S), 175mm (M-L)	SRAM XX1 Eagle 30t - 170mm (S), 175mm (M-L)	SRAM XX1 Eagle 30t - 170mm (S), 175mm (M-L)	SRAM XX1 Eagle 30t - 170mm (S), 175mm (M-L)
Cassette	SRAM XG1295 Eagle 10-50t	SRAM XG1295 Eagle 10-50t	SRAM XG1295 Eagle 10-50t	SRAM XG1295 Eagle 10-50t
Chain	SRAM XX1 Eagle 12 speed	SRAM XX1 Eagle 12 speed	SRAM XX1 Eagle 12 speed	SRAM XX1 Eagle 12 speed
Handlebar	Santa Cruz XC Carbon - 31.8 x 750mm	Santa Cruz XC Carbon - 31.8 x 750mm	Santa Cruz XC Carbon - 31.8 x 750mm	Santa Cruz XC Carbon - 31.8 x 750mm
Stem	Easton Haven - 55mm	Easton Haven - 55mm	Easton Haven - 55mm	Easton Haven - 55mm
Grips	Juliana grips - Coral	Juliana grips - Coral	Juliana grips - Coral	Juliana grips - Coral
Headset	Cane Creek 110 IS Integrated Headset	Cane Creek 110 IS Integrated Headset	Cane Creek 110 IS Integrated Headset	Cane Creek 110 IS Integrated Headset
Seatpost	RockShox Reverb Stealth - 31.6x125mm (S), 150mm (M-L)	RockShox Reverb Stealth - 31.6x125mm (S), 150mm (M-L)	RockShox Reverb Stealth - 31.6x125mm (S), 150mm (M-L)	RockShox Reverb Stealth - 31.6x125mm (S), 150mm (M-L)
Saddle	Juliana Carbon	Juliana Carbon	Juliana Carbon	Juliana Carbon
Front Tire	Maxxis Minion DHF 3C EXO TR 29x2.3"	Maxxis Minion DHF 3C EXO TR 29x2.3"	Maxxis Rekon EXO 3C TR - 27.5x2.8"	Maxxis Rekon EXO 3C TR - 27.5x2.8"
Rear Tire	Maxxis Ardent Race EXO TR 29x2.35"	Maxxis Ardent Race EXO TR 29x2.35"	Maxxis Rekon EXO TR - 27.5x2.8"	Maxxis Rekon EXO TR - 27.5x2.8"
 Tubes/Sealant	Stan's Sealant	Stan's Sealant	Stan's Sealant	Stan's Sealant
Front Hub	i9 Torch Classic - 15x110mm, 28h	i9 Torch Classic - 15x110mm, 28h	i9 Torch Classic - 15x110mm, 28h	i9 Torch Classic - 15x110mm, 28h
Rear Hub	i9 Torch Classic - 12x148mm, 28h (XD)	i9 Torch Classic - 12x148mm, 28h (XD)	i9 Torch Classic - 12x148mm, 28h (XD)	i9 Torch Classic - 12x148mm, 28h (XD)
Rim	Race Face ARC 24 - 28h	Santa Cruz Reserve 27 Carbon - 28h	Race Face ARC 40 - 28h	ENVE M60 Forty Plus
Spokes	DT Competition	DT Competition Race	DT Competition	DT Competition Race
Prezzo telaio	€3.499,00	€3.499,00	€3.499,00	€3.499,00
Prezzo bici	€8.599,00	€9.999,00	€8.699,00	€10.999,00



JOPLIN CC
X01 29

JOPLIN CC
X01 29 RESERVE

JOPLIN CC
X01 27+

JOPLIN CC
X01 27+ ENVE

	JOPLIN CC X01 29	JOPLIN CC X01 29 RESERVE	JOPLIN CC X01 27+	JOPLIN CC X01 27+ ENVE
Frame	Carbon CC 29/27+ 110mm Travel VPP™	Carbon CC 29/27+ 110mm Travel VPP™	Carbon CC 29/27+ 110mm Travel VPP™	Carbon CC 29/27+ 110mm Travel VPP™
Shock	FOX Float Performance Elite DPS	FOX Float Performance Elite DPS	FOX Float Performance Elite DPS	FOX Float Performance Elite DPS
Fork	FOX 34 Float Performance Elite 120	FOX 34 Float Performance Elite 120	FOX 34 Float Performance Elite 130	FOX 34 Float Performance Elite 130
R. Derailleur	SRAM X01 Eagle 12 speed	SRAM X01 Eagle 12 speed	SRAM X01 Eagle 12 speed	SRAM X01 Eagle 12 speed
F. Derailleur	N/A	N/A	N/A	N/A
Chainguide	N/A	N/A	N/A	N/A
Shifters	SRAM X01 Eagle	SRAM X01 Eagle	SRAM X01 Eagle	SRAM X01 Eagle
Brakes	SRAM Level TLM	SRAM Level TLM	SRAM Level TLM	SRAM Level TLM
Rotors	Avid Centerline - 180mm	Avid Centerline - 180mm	Avid Centerline - 180mm	Avid Centerline - 180mm
Crankset	SRAM X1 Eagle Carbon 30t - 170mm (S), 175mm (M-L)	SRAM X1 Eagle Carbon 30t - 170mm (S), 175mm (M-L)	SRAM X1 Eagle Carbon 30t - 170mm (S), 175mm (M-L)	SRAM X1 Eagle Carbon 30t - 170mm (S), 175mm (M-L)
Cassette	SRAM XG1295 Eagle 10-50t	SRAM XG1295 Eagle 10-50t	SRAM XG1295 Eagle 10-50t	SRAM XG1295 Eagle 10-50t
Chain	SRAM X01 Eagle 12 speed	SRAM X01 Eagle 12 speed	SRAM X01 Eagle 12 speed	SRAM X01 Eagle 12 speed
Handlebar	Santa Cruz XC Carbon - 31.8 x 750mm	Santa Cruz XC Carbon - 31.8 x 750mm	Santa Cruz XC Carbon - 31.8 x 750mm	Santa Cruz XC Carbon - 31.8 x 750mm
Stem	Easton Haven - 55mm	Easton Haven - 55mm	Easton Haven - 55mm	Easton Haven - 55mm
Grips	Juliana grips - Coral	Juliana grips - Coral	Juliana grips - Coral	Juliana grips - Coral
Headset	Cane Creek 40 IS Integrated Headset	Cane Creek 40 IS Integrated Headset	Cane Creek 40 IS Integrated Headset	Cane Creek 40 IS Integrated Headset
Seatpost	RockShox Reverb Stealth 31.6x125mm (S), 150mm (M-L)	RockShox Reverb Stealth 31.6x125mm (S), 150mm (M-L)	RockShox Reverb Stealth 31.6x125mm (S), 150mm (M-L)	RockShox Reverb Stealth 31.6x125mm (S), 150mm (M-L)
Saddle	Juliana Primiero	Juliana Primiero	Juliana Primiero	Juliana Primiero
Front Tire	Maxxis Minion DHF 3C EXO TR 29x2.3"	Maxxis Minion DHF 3C EXO TR 29x2.3"	Maxxis Rekon EXO 3C TR - 27.5x2.8"	Maxxis Rekon EXO 3C TR - 27.5x2.8"
Rear Tire	Maxxis Ardent Race EXO TR 29x2.35"	Maxxis Ardent Race EXO TR 29x2.35"	Maxxis Rekon EXO TR - 27.5x2.8"	Maxxis Rekon EXO TR - 27.5x2.8"
 Tubes/Sealant	Stan's Sealant	Stan's Sealant	Stan's Sealant	Stan's Sealant
Front Hub	DT 350 - 15x110mm, 28h	DT 350 - 15x110mm, 28h	DT 350 - 15x110mm, 28h	DT 350 - 15x110mm, 28h
Rear Hub	DT 350 - 12x148mm, 28h (XD)	DT 350 - 12x148mm, 28h (XD)	DT 350 - 12x148mm, 28h (XD)	DT 350 - 12x148mm, 28h (XD)
Rim	Race Face ARC 24 - 28h	Santa Cruz Reserve 27 Carbon - 28h	Race Face ARC 40 - 28h	ENVE M60 Forty Plus
Spokes	DT Competition	DT Competition Race	DT Competition	DT Competition Race
Prezzo telaio	€3.499,00	€3.499,00	€3.499,00	€3.499,00
Prezzo bici	€7.199,00	€8.599,00	€7.199,00	€9.799,00



JOPLIN C
XE 29

JOPLIN C
XE 27+

	JOPLIN C XE 29	JOPLIN C XE 27+
Frame	Carbon C 29/27+ 110mm Travel VPP™	Carbon C 29/27+ 110mm Travel VPP™
Shock	FOX Float Performance Elite DPS	FOX Float Performance Elite DPS
Fork	FOX 34 Float Performance Elite 120	FOX 34 Float Performance Elite 130
R. Derailleur	Shimano XT M8000	Shimano XT M8000
F. Derailleur	N/A	N/A
Chainguide	N/A	N/A
Shifters	Shimano XT M8000	Shimano XT M8000
Brakes	Shimano XT M8000	Shimano XT M8000
Rotors	Shimano RT86 Ice Tech - 180mm	Shimano RT86 Ice Tech - 180mm
Crankset	Race Face Turbine 30t - 170mm (S), 175mm (M-L)	Race Face Turbine 30t - 170mm (S), 175mm (M-L)
Cassette	E13 TRS Race 11 speed 9-46t	E13 TRS Race 11 speed 9-46t
Chain	Shimano SLX M7000	Shimano SLX M7000
Handlebar	Santa Cruz XC Carbon - 31.8 x 750mm	Santa Cruz XC Carbon - 31.8 x 750mm
Stem	Race Face Turbine Basic - 50mm	Race Face Turbine Basic - 50mm
Grips	Juliana grips - Coral	Juliana grips - Coral
Headset	Cane Creek 40 IS Integrated Headset	Cane Creek 40 IS Integrated Headset
Seatpost	RockShox Reverb Stealth 31.6x125mm (S), 150mm (M-L)	RockShox Reverb Stealth 31.6x125mm (S), 150mm (M-L)
Saddle	Juliana Primiero	Juliana Primiero
Front Tire	Maxxis Minion DHF 3C EXO TR 29x2.3"	Maxxis Rekon EXO 3C TR - 27.5x2.8"
Rear Tire	Maxxis Ardent Race EXO TR 29x2.35"	Maxxis Rekon EXO TR - 27.5x2.8"
 Tubes/Sealant	Stan's Sealant	Stan's Sealant
Front Hub	Novatec D641 - 15x110mm	Novatec D641 - 15x110mm
Rear Hub	Novatec D642 - 12x148mm (XD)	Novatec D642 - 12x148mm (XD)
Rim	Race Face AR 24 - 32h	Race Face AR 40 - 32h
Spokes	DT Competition	DT Competition
Prezzo bici	€5.999,00	€5.999,00



JOPLIN C
R 29

JOPLIN C
R 27+

JOPLIN C
S 29

JOPLIN C
S 27+

	JOPLIN C R 29	JOPLIN C R 27+	JOPLIN C S 29	JOPLIN C S 27+
Frame	Carbon C 29/27+ 110mm Travel VPP™	Carbon C 29/27+ 110mm Travel VPP™	Carbon C 29/27+ 110mm Travel VPP™	Carbon C 29/27+ 110mm Travel VPP™
Shock	FOX Float Performance DPS	FOX Float Performance DPS	FOX Float Performance DPS	FOX Float Performance DPS
Fork	FOX Rhythm 34 120	FOX Rhythm 34 130	FOX 34 Float Performance 120	FOX 34 Float Performance 130
R. Derailleur	SRAM NX 11 speed Long Cage	SRAM NX 11 speed Long Cage	SRAM GX Eagle 12 speed	SRAM GX Eagle 12 speed
F. Derailleur	N/A	N/A	N/A	N/A
Chainguide	N/A	N/A	N/A	N/A
Shifters	SRAM NX 11 speed	SRAM NX 11 speed	SRAM GX Eagle 12 speed	SRAM GX Eagle 12 speed
Brakes	SRAM Level T	SRAM Level T	SRAM Level TL	SRAM Level TL
Rotors	Avid Centerline - 180mm	Avid Centerline - 180mm	Avid Centerline - 180mm	Avid Centerline - 180mm
Crankset	Race Face Aeffect 30t - 170mm (S), 175mm (M-L)	Race Face Aeffect 30t - 170mm (S), 175mm (M-L)	SRAM GX Eagle 30t - 170mm (S), 175mm (M-L)	SRAM GX Eagle 30t - 170mm (S), 175mm (M-L)
Cassette	SRAM XG1150 CS 10-42t	SRAM XG1150 CS 10-42t	SRAM XG1275 Eagle 10-50t	SRAM XG1275 Eagle 10-50t
Chain	SRAM PC1110	SRAM PC1110	SRAM GX Eagle 12 speed	SRAM GX Eagle 12 speed
Handlebar	Race Face Ride Lo-Rise - 35x760mm	Race Face Ride Lo-Rise - 35x760mm	Race Face Ride Lo-Rise - 35x760mm	Race Face Ride Lo-Rise - 35x760mm
Stem	Race Face Ride - 50mm	Race Face Ride - 50mm	Race Face Aeffect R - 50mm	Race Face Aeffect R - 50mm
Grips	Juliana grips - Coral	Juliana grips - Coral	Juliana grips - Coral	Juliana grips - Coral
Headset	Cane Creek 10 IS Integrated Headset	Cane Creek 10 IS Integrated Headset	Cane Creek 40 IS Integrated Headset	Cane Creek 40 IS Integrated Headset
Seatpost	Race Face Aeffect - 31.6x125mm (S-M), 150mm (L)	Race Face Aeffect - 31.6x125mm (S-M), 150mm (L)	RockShox Reverb Stealth 31.6x125mm (S), 150mm (M-L)	RockShox Reverb Stealth 31.6x125mm (S), 150mm (M-L)
Saddle	Juliana Segundo	Juliana Segundo	Juliana Segundo	Juliana Segundo
Front Tire	Maxxis Minion DHF EXO TR - 29x2.3"	Maxxis Rekon EXO TR - 27.5x2.8"	Maxxis Minion DHF 3C EXO TR 29x2.3"	Maxxis Minion DHF 3C EXO TR 29x2.3"
Rear Tire	Maxxis Crossmark II DC EXO TR 29x2.25"	Maxxis Rekon EXO TR - 27.5x2.8"	Maxxis Ardent Race EXO TR 29x2.35"	Maxxis Ardent Race EXO TR 29x2.35"
 Tubes/Sealant	Stan's Sealant	Stan's Sealant	Stan's Sealant	Stan's Sealant
Front Hub	Novatec D711 - 15x110mm	Novatec D711 - 15x110mm	Novatec D641 - 15x110mm	Novatec D641 - 15x110mm
Rear Hub	Novatec D462 - 12x148mm (XD)	Novatec D462 - 12x148mm (XD)	Novatec D642 - 12x148mm (XD)	Novatec D642 - 12x148mm (XD)
Rim	WTB ST i23 TCS	Race Face AR 40 - 32h	Race Face AR 24 - 32h	Race Face AR 40 - 32h
Spokes	DT Competition	DT Competition	DT Competition	DT Competition
Prezzo bici	€4.499,00	€4.499,00	€5.199,00	€5.199,00

5010

Precisa, irriverente e agile sui single track affronta le curve con il massimo controllo e ama farsi strapazzare. La 5010 è il sogno di chi sa guidare in bici. Perfettamente a suo agio in missione backcountry con Steve Peat oppure con Danny MacAskill, la Santa Cruz 5010 con escursione da 130 mm sfoggia un carro corto e un movimento centrale basso per un carattere unico e un insaziabile desiderio di affrontare ripide salite tecniche. In discesa, l'angolo di sterzo di 67° e la combinazione reach generoso/attacco corto della bici si trasformano in un controllo preciso e totale.

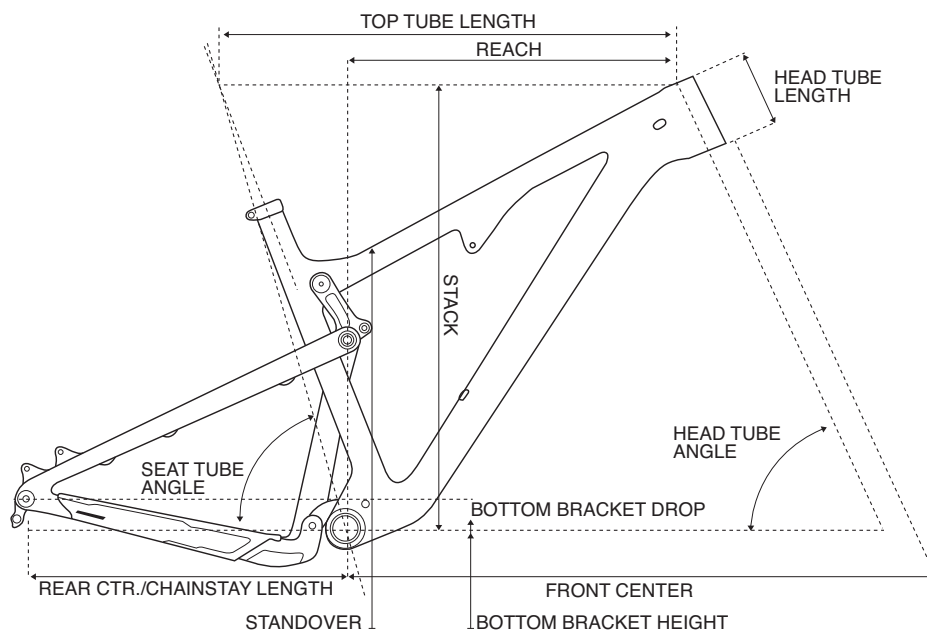

GEOMETRIA

	S	M	L	XL
Reach	405mm	425mm	445mm	475mm
Stack	586mm	595mm	604mm	613mm
Head Tube Angle	67°	67°	67°	67°
Head Tube Length	100mm	110mm	120mm	130mm
Seat Tube Angle	73.8°	73.8°	73.8°	73.8°
Seat Tube Length	395mm	420mm	460mm	495mm
Rear Center	426mm	426mm	426mm	426mm
Front Center	691mm	715mm	739mm	771mm
BB Height	334mm	334mm	334mm	334mm
BB Drop	20mm	20mm	20mm	20mm
Top Tube Length	576mm	598mm	621mm	654mm
Standover	711mm	717mm	719mm	732mm

CARATTERISTICHE

- 130 mm di escursione VPP.
- Pneumatici da 27,5".
- Opzione cerchi Santa Cruz Reserve 27 in carbonio sulle bici CC.
- Disponibile in carbonio CC, carbonio C e alluminio.
- Garanzia a vita per telaio e cuscinetti.
- Perfetta per: endurance trail, esplorazione backcountry.
- A suo agio su: terreni da fluidi a moderatamente aggressivi.
- Taglie: S, M, L, XL.
- Peso: Da 12,12 a 14,55 kg.
- Solo telaio/ammortizzatore a partire da: 2,63 kg.
- Colore: Gloss Siracha/Black - Gloss Ink/Black.



5010 CC
X01 27.55010 CC
X01 27.5 RESERVE5010 CC
XX1 27.55010 CC
XX1 27.5 RESERVE

	5010 CC X01 27.5	5010 CC X01 27.5 RESERVE	5010 CC XX1 27.5	5010 CC XX1 27.5 RESERVE
Frame	Carbon CC 27.5" 130mm Travel VPP™	Carbon CC 27.5" 130mm Travel VPP™	Carbon CC 27.5" 130mm Travel VPP™	Carbon CC 27.5" 130mm Travel VPP™
Shock	FOX Float Performance Elite DPS	FOX Float Performance Elite DPS	FOX Float Factory DPS Kashima	FOX Float Factory DPS Kashima
Fork	FOX 34 Float Performance Elite 130	FOX 34 Float Performance Elite 130	FOX 34 Float Factory 130 Kashima	FOX 34 Float Factory 130 Kashima
R. Derailleur	SRAM X01 Eagle 12 speed	SRAM X01 Eagle 12 speed	SRAM XX1 Eagle 12 speed	SRAM XX1 Eagle 12 speed
F. Derailleur	N/A	N/A	N/A	N/A
Chainguide	N/A	N/A	N/A	N/A
Shifters	SRAM X01 Eagle	SRAM X01 Eagle	SRAM XX1 Eagle 12 speed	SRAM XX1 Eagle 12 speed
Brakes	SRAM Guide RSC	SRAM Guide RSC	SRAM Guide Ultimate	SRAM Guide Ultimate
Rotors	Avid Centerline - 180mm	Avid Centerline - 180mm	Avid Centerline - 180mm	Avid Centerline - 180mm
Crankset	SRAM X1 Eagle Carbon 32t 170mm (S), 175mm (M-XL)	SRAM X1 Eagle Carbon 32t 170mm (S), 175mm (M-XL)	SRAM XX1 Eagle 32t 170mm (S), 175mm (M-XL)	SRAM XX1 Eagle 32t 170mm (S), 175mm (M-XL)
Cassette	SRAM XG1295 Eagle 10-50t	SRAM XG1295 Eagle 10-50t	SRAM XG1295 Eagle 10-50t	SRAM XG1295 Eagle 10-50t
Chain	SRAM X01 Eagle 12 speed	SRAM X01 Eagle 12 speed	SRAM XX1 Eagle 12 speed	SRAM XX1 Eagle 12 speed
Handlebar	Santa Cruz AM Carbon Bar 35x760mm (S-M), 800mm (L-XL)	Santa Cruz AM Carbon Bar 35x760mm (S-M), 800mm (L-XL)	Santa Cruz AM Carbon Bar - 35x760mm (S-M), 800mm (L-XL)	Santa Cruz AM Carbon Bar 35x760mm (S-M), 800mm (L-XL)
Stem	Race Face Aeffect R - 50mm	Race Face Aeffect R - 50mm	Race Face Turbine R - 50mm	Race Face Turbine R - 50mm
Grips	Santa Cruz Palmdale Grips - Black	Santa Cruz Palmdale Grips - Black	Santa Cruz Palmdale Grips - Black	Santa Cruz Palmdale Grips - Black
Headset	Cane Creek 40 ZS Headset	Cane Creek 40 ZS Headset	Cane Creek 110 ZS Headset	Cane Creek 110 ZS Headset
Seatpost	RockShox Reverb Stealth - 31.6x125mm (S), 150mm (M-L), 170mm (XL)	RockShox Reverb Stealth - 31.6x125mm (S), 150mm (M-L), 170mm (XL)	RockShox Reverb Stealth - 31.6x125mm (S), 150mm (M-L), 170mm (XL)	RockShox Reverb Stealth - 31.6x125mm (S), 150mm (M-L), 170mm (XL)
Saddle	WTB Silverado Pro	WTB Silverado Pro	WTB Silverado SLT	WTB Silverado SLT
Front Tire	Maxxis Minion DHF 3C EXO TR 27.5x2.3"	Maxxis Minion DHF 3C EXO TR 27.5x2.3"	Maxxis Minion DHF 3C EXO TR 27.5x2.3"	Maxxis Minion DHF 3C EXO TR 27.5x2.3"
Rear Tire	Maxxis Ardent Race TR 3C EXO 27.5x2.35"	Maxxis Ardent Race TR 3C EXO 27.5x2.35"	Maxxis Ardent Race TR 3C EXO 27.5x2.35"	Maxxis Ardent Race TR 3C EXO 27.5x2.35"
 Tubes/Sealant	Stan's Sealant	Stan's Sealant	Stan's Sealant	Stan's Sealant
Front Hub	DT 350 - 15x110mm, 28h	DT 350 - 15x110mm, 28h	i9 Torch Classic - 15x110mm, 28h	i9 Torch Classic - 15x110mm, 28h
Rear Hub	DT 350 - 12x148mm, 28h (XD)	DT 350 - 12x148mm, 28h (XD)	i9 Torch Classic - 12x148mm, 28h (XD)	i9 Torch Classic - 12x148mm, 28h (XD)
Rim	Race Face ARC 27 - 28h	Santa Cruz Reserve 27 Carbon - 28h	Race Face ARC 27 - 28h	Santa Cruz Reserve 27 Carbon - 28h
Spokes	DT Competition	DT Competition Race	DT Competition	DT Competition Race
Prezzo telaio	€3.499,00	€3.499,00	€3.499,00	€3.499,00
Prezzo bici	€7.199,00	€8.599,00	€8.699,00	€9.999,00

**5010 C
R 27.5**
**5010 C
S 27.5**
**5010 C
XE 27.5**

	5010 C R 27.5	5010 C S 27.5	5010 C XE 27.5
Frame	Carbon C 27.5" 130mm Travel VPP™	Carbon C 27.5" 130mm Travel VPP™	Carbon C 27.5" 130mm Travel VPP™
Shock	FOX Float Performance DPS	FOX Float Performance DPS	FOX Float Performance Elite DPX
Fork	FOX Rhythm 34 130	FOX 34 Float Performance 130	FOX 34 Float Performance Elite 130
R. Derailleur	SRAM NX 11 speed Long Cage	SRAM GX Eagle 12 speed	Shimano XT M8000
F. Derailleur	N/A	N/A	N/A
Chainguide	N/A	N/A	N/A
Shifters	SRAM NX 11 speed	SRAM GX Eagle 12 speed	Shimano XT M8000
Brakes	SRAM Level T	SRAM Guide R	Shimano XT M8000
Rotors	Avid Centerline - 180mm	Avid Centerline - 180mm	Shimano RT86 Ice Tech - 180mm
Crankset	Race Face Aeffect 32t 170mm (S), 175mm (M-XL)	SRAM GX Eagle 32t 170mm (S), 175mm (M-XL)	Race Face Turbine 30t 170mm (S), 175mm (M-XL)
Cassette	SRAM XG1150 CS 10-42t	SRAM XG1275 Eagle 10-50t	E13 TRS Race 11 speed 9-46t
Chain	SRAM PC1110	SRAM GX Eagle 12 speed	Shimano SLX M7000
Handlebar	Race Face Ride - 35x760mm	Race Face Ride - 35x760mm	Santa Cruz AM Carbon Bar - 35x760mm (S-M), 800mm (L-XL)
Stem	Race Face Ride - 50mm	Race Face Aeffect R - 50mm	Race Face Aeffect R - 50mm
Grips	Santa Cruz Palmdale Grips - Black	Santa Cruz Palmdale Grips - Black	Santa Cruz Palmdale Grips - Black
Headset	Cane Creek 10 ZS Headset	Cane Creek 40 ZS Headset	Cane Creek 40 ZS Headset
Seatpost	Race Face Aeffect 31.6x125mm (S-M), 150mm (L-XL)	RockShox Reverb Stealth - 31.6x125mm (S), 150mm (M-L), 170mm (XL)	RockShox Reverb Stealth - 31.6x125mm (S), 150mm (M-L), 170mm (XL)
Saddle	WTB Volt Race	WTB Volt Race	WTB Silverado Pro
Front Tire	Maxxis Minion DHF EXO TR 27.5x2.3"	Maxxis Minion DHF 3C EXO TR 27.5x2.3"	Maxxis Minion DHF 3C EXO TR 27.5x2.3"
Rear Tire	Maxxis Crossmark II EXO TR 27.5x2.25"	Maxxis Ardent Race TR 3C EXO 27.5x2.35"	Maxxis Ardent Race TR 3C EXO 27.5x2.35"
 Tubes/Sealant	Stan's Sealant	Stan's Sealant	Stan's Sealant
Front Hub	Novatec D711 - 15x110mm	Novatec D641 - 15x110mm	Novatec D641 - 15x110mm
Rear Hub	Novatec D462 - 12x148mm (XD)	Novatec D642 - 12x148mm (XD)	Novatec D642 - 12x148mm (XD)
Rim	WTB ST i25 TCS	Race Face AR 27 - 32h	Race Face AR 27 - 32h
Spokes	DT Competition	DT Competition	DT Competition
Prezzo bici	€4.499,00	€5.199,00	€5.999,00

5010 A
D 27.55010 A
R 27.55010 A
S 27.5

	5010 A D 27.5	5010 A R 27.5	5010 A S 27.5
Frame	Aluminum 27.5" 130mm Travel VPP™	Carbon C 27.5" 130mm Travel VPP™	Aluminum 27.5" 130mm Travel VPP™
Shock	FOX Float Performance DPS	FOX Float Performance DPS	FOX Float Performance DPS
Fork	RockShox Recon RL 130	FOX Rhythm 34 130	FOX 34 Float Performance 130
R. Derailleur	SRAM NX 11 speed Long Cage	SRAM NX 11 speed Long Cage	SRAM GX Eagle 12 speed
F. Derailleur	N/A	N/A	N/A
Chainguide	N/A	N/A	N/A
Shifters	SRAM NX 11 speed	SRAM NX 11 speed	SRAM GX Eagle 12 speed
Brakes	SRAM Level	SRAM Level T	SRAM Guide R
Rotors	Avid Centerline - 180mm	Avid Centerline - 180mm	Avid Centerline - 180mm
Crankset	Race Face Aeffect 32t 170mm (S), 175mm (M-XL)	Race Face Aeffect 32t 170mm (S), 175mm (M-XL)	SRAM GX Eagle 32t 170mm (S), 175mm (M-XL)
Cassette	SRAM PG1130 11-42t	SRAM XG1150 CS 10-42t	SRAM XG1275 Eagle 10-50t
Chain	SRAM PC1110	SRAM PC1110	SRAM GX Eagle 12 speed
Handlebar	Race Face Ride - 35x760mm	Race Face Ride - 35x760mm	Race Face Ride - 35x760mm
Stem	Race Face Ride - 50mm	Race Face Ride - 50mm	Race Face Aeffect R - 50mm
Grips	Santa Cruz Palmdale Grips - Black	Santa Cruz Palmdale Grips - Black	Santa Cruz Palmdale Grips - Black
Headset	Cane Creek 10 IS Integrated Headset	Cane Creek 10 IS Integrated Headset	Cane Creek 40 IS Integrated Headset
Seatpost	Race Face Ride	Race Face Aeffect - 31.6x125mm (S-M), 150mm (L-XL)	RockShox Reverb Stealth - 31.6x125mm (S), 150mm (M-L), 170mm (XL)
Saddle	WTB Volt Race	WTB Volt Race	WTB Volt Race
Front Tire	Maxxis Minion DHF EXO TR 27.5x2.3"	Maxxis Minion DHF 3C EXO TR 27.5x2.3"	Maxxis Minion DHF 3C EXO TR 27.5x2.3"
Rear Tire	Maxxis Crossmark II EXO TR 27.5x2.25"	Maxxis Crossmark II EXO TR 27.5x2.25"	Maxxis Ardent Race TR 3C EXO 27.5x2.35"
Tubes/Sealant	Stan's Sealant	Stan's Sealant	Stan's Sealant
Front Hub	Novatec D711 - 15x110mm	Novatec D641 - 15x110mm	Novatec D641 - 15x110mm
Rear Hub	Novatec D462 - 12x148mm (HG)	Novatec D642 - 12x148mm (XD)	Novatec D642 - 12x148mm (XD)
Rim	WTB ST i25 TCS	Race Face AR 27 - 32h	Race Face AR 27 - 32h
Spokes	DT Competition	DT Competition	DT Competition
Prezzo telaio	€2.299,00	€2.299,00	€2.299,00
Prezzo bici	€3.299,00	€3.899,00	€4.499,00

Juliana

FURTADO CC XX1 27.5



	FURTADO CC X01 27.5	FURTADO CC X01 27.5 RESERVE	FURTADO CC XX1 27.5	FURTADO CC XX1 27.5 RESERVE
Frame	Carbon CC 27.5" 130mm Travel VPP™	Carbon CC 27.5" 130mm Travel VPP™	Carbon CC 27.5" 130mm Travel VPP™	Carbon CC 27.5" 130mm Travel VPP™
Shock	FOX Float Performance Elite DPS	FOX Float Performance Elite DPS	FOX Float Performance Elite DPS	FOX Float Factory DPS Kashima
Fork	FOX 34 Float Performance Elite 130	FOX 34 Float Performance Elite 130	FOX 34 Float Performance Elite 130	FOX 34 Float Factory 130 Kashima
R. Derailleur	SRAM X01 Eagle 12 speed	SRAM X01 Eagle 12 speed	SRAM X01 Eagle 12 speed	SRAM XX1 Eagle 12 speed
F. Derailleur	N/A	N/A	N/A	N/A
Chainguide	N/A	N/A	N/A	N/A
Shifters	SRAM X01 Eagle	SRAM X01 Eagle	SRAM X01 Eagle	SRAM XX1 Eagle 12 speed
Brakes	SRAM Guide RSC	SRAM Guide RSC	SRAM Guide RSC	SRAM Guide Ultimate
Rotors	Avid Centerline - 180mm	Avid Centerline - 180mm	Avid Centerline - 180mm	Avid Centerline - 180mm
Crankset	SRAM X1 Eagle Carbon 32t 170mm (XS-S), 175mm (M-L)	SRAM X1 Eagle Carbon 32t 170mm (XS-S), 175mm (M-L)	SRAM X1 Eagle Carbon 32t 170mm (XS-S), 175mm (M-L)	SRAM XX1 Eagle 32t - 170mm (XS-S), 175mm (M-L)
Cassette	SRAM XG1295 Eagle 10-50t	SRAM XG1295 Eagle 10-50t	SRAM XG1295 Eagle 10-50t	SRAM XG1295 Eagle 10-50t
Chain	SRAM X01 Eagle 12 speed	SRAM X01 Eagle 12 speed	SRAM X01 Eagle 12 speed	SRAM XX1 Eagle 12 speed
Handlebar	Santa Cruz AM Carbon - 35x760mm	Santa Cruz AM Carbon - 35x760mm	Santa Cruz AM Carbon - 35x760mm	Santa Cruz AM Carbon - 35x760mm
Stem	Race Face Aeffect R - 50mm	Race Face Aeffect R - 50mm	Race Face Aeffect R - 50mm	Race Face Turbine R - 50mm
Grips	Juliana grips - Blue Raspberry	Juliana grips - Blue Raspberry	Juliana grips - Blue Raspberry	Juliana grips - Blue Raspberry
Headset	Cane Creek 40 ZS Headset	Cane Creek 40 ZS Headset	Cane Creek 40 ZS Headset	Cane Creek 110 ZS Headset
Seatpost	RockShox Reverb Stealth - 31.6x100mm (XS), 125mm (S), 150mm (M-L)	RockShox Reverb Stealth - 31.6x100mm (XS), 125mm (S), 150mm (M-L)	RockShox Reverb Stealth - 31.6x100mm (XS), 125mm (S), 150mm (M-L)	RockShox Reverb Stealth - 31.6x100mm (XS), 125mm (S), 150mm (M-L)
Saddle	Juliana Primiero	Juliana Primiero	Juliana Primiero	Juliana Carbon
Front Tire	Maxxis Minion DHF 3C EXO TR 27.5x2.3"	Maxxis Minion DHF 3C EXO TR 27.5x2.3"	Maxxis Minion DHF 3C EXO TR 27.5x2.3"	Maxxis Minion DHF 3C EXO TR 27.5x2.3"
Rear Tire	Maxxis Ardent Race TR 3C EXO 27.5x2.35"	Maxxis Ardent Race TR 3C EXO 27.5x2.35"	Maxxis Ardent Race TR 3C EXO 27.5x2.35"	Maxxis Ardent Race TR 3C EXO 27.5x2.35"
 Tubes/Sealant	Stan's Sealant	Stan's Sealant	Stan's Sealant	Stan's Sealant
Front Hub	DT 350 - 15x110mm, 28h	DT 350 - 15x110mm, 28h	DT 350 - 15x110mm, 28h	i9 Torch Classic - 15x110mm, 28h
Rear Hub	DT 350 - 12x148mm, 28h (XD)	DT 350 - 12x148mm, 28h (XD)	DT 350 - 12x148mm, 28h (XD)	i9 Torch Classic - 12x148mm, 28h (XD)
Rim	Race Face ARC 27 - 28h	Santa Cruz Reserve 27 Carbon - 28h	Race Face ARC 27 - 28h	Santa Cruz Reserve 27 Carbon - 28h
Spokes	DT Competition	DT Competition Race	DT Competition	DT Competition Race
Prezzo telaio	€3.499,00	€3.499,00	€3.499,00	€3.499,00
Prezzo bici	€7.199,00	€8.599,00	€8.699,00	€9.999,00



FURTADO C
R 27.5

FURTADO C
S 27.5

FURTADO C
XE 27.5

	FURTADO C R 27.5	FURTADO C S 27.5	FURTADO C XE 27.5
Frame	Carbon C 27.5" 130mm Travel VPP™	Carbon C 27.5" 130mm Travel VPP™	Carbon C 27.5" 130mm Travel VPP™
Shock	FOX Float Performance DPS	FOX Float Performance DPS	FOX Float Performance Elite DPX
Fork	FOX Rhythm 34 130	FOX 34 Float Performance 130	FOX 34 Float Performance Elite 130
R. Derailleur	SRAM NX 11 speed Long Cage	SRAM GX Eagle 12 speed	Shimano XT M8000
F. Derailleur	N/A	N/A	N/A
Chainguide	N/A	N/A	N/A
Shifters	SRAM NX 11 speed	SRAM GX Eagle 12 speed	Shimano XT M8000
Brakes	SRAM Level T	SRAM Guide R	Shimano XT M8000
Rotors	Avid Centerline - 180mm	Avid Centerline - 180mm	Shimano RT86 Ice Tech - 180mm
Crankset	Race Face Aeffect 30t 170mm (XS-S), 175mm (M-L)	SRAM GX Eagle 32t 170mm (XS-S), 175mm (M-L)	Race Face Turbine 30t 170mm (XS-S), 175mm (M-L)
Cassette	SRAM XG1150 CS 10-42t	SRAM XG1275 Eagle 10-50t	E13 TRS Race 11 speed 9-46t
Chain	SRAM PC1110	SRAM GX Eagle 12 speed	Shimano SLX M7000
Handlebar	Race Face Ride - 35x760mm	Race Face Ride - 35x760mm	Santa Cruz AM Carbon - 35x760mm
Stem	Race Face Ride - 50mm	Race Face Aeffect R - 50mm	Race Face Aeffect R - 50mm
Grips	Juliana grips - Blue Raspberry	Juliana grips - Blue Raspberry	Juliana grips - Blue Raspberry
Headset	Cane Creek 10 ZS Headset	Cane Creek 40 ZS Headset	Cane Creek 40 ZS Headset
Seatpost	Race Face Aeffect 31.6x125mm (XS-M), 150mm (L)	RockShox Reverb Stealth - 31.6x100mm (XS), 125mm (S), 150mm (M-L)	RockShox Reverb Stealth - 31.6x100mm (XS), 125mm (S), 150mm (M-L)
Saddle	Juliana Segundo	Juliana Segundo	Juliana Primiero
Front Tire	Maxxis Minion DHF EXO TR 27.5x2.3"	Maxxis Minion DHF 3C EXO TR 27.5x2.3"	Maxxis Minion DHF 3C EXO TR 27.5x2.3"
Rear Tire	Maxxis Crossmark II EXO TR 27.5x2.25"	Maxxis Ardent Race TR 3C EXO 27.5x2.35"	Maxxis Ardent Race TR 3C EXO 27.5x2.35"
 Tubes/Sealant	Stan's Sealant	Stan's Sealant	Stan's Sealant
Front Hub	Novatec D711 - 15x110mm	Novatec D641 - 15x110mm	Novatec D641 - 15x110mm
Rear Hub	Novatec D462 - 12x148mm (XD)	Novatec D642 - 12x148mm (XD)	Novatec D642 - 12x148mm (XD)
Rim	WTB ST i25 TCS	Race Face AR 27 - 32h	Race Face AR 27 - 32h
Spokes	DT Competition	DT Competition	DT Competition
Prezzo bici	€4.499,00	€5.199,00	€5.999,00

HIGHTOWER

La Hightower aggiunge versatilità e forza andando a collocare tra il trail riding aggressivo e l'enduro racing. Sfoggia 135 mm di escursione posteriore e consente di scegliere tra la velocità di una gomma da 29" (con forcella da 140 mm) e una presa maggiore con la 27,5+ (forcella da 150 mm). La Hightower offre quella confidenza che consente di mollare di più i freni e allo stesso tempo, affronta le curve alla grande. Come 29" è super veloce e con le gomme Plus è una Monster Truck assoluta. Eccezionale per la pedalata da seduti, comoda tutto il giorno.

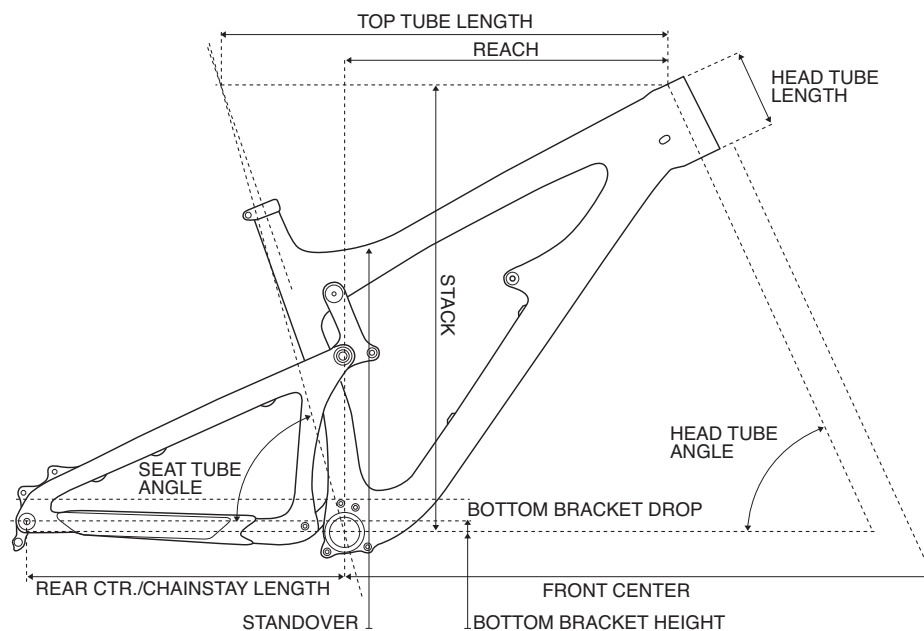

GEOMETRIA

	S (27.5+/29)	M (27.5+/29)	L (27.5+/29)	XL (27.5+/29)	XXL (27.5+/29)
Reach	403 / 405mm	428 / 430mm	448 / 450mm	473 / 475mm	503 / 505mm
Stack	606 / 604mm	610 / 604mm	615 / 613mm	624 / 623mm	643 / 641mm
Head Tube Angle	66.8 / 67°	66.8 / 67°	66.8 / 67°	66.8 / 67°	66.8 / 67°
Head Tube Length	90 / 90mm	90 / 90mm	100 / 100mm	110 / 110mm	130 / 130mm
Seat Tube Angle	74.1 / 74.3°	74.1 / 74.3°	74.1 / 74.3°	74.1 / 74.3°	74.1 / 74.3°
Seat Tube Length	390 / 390mm	420 / 420mm	450 / 450mm	490 / 490mm	510 / 510mm
Rear Center	434 / 435mm	434 / 435mm	434 / 435mm	434 / 435mm	434 / 435mm
Front Center	707 / 703mm	734 / 730mm	756 / 752mm	784 / 781mm	822 / 818mm
BB Height	335 / 337mm	335 / 337mm	335 / 337mm	335 / 337mm	335 / 337mm
BB Drop	27 / 33mm	27 / 33mm	27 / 33mm	27 / 33mm	27 / 33mm
Top Tube Length	575 / 574mm	602 / 601mm	623 / 622mm	651 / 650mm	689 / 685mm
Standover	707 / 710mm	707 / 710mm	710 / 713mm	717 / 720mm	725 / 727mm

CARATTERISTICHE

- 135 mm di escursione VPP.
- Pneumatici convertibili tra 29 e 27,5+.
- Opzione cerchi Santa Cruz Reserve 27 in carbonio sulle bici CC.
- Disponibile in carbonio CC e carbonio C.
- Perfetta per percorsi all-around fino ai sentieri più aggressivi.
- A suo agio su piste tecniche.
- Garanzia a vita per telaio e cuscinetti.
- Taglie: S, M, L, XL, XXL.
- Peso: 12,85-13,4 kg.
- Solo telaio/ammortizzatore: 2,67 kg.
- Colore: Cannery Gray/Blue - Gloss Mango/Orange.





	HIGHTOWER CC XX1 29	HIGHTOWER CC XX1 29 RESERVE	HIGHTOWER CC XX1 27+	HIGHTOWER CC XX1 27+ ENVE
Frame	Carbon CC 29/27+135mm Travel VPP™	Carbon CC 29/27+135mm Travel VPP™	Carbon CC 29/27+135mm Travel VPP™	Carbon CC 29/27+ 135mm Travel VPP™
Shock	FOX Float Factory DPS Kashima	FOX Float Factory DPS Kashima	FOX Float Factory DPS Kashima	FOX Float Factory DPS Kashima
Fork	FOX 36 F140 Factory Kashima	FOX 36 F140 Factory Kashima	FOX 36 F150 Factory Kashima	FOX 36 F150 Factory Kashima
R. Derailleur	SRAM XX1 Eagle 12 speed	SRAM XX1 Eagle 12 speed	SRAM XX1 Eagle 12 speed	SRAM XX1 Eagle 12 speed
F. Derailleur	N/A	N/A	N/A	N/A
Chainguide	N/A	N/A	N/A	N/A
Shifters	SRAM XX1 Eagle 12 speed	SRAM XX1 Eagle 12 speed	SRAM XX1 Eagle 12 speed	SRAM XX1 Eagle 12 speed
Brakes	SRAM Guide RSC	SRAM Guide Ultimate	SRAM Guide Ultimate	SRAM Guide Ultimate
Rotors	Avid Centerline - 180mm	Avid Centerline - 180mm	Avid Centerline - 180mm	Avid Centerline - 180mm
Crankset	SRAM XX1 Eagle 30t -170mm (S), 175mm (M-XXL)	SRAM XX1 Eagle 30t -170mm (S), 175mm (M-XXL)	SRAM XX1 Eagle 30t -170mm (S), 175mm (M-XXL)	SRAM XX1 Eagle 30t -170mm (S), 175mm (M-XXL)
Cassette	SRAM XG1295 Eagle 10-50t	SRAM XG1295 Eagle 10-50t	SRAM XG1295 Eagle 10-50t	SRAM XG1295 Eagle 10-50t
Chain	SRAM XX1 Eagle 12 speed	SRAM XX1 Eagle 12 speed	SRAM XX1 Eagle 12 speed	SRAM XX1 Eagle 12 speed
Handlebar	Santa Cruz AM Flat Bar Carbon 31.8 x 780mm	Santa Cruz AM Flat Bar Carbon 31.8 x 780mm	Santa Cruz AM Flat Bar Carbon 31.8 x 780mm	Santa Cruz AM Flat Bar Carbon 31.8 x 780mm
Stem	Easton Haven - 55mm	Easton Haven - 55mm	Easton Haven - 55mm	Easton Haven - 55mm
Grips	Santa Cruz Palmdale Grips - Black	Santa Cruz Palmdale Grips - Black	Santa Cruz Palmdale Grips - Black	Santa Cruz Palmdale Grips - Black
Headset	Cane Creek 110 IS Integrated Headset	Cane Creek 110 IS Integrated Headset	Cane Creek 110 IS Integrated Headset	Cane Creek 110 IS Integrated Headset
Seatpost	RockShox Reverb Stealth - 31.6x125mm (S), 150mm (M-L), 170mm (XL-XXL)	RockShox Reverb Stealth - 31.6x125mm (S), 150mm (M-L), 170mm (XL-XXL)	RockShox Reverb Stealth - 31.6x125mm (S), 150mm (M-L), 170mm (XL-XXL)	RockShox Reverb Stealth - 31.6x125mm (S), 150mm (M-L), 170mm (XL-XXL)
Saddle	WTB Silverado SLT	WTB Silverado SLT	WTB Silverado SLT	WTB Silverado SLT
Front Tire	Maxxis Minion DHF 3C EXO TR 29x2.3"	Maxxis Minion DHF 3C EXO TR 29x2.3"	Maxxis Rekon EXO 3C TR - 27.5x2.8"	Maxxis Rekon EXO 3C TR - 27.5x2.8"
Rear Tire	Maxxis Minion DHR2 EXO TR 29x2.3"	Maxxis Minion DHR2 EXO TR 29x2.3"	Maxxis Rekon EXO TR - 27.5x2.8"	Maxxis Rekon EXO TR - 27.5x2.8"
 Tubes/Sealant	Stan's Sealant	Stan's Sealant	Stan's Sealant	Stan's Sealant
Front Hub	i9 Torch Classic - 15x110mm, 28h	i9 Torch Classic - 15x110mm, 28h	i9 Torch Classic - 15x110mm, 28h	i9 Torch Classic - 15x110mm, 28h
Rear Hub	i9 Torch Classic - 12x148mm, 28h (XD)	i9 Torch Classic - 12x148mm, 28h (XD)	i9 Torch Classic - 12x148mm, 28h (XD)	i9 Torch Classic - 12x148mm, 28h (XD)
Rim	Race Face ARC 27 - 28h	Santa Cruz Reserve 27 Carbon - 28h	Race Face ARC 40 - 28h	ENVE M60 Forty Plus
Spokes	DT Competition	DT Competition Race	DT Competition	DT Competition Race
Prezzo telaio	€3.499,00	€3.499,00	€3.499,00	€3.499,00
Prezzo bici	€8.699,00	€9.999,00	€8.699,00	€10.999,00



	HIGHTOWER CC X01 29	HIGHTOWER CC X01 29 RESERVE	HIGHTOWER CC X01 27+	HIGHTOWER CC X01 27+ ENVE
Frame	Carbon CC 29/27+135mm Travel VPP™	Carbon CC 29/27+135mm Travel VPP™	Carbon CC 29/27+135mm Travel VPP™	Carbon CC 29/27+135mm Travel VPP™
Shock	FOX Float Performance Elite DPS	FOX Float Performance Elite DPS	FOX Float Performance Elite DPS	FOX Float Performance Elite DPS
Fork	FOX 36 F140 Performance Elite	FOX 36 F140 Performance Elite	FOX 36 Float Performance Elite 150	FOX 36 Float Performance Elite 150
R. Derailleur	SRAM X01 Eagle 12 speed	SRAM X01 Eagle 12 speed	SRAM X01 Eagle 12 speed	SRAM X01 Eagle 12 speed
F. Derailleur	N/A	N/A	N/A	N/A
Chainguide	N/A	N/A	N/A	N/A
Shifters	SRAM X01 Eagle	SRAM X01 Eagle	SRAM X01 Eagle	SRAM X01 Eagle
Brakes	SRAM Guide RSC	SRAM Guide RSC	SRAM Guide Ultimate	SRAM Guide Ultimate
Rotors	Avid Centerline - 180mm	Avid Centerline - 180mm	Avid Centerline - 180mm	Avid Centerline - 180mm
Crankset	SRAM XX1 Eagle 30t -170mm (S), 175mm (M-XXL)	SRAM XX1 Eagle 30t -170mm (S), 175mm (M-XXL)	SRAM XX1 Eagle Carbon 30t - 170mm (S), 175mm (M-XXL)	SRAM XX1 Eagle Carbon 30t - 170mm (S), 175mm (M-XXL)
Cassette	SRAM XG1295 Eagle 10-50t	SRAM XG1295 Eagle 10-50t	SRAM XG1295 Eagle 10-50t	SRAM XG1295 Eagle 10-50t
Chain	SRAM X01 Eagle 12 speed	SRAM X01 Eagle 12 speed	SRAM X01 Eagle 12 speed	SRAM X01 Eagle 12 speed
Handlebar	Santa Cruz AM Flat Bar Carbon 31.8 x 780mm	Santa Cruz AM Flat Bar Carbon 31.8 x 780mm	Santa Cruz AM Flat Bar Carbon 31.8 x 780mm	Santa Cruz AM Flat Bar Carbon 31.8 x 780mm
Stem	Easton Haven - 55mm	Easton Haven - 55mm	Easton Haven - 55mm	Easton Haven - 55mm
Grips	Santa Cruz Palmdale Grips - Black	Santa Cruz Palmdale Grips - Black	Santa Cruz Palmdale Grips - Black	Santa Cruz Palmdale Grips - Black
Headset	Cane Creek 40 IS Integrated Headset	Cane Creek 40 IS Integrated Headset	Cane Creek 40 IS Integrated Headset	Cane Creek 40 IS Integrated Headset
Seatpost	RockShox Reverb Stealth - 31.6x125mm (S), 150mm (M-L), 170mm (XL-XXL)	RockShox Reverb Stealth - 31.6x125mm (S), 150mm (M-L), 170mm (XL-XXL)	RockShox Reverb Stealth - 31.6x125mm (S), 150mm (M-L), 170mm (XL-XXL)	RockShox Reverb Stealth - 31.6x125mm (S), 150mm (M-L), 170mm (XL-XXL)
Saddle	WTB Silverado Pro	WTB Silverado Pro	WTB Silverado Pro	WTB Silverado Pro
Front Tire	Maxxis Minion DHF 3C EXO TR 29x2.3"	Maxxis Minion DHF 3C EXO TR 29x2.3"	Maxxis Rekon EXO 3C TR - 27.5x2.8"	Maxxis Rekon EXO 3C TR - 27.5x2.8"
Rear Tire	Maxxis Minion DHR2 EXO TR 29x2.3"	Maxxis Minion DHR2 EXO TR 29x2.3"	Maxxis Rekon EXO TR - 27.5x2.8"	Maxxis Rekon EXO TR - 27.5x2.8"
 Tubes/Sealant	Stan's Sealant	Stan's Sealant	Stan's Sealant	Stan's Sealant
Front Hub	DT 350 - 15x110mm, 28h	DT 350 - 15x110mm, 28h	DT 350 - 15x110mm, 28h	DT 350 - 15x110mm, 28h
Rear Hub	DT 350 - 12x148mm, 28h (XD)	DT 350 - 12x148mm, 28h (XD)	DT 350 - 12x148mm, 28h (XD)	DT 350 - 12x148mm, 28h (XD)
Rim	Race Face ARC 27 - 28h	Santa Cruz Reserve 27 Carbon - 28h	Race Face ARC 40 - 28h	ENVE M60 Forty Plus
Spokes	DT Competition	DT Competition Race	DT Competition	DT Competition Race
Prezzo telaio	€3.499,00	€3.499,00	€3.499,00	€3.499,00
Prezzo bici	€7.399,00	€8.599,00	€7.399,00	€9.999,00



HIGHTOWER C XE 29

HIGHTOWER C XE 27+

Frame	Carbon C 29/27+ 135mm Travel VPP™	Carbon C 29/27+ 135mm Travel VPP™
Shock	FOX Float Performance Elite DPS	FOX Float Performance Elite DPS
Fork	FOX 36 F140 Performance Elite	FOX 36 Float Performance Elite 150
R. Derailleur	Shimano XT M8000	Shimano XT M8000
F. Derailleur	N/A	N/A
Chainguide	N/A	N/A
Shifters	Shimano XT M8000	Shimano XT M8000
Brakes	Shimano XT M8000	Shimano XT M8000
Rotors	Shimano RT86 Ice Tech - 180mm	Shimano RT86 Ice Tech - 180mm
Crankset	Race Face Turbine 30t - 170mm (S), 175mm (M-XXL)	Race Face Turbine 30t - 170mm (S), 175mm (M-XXL)
Cassette	E13 TRS Race 11 speed 9-46t	E13 TRS Race 11 speed 9-46t
Chain	Shimano SLX M7000	Shimano SLX M7000
Handlebar	Santa Cruz AM Flat Bar Carbon 31.8 x 780mm	Santa Cruz AM Flat Bar Carbon 31.8 x 780mm
Stem	Race Face Turbine Basic - 50mm	Race Face Turbine Basic - 50mm
Grips	Santa Cruz Palmdale Grips - Black	Santa Cruz Palmdale Grips - Black
Headset	Cane Creek 40 IS Integrated Headset	Cane Creek 40 IS Integrated Headset
Seatpost	RockShox Reverb Stealth - 31.6x125mm (S), 150mm (M-L), 170mm (XL-XXL)	RockShox Reverb Stealth - 31.6x125mm (S), 150mm (M-L), 170mm (XL-XXL)
Saddle	WTB Silverado Pro	WTB Silverado Pro
Front Tire	Maxxis Minion DHF 3C EXO TR 29x2.3"	Maxxis Rekon EXO 3C TR - 27.5x2.8"
Rear Tire	Maxxis Minion DHR2 EXO TR 29x2.3"	Maxxis Rekon EXO TR - 27.5x2.8"
Tubes/Sealant	Stan's Sealant	Stan's Sealant
Front Hub	Novatec D641 - 15x110mm	Novatec D641 - 15x110mm
Rear Hub	Novatec D642 - 12x148mm (XD)	Novatec D642 - 12x148mm (XD)
Rim	Race Face AR 27 - 32h	Race Face AR 40 - 32h
Spokes	DT Competition	DT Competition
Prezzo bici	€ 5.999,00	€ 5.999,00



HIGHTOWER C
R 29

HIGHTOWER C
R 27+

HIGHTOWER C
S 29

HIGHTOWER C
S 27+

	HIGHTOWER C R 29	HIGHTOWER C R 27+	HIGHTOWER C S 29	HIGHTOWER C S 27+
Frame	Carbon C 29/27+ 135mm Travel VPP™	Carbon C 29/27+ 135mm Travel VPP™	Carbon C 29/27+ 135mm Travel VPP™	Carbon C 29/27+ 135mm Travel VPP™
Shock	FOX Float Performance DPS	FOX Float Performance DPS	FOX Float Performance DPS	FOX Float Performance DPS
Fork	RockShox Revelation RC 140	RockShox Revelation RC 150	FOX 36 F140 Performance	FOX 36 F150 Performance
R. Derailleur	SRAM NX 11 speed Long Cage	SRAM NX 11 speed Long Cage	SRAM GX Eagle 12 speed	SRAM GX Eagle 12 speed
F. Derailleur	N/A	N/A	N/A	N/A
Chainguide	N/A	N/A	N/A	N/A
Shifters	SRAM NX 11 speed	SRAM NX 11 speed	SRAM GX Eagle 12 speed	SRAM GX Eagle 12 speed
Brakes	SRAM Level T	SRAM Level T	SRAM Guide R	SRAM Guide R
Rotors	Avid Centerline - 180mm	Avid Centerline - 180mm	Avid Centerline - 180mm	Avid Centerline - 180mm
Crankset	Race Face Aeffect 30t - 170mm (S), 175mm (M-XXL)	Race Face Aeffect 30t - 170mm (S), 175mm (M-XXL)	SRAM GX Eagle 30t - 170mm (S), 175mm (M-XXL)	SRAM GX Eagle 30t - 170mm (S), 175mm (M-XXL)
Cassette	SRAM XG1150 CS 10-42t	SRAM XG1150 CS 10-42t	SRAM XG1275 Eagle 10-50t	SRAM XG1275 Eagle 10-50t
Chain	SRAM PC1110	SRAM PC1110	SRAM GX Eagle 12 speed	SRAM GX Eagle 12 speed
Handlebar	Race Face Aeffect R - 35x780mm, 20mm Rise	Race Face Aeffect R - 35x780mm, 20mm Rise	Race Face Aeffect R - 35x780mm, 20mm Rise	Race Face Aeffect R - 35x780mm, 20mm Rise
Stem	Race Face Ride - 50mm	Race Face Ride - 50mm	Race Face Aeffect R - 50mm	Race Face Aeffect R - 50mm
Grips	Santa Cruz Palmdale Grips - Black	Santa Cruz Palmdale Grips - Black	Santa Cruz Palmdale Grips - Black	Santa Cruz Palmdale Grips - Black
Headset	Cane Creek 10 IS Integrated Headset	Cane Creek 10 IS Integrated Headset	Cane Creek 40 IS Integrated Headset	Cane Creek 40 IS Integrated Headset
Seatpost	Race Face Aeffect - 31.6x125mm (S-M), 150mm (L-XXL)	Race Face Aeffect - 31.6x125mm (S-M), 150mm (L-XXL)	RockShox Reverb Stealth - 31.6x125mm (S), 150mm (M-L), 170mm (XL-XXL)	RockShox Reverb Stealth - 31.6x125mm (S), 150mm (M-L), 170mm (XL-XXL)
Saddle	WTB Volt Race	WTB Volt Race	WTB Volt Race	WTB Volt Race
Front Tire	Maxxis Minion DHF EXO TR - 29x2.3"	Maxxis Rekon EXO TR - 27.5x2.8"	Maxxis Minion DHF 3C EXO TR 29x2.3"	Maxxis Rekon EXO 3C TR - 27.5x2.8"
Rear Tire	Maxxis Minion DHR2 EXO TR 29x2.3"	Maxxis Rekon EXO TR - 27.5x2.8"	Maxxis Minion DHR2 EXO TR 29x2.3"	Maxxis Rekon EXO TR - 27.5x2.8"
 Tubes/Sealant	Stan's Sealant	Stan's Sealant	Stan's Sealant	Stan's Sealant
Front Hub	Novatec D711 - 15x110mm	Novatec D711 - 15x110mm	Novatec D641 - 15x110mm	Novatec D641 - 15x110mm
Rear Hub	Novatec D462 - 12x148mm (XD)	Novatec D462 - 12x148mm (XD)	Novatec D642 - 12x148mm (XD)	Novatec D642 - 12x148mm (XD)
Rim	WTB ST i25 TCS	Race Face AR 40 - 32h	Race Face AR 27 - 32h	Race Face AR 40 - 32h
Spokes	DT Competition	DT Competition	DT Competition	DT Competition
Prezzo bici	€4.599,00	€4.599,00	€5.299,00	€5.299,00



HIGHTOWER LT

L'ultima arrivata è anche la più desiderata, oggi, se sei un biker che fa gare di enduro oppure se ti piacciono le sfide sui single track più difficili.

Ruote da 29", 150 mm di corsa al posteriore, sospensione Vpp e una geometria disegnata per essere cattivo. Se hai cattiveria nel tuo stile di guida.

Con le ruote Santa Cruz Reserve diventa una lama, solida e leggera, e per lei gli standard di Mtb da enduro non esistono più.

È lei la regina sulle Speciali ed è lei la più veloce se hai quel pizzico di cattiveria nelle mani...

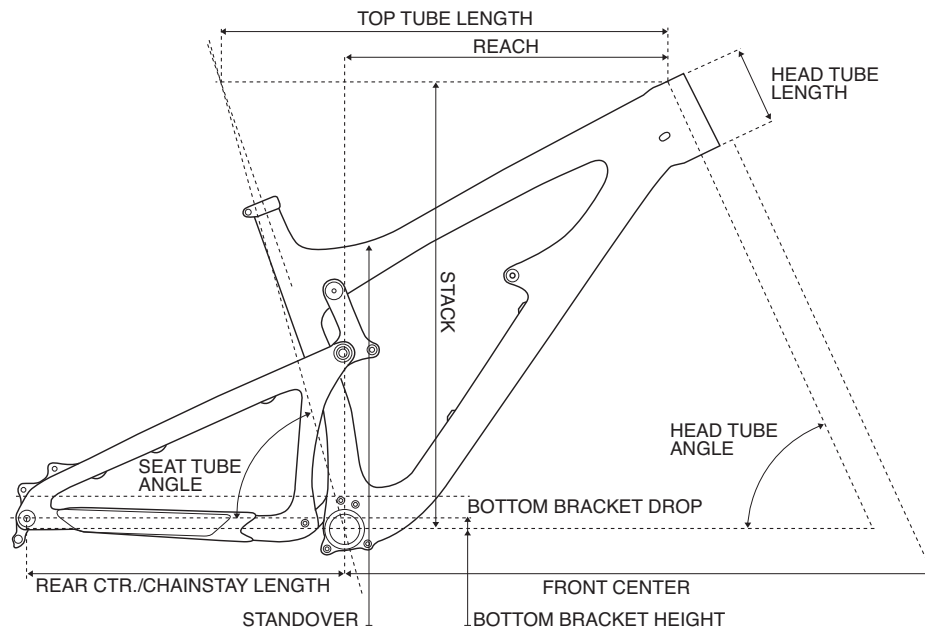

GEOMETRIA

	S	M	L	XL	XXL
Reach	398mm	423mm	443mm	468mm	498mm
Stack	609mm	614mm	618mm	628mm	646mm
Head Tube Angle	66.4°	66.4°	66.4°	66.4°	66.4°
Head Tube Length	90mm	95mm	100mm	110mm	130mm
Seat Tube Angle	73.7°	73.7°	73.7°	73.7°	73.7°
Seat Tube Length	390mm	420mm	450mm	490mm	510mm
Rear Center	438mm	438mm	438mm	438mm	438mm
Front Center	706mm	733mm	755mm	784mm	822mm
BB Height	338mm	338mm	338mm	338mm	338mm
BB Drop	32mm	32mm	32mm	32mm	32mm
Top Tube Length	577mm	605mm	626mm	653mm	692mm
Standover	710mm	710mm	713mm	720mm	727mm

CARATTERISTICHE

- 150 mm di escursione VPP.
- Ruote da 29".
- Opzione cerchi Santa Cruz Reserve 30 in carbonio sulle bici CC.
- Disponibile in carbonio CC e carbonio C.
- Garanzia a vita per telaio e cuscinetti.
- Perfetta per: competizioni enduro, percorsi aggressivi.
- A suo agio su: percorsi ad alta velocità, rocciosi, con radici, tecnici.
- Taglie: S, M, L, XL, XXL.
- Peso: 12,85-13,4 kg.
- Solo telaio/ammortizzatore: 2,67 kg.
- Colore: Gloss Slate/White - Gloss Wicklow Green/Black.





HIGHTOWER LT CC
X01 29

HIGHTOWER LT CC
X01 29 RESERVE

HIGHTOWER LT CC
XX1 29

HIGHTOWER LT CC
XX1 29 RESERVE

	HIGHTOWER LT CC X01 29	HIGHTOWER LT CC X01 29 RESERVE	HIGHTOWER LT CC XX1 29	HIGHTOWER LT CC XX1 29 RESERVE
Frame	Carbon CC 29" 150mm Travel VPP™	Carbon CC 29" 150mm Travel VPP™	Carbon CC 29" 150mm Travel VPP™	Carbon CC 29" 150mm Travel VPP™
Shock	FOX Float Performance Elite DPX2	FOX Float Performance Elite DPX2	FOX Float Factory DPX2 Kashima	FOX Float Factory DPX2 Kashima
Fork	FOX 36 Float Performance Elite 150	FOX 36 Float Performance Elite 150	FOX 36 F150 Factory Kashima	FOX 36 F150 Factory Kashima
R. Derailleur	SRAM X01 Eagle 12 speed	SRAM X01 Eagle 12 speed	SRAM XX1 Eagle 12 speed	SRAM XX1 Eagle 12 speed
F. Derailleur	N/A	N/A	N/A	N/A
Chainguide	N/A	N/A	N/A	N/A
Shifters	SRAM X01 Eagle	SRAM X01 Eagle	SRAM XX1 Eagle 12 speed	SRAM XX1 Eagle 12 speed
Brakes	SRAM Guide RSC	SRAM Guide RSC	SRAM Guide Ultimate	SRAM Guide Ultimate
Rotors	Avid Centerline - 180mm	Avid Centerline - 180mm	Avid Centerline - 180mm	Avid Centerline - 180mm
Crankset	SRAM X1 Eagle Carbon 30t - 170mm (S), 175mm (M-XXL)	SRAM X1 Eagle Carbon 30t - 170mm (S), 175mm (M-XXL)	SRAM XX1 Eagle 30t -170mm (S), 175mm (M-XXL)	SRAM XX1 Eagle 30t -170mm (S), 175mm (M-XXL)
Cassette	SRAM XG1295 Eagle 10-50t	SRAM XG1295 Eagle 10-50t	SRAM XG1295 Eagle 10-50t	SRAM XG1295 Eagle 10-50t
Chain	SRAM X01 Eagle 12 speed	SRAM X01 Eagle 12 speed	SRAM XX1 Eagle 12 speed	SRAM XX1 Eagle 12 speed
Handlebar	Santa Cruz AM Carbon Bar - 35x800mm	Santa Cruz AM Carbon Bar - 35x800mm	Santa Cruz AM Carbon Bar - 35x800mm	Santa Cruz AM Carbon Bar - 35x800mm
Stem	Race Face Aeffect R - 50mm	Race Face Aeffect R - 50mm	Race Face Turbine R - 50mm	Race Face Turbine R - 50mm
Grips	Santa Cruz Palmdale Grips - Black	Santa Cruz Palmdale Grips - Black	Santa Cruz Palmdale Grips - Black	Santa Cruz Palmdale Grips - Black
Headset	Cane Creek 40 IS Integrated Headset	Cane Creek 40 IS Integrated Headset	Cane Creek 110 IS Integrated Headset	Cane Creek 110 IS Integrated Headset
Seatpost	RockShox Reverb Stealth - 31.6x125mm (S), 150mm (M-L), 170mm (XL-XXL)	RockShox Reverb Stealth - 31.6x125mm (S), 150mm (M-L), 170mm (XL-XXL)	RockShox Reverb Stealth - 31.6x125mm (S), 150mm (M-L), 170mm (XL-XXL)	RockShox Reverb Stealth - 31.6x125mm (S), 150mm (M-L), 170mm (XL-XXL)
Saddle	WTB Silverado Pro	WTB Silverado Pro	WTB Silverado SLT	WTB Silverado SLT
Front Tire	Maxxis Minion DHR 3C EXO TR 29x2.4"	Maxxis Minion DHR 3C EXO TR 29x2.4"	Maxxis Minion DHR 3C EXO TR 29x2.4"	Maxxis Minion DHR 3C EXO TR 29x2.4"
Rear Tire	Maxxis Minion DHR 3C EXO TR 29x2.4"	Maxxis Minion DHR 3C EXO TR 29x2.4"	Maxxis Minion DHR 3C EXO TR 29x2.4"	Maxxis Minion DHR 3C EXO TR 29x2.4"
 Tubes/Sealant	Stan's Sealant	Stan's Sealant	Stan's Sealant	Stan's Sealant
Front Hub	DT 350 - 15x110mm, 28h	DT 350 - 15x110mm, 28h	i9 Torch Classic - 15x110mm, 28h	i9 Torch Classic - 15x110mm, 28h
Rear Hub	DT 350 - 12x148mm, 28h (XD)	DT 350 - 12x148mm, 28h (XD)	i9 Torch Classic - 12x148mm, 28h (XD)	i9 Torch Classic - 12x148mm, 28h (XD)
Rim	E13 TRS Race 30mm - 32h	Santa Cruz Reserve 30 Carbon - 28h	E13 TRS + 30mm - 32h	Santa Cruz Reserve 30 Carbon - 28h
Spokes	DT Competition	DT Competition Race	DT Competition	DT Competition Race
Prezzo telaio	€3.599,00	€3.599,00	€3.599,00	€3.599,00
Prezzo bici	€7.499,00	€8.899,00	€8.699,00	€9.999,00



HIGHTOWER LT C
R 29

HIGHTOWER LT C
S 29

HIGHTOWER LT C
XE 29

	HIGHTOWER LT C R 29	HIGHTOWER LT C S 29	HIGHTOWER LT C XE 29
Frame	Carbon C 29" 150mm Travel VPP™	Carbon C 29" 150mm Travel VPP™	Carbon C 29" 150mm Travel VPP™
Shock	FOX Float Performance DPS	FOX Float Performance DPS	FOX Float Performance Elite DPX2
Fork	RockShox Revelation RC 150	FOX 36 F150 Performance	FOX 36 Float Performance Elite 150
R. Derailleur	SRAM NX 11 speed Long Cage	SRAM GX Eagle 12 speed	Shimano XT M8000
F. Derailleur	N/A	N/A	N/A
Chainguide	N/A	N/A	N/A
Shifters	SRAM NX 11 speed	SRAM GX Eagle 12 speed	Shimano XT M8000
Brakes	SRAM Level T	SRAM Guide R	Shimano XT M8000
Rotors	Avid Centerline - 180mm	Avid Centerline - 180mm	Shimano RT86 Ice Tech - 180mm
Crankset	Race Face Aeffect 30t - 170mm (S), 175mm (M-XXL)	SRAM GX Eagle 30t - 170mm (S), 175mm (M-XXL)	Race Face Turbine 30t - 170mm (S), 175mm (M-XXL)
Cassette	SRAM XG1150 CS 10-42t	SRAM XG1275 Eagle 10-50t	E13 TRS Race 11 speed 9-46t
Chain	SRAM PC1110	SRAM GX Eagle 12 speed	Shimano SLX M7000
Handlebar	Race Face Aeffect R - 35x780mm, 20mm Rise	Race Face Aeffect R - 35x780mm, 20mm Rise	Santa Cruz AM Carbon Bar - 35x800mm
Stem	Race Face Ride - 50mm	Race Face Aeffect R - 50mm	Race Face Aeffect R - 50mm
Grips	Santa Cruz Palmdale Grips - Black	Santa Cruz Palmdale Grips - Black	Santa Cruz Palmdale Grips - Black
Headset	Cane Creek 10 IS Integrated Headset	Cane Creek 40 IS Integrated Headset	Cane Creek 110 IS Integrated Headset
Seatpost	Race Face Aeffect - 31.6x125mm (S-M), 150mm (L-XXL)	RockShox Reverb Stealth - 31.6x125mm (S), 150mm (M-L), 170mm (XL-XXL)	RockShox Reverb Stealth - 31.6x125mm (S), 150mm (M-L), 170mm (XL-XXL)
Saddle	WTB Volt Race	WTB Volt Race	WTB Silverado Pro
Front Tire	Maxxis Minion DHR 3C EXO TR 29x2.4"	Maxxis Minion DHR 3C EXO TR - 29x2.4"	Maxxis Minion DHR 3C EXO TR 29x2.4"
Rear Tire	Maxxis Minion DHR 3C EXO TR 29x2.4"	Maxxis Minion DHR 3C EXO TR 29x2.4"	Maxxis Minion DHR 3C EXO TR 29x2.4"
 Tubes/Sealant	Stan's Sealant	Stan's Sealant	Stan's Sealant
Front Hub	Novatec D711 - 15x110mm	Novatec D641 - 15x110mm	Novatec D641 - 15x110mm
Rear Hub	Novatec D462 - 12x148mm (XD)	Novatec D642 - 12x148mm (XD)	Novatec D642 - 12x148mm (XD)
Rim	WTB STP i29 TCS - 32h	E13 TRS 30mm - 32h	E13 TRS + 30mm - 32h
Spokes	DT Competition	DT Competition	DT Competition
Prezzo bici	€4.599,00	€5.399,00	€6.199,00

*Il rider Santa Cruz-SRAM
Mark Scott con la sua
Hightower LT in azione
all'Enduro World Series.
Foto Sven Martin*



BRONSON

La Bronson è forse la nostra bici più versatile. Con un'escursione da 150 mm gestita dal sistema VPP, pneumatici da 27,5 pollici e un angolo di sterzo di 66°, la Bronson è un perfetto equilibrio tra agilità e stabilità.

Combinata con una grande efficienza di pedalata e una personalità estremamente versatile è perfetta per lunghe giornate su terreni aggressivi.

I biker attivi ne apprezzeranno la sensazione di equilibrio e la personalità.

È l'accordo perfetto fra chi guida e il terreno sotto le ruote...

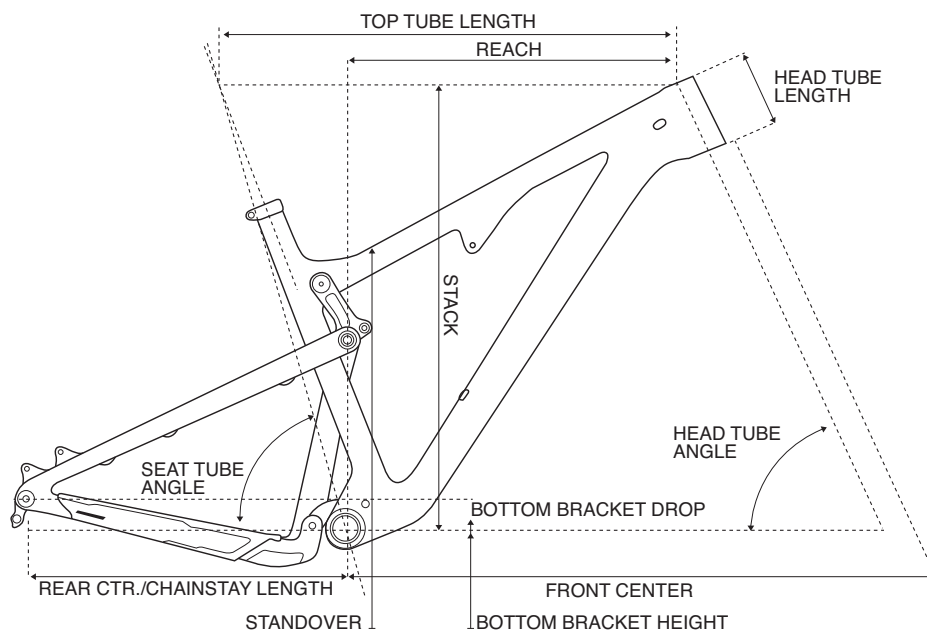

GEOMETRIA

	S	M	L	XL
Reach	405mm	425mm	445mm	475mm
Stack	586mm	595mm	605mm	614mm
Head Tube Angle	66°	66°	66°	66°
Head Tube Length	90mm	100mm	110mm	120mm
Seat Tube Angle	74°	74°	74°	74°
Seat Tube Length	395mm	420mm	460mm	495mm
Rear Center	432mm	432mm	432mm	432mm
Front Center	708mm	733mm	757mm	791mm
BB Height	341mm	341mm	341mm	341mm
BB Drop	13mm	13mm	13mm	13mm
Top Tube Length	573mm	596mm	618mm	651mm
Standover	727mm	731mm	734mm	747mm

CARATTERISTICHE

- 150 mm di escursione VPP.
- Pneumatici da 27,5".
- Opzione cerchi Santa Cruz Reserve 27 in carbonio sulle bici CC.
- Disponibile in carbonio CC, carbonio C e alluminio.
- Garanzia a vita per telaio e cuscinetti.
- Perfetta per: sentieri aggressivi ed enduro racing.
- A suo agio su: terreni pieni di radici, rocciosi, tecnici.
- Taglie: S, M, L, XL.
- Peso: 12,44-14,01 kg.
- Solo telaio/ammortizzatore a partire da: 2,87 kg.
- Colore: Gloss Carbon/Siracha - Gloss Olive/Black.



BRONSON CC
X01 27.5BRONSON CC
X01 27.5 RESERVEBRONSON CC
XX1 27.5BRONSON CC
XX1 27.5 RESERVE

	BRONSON CC X01 27.5	BRONSON CC X01 27.5 RESERVE	BRONSON CC XX1 27.5	BRONSON CC XX1 27.5 RESERVE
Frame	Carbon CC 27.5" 150mm Travel VPP™	Carbon CC 27.5" 150mm Travel VPP™	Carbon CC 27.5" 150mm Travel VPP™	Carbon CC 27.5" 150mm Travel VPP™
Shock	FOX Float Performance Elite DPX	FOX Float Performance Elite DPX	FOX Float Factory DPX Kashima	FOX Float Factory DPX Kashima
Fork	FOX 36 F150 Performance Elite	FOX 36 F150 Performance Elite	FOX 36 F150 Factory Kashima	FOX 36 F150 Factory Kashima
R. Derailleur	SRAM X01 Eagle 12 speed	SRAM X01 Eagle 12 speed	SRAM XX1 Eagle 12 speed	SRAM XX1 Eagle 12 speed
F. Derailleur	N/A	N/A	N/A	N/A
Chainguide	N/A	N/A	N/A	N/A
Shifters	SRAM X01 Eagle	SRAM X01 Eagle	SRAM XX1 Eagle 12 speed	SRAM XX1 Eagle 12 speed
Brakes	SRAM Guide RSC	SRAM Guide RSC	SRAM Guide Ultimate	SRAM Guide Ultimate
Rotors	Avid Centerline - 180mm	Avid Centerline - 180mm	Avid Centerline - 180mm	Avid Centerline - 180mm
Crankset	SRAM X1 Eagle Carbon 32t 170mm (S), 175mm (M-XL)	SRAM X1 Eagle Carbon 32t 170mm (S), 175mm (M-XL)	SRAM XX1 Eagle 32t 170mm (S), 175mm (M-XL)	SRAM XX1 Eagle 32t 170mm (S), 175mm (M-XL)
Cassette	SRAM XG1295 Eagle 10-50t	SRAM XG1295 Eagle 10-50t	SRAM XG1295 Eagle 10-50t	SRAM XG1295 Eagle 10-50t
Chain	SRAM X01 Eagle 12 speed	SRAM X01 Eagle 12 speed	SRAM XX1 Eagle 12 speed	SRAM XX1 Eagle 12 speed
Handlebar	Santa Cruz AM Carbon Bar 35x800mm	Santa Cruz AM Carbon Bar 35x800mm	Santa Cruz AM Carbon Bar - 35x800mm	Santa Cruz AM Carbon Bar 35x800mm
Stem	Race Face Aeffect R - 50mm	Race Face Aeffect R - 50mm	Race Face Turbine R - 50mm	Race Face Turbine R - 50mm
Grips	Santa Cruz Palmdale Grips - Black	Santa Cruz Palmdale Grips - Black	Santa Cruz Palmdale Grips - Black	Santa Cruz Palmdale Grips - Black
Headset	Cane Creek 40 ZS Headset	Cane Creek 40 ZS Headset	Cane Creek 110 ZS Headset	Cane Creek 110 ZS Headset
Seatpost	RockShox Reverb Stealth - 31.6x125mm (S), 150mm (M-L), 170mm (XL)	RockShox Reverb Stealth - 31.6x125mm (S), 150mm (M-L), 170mm (XL)	RockShox Reverb Stealth - 31.6x125mm (S), 150mm (M-L), 170mm (XL)	RockShox Reverb Stealth - 31.6x125mm (S), 150mm (M-L), 170mm (XL)
Saddle	WTB Silverado Pro	WTB Silverado Pro	WTB Silverado SLT	WTB Silverado SLT
Front Tire	Maxxis Minion DHF 3C EXO TR 27.5x2.3"	Maxxis Minion DHF 3C EXO TR 27.5x2.3"	Maxxis Minion DHF 3C EXO TR 27.5x2.3"	Maxxis Minion DHF 3C EXO TR 27.5x2.3"
Rear Tire	Maxxis Minion DHR2 EXO TR 27.5x2.3"	Maxxis Minion DHR2 EXO TR 27.5x2.3"	Maxxis Minion DHR2 EXO TR 27.5x2.3"	Maxxis Minion DHR2 EXO TR 27.5x2.3"
 Tubes/Sealant	Stan's Sealant	Stan's Sealant	Stan's Sealant	Stan's Sealant
Front Hub	DT 350 - 15x110mm, 28h	DT 350 - 15x110mm, 28h	i9 Torch Classic - 15x110mm, 28h	DT 350 - 15x110mm, 28h
Rear Hub	DT 350 - 12x148mm, 28h (XD)	DT 350 - 12x148mm, 28h (XD)	i9 Torch Classic - 12x148mm, 28h (XD)	i9 Torch Classic - 12x148mm, 28h (XD)
Rim	Race Face ARC 27 - 28h	Santa Cruz Reserve 27 Carbon - 28h	Race Face ARC 27 - 28h	Santa Cruz Reserve 27 Carbon - 28h
Spokes	DT Competition	DT Competition Race	DT Competition	DT Competition Race
Prezzo telaio	€3.599,00	€3.599,00	€3.599,00	€3.599,00
Prezzo bici	€7.399,00	€8.599,00	€8.699,00	€9.999,00

**BRONSON C
R 27.5**
**BRONSON C
S 27.5**
**BRONSON C
XE 27.5**

	BRONSON C R 27.5	BRONSON C S 27.5	BRONSON C XE 27.5
Frame	Carbon CC 27.5" 150mm Travel VPP™	Carbon C 27.5" 150mm Travel VPP™	Carbon C 27.5" 150mm Travel VPP™
Shock	FOX Float Performance DPS	FOX Float Performance DPS	FOX Float Performance Elite DPX
Fork	FOX Rhythm 34 150	FOX 36 F150 Performance	FOX 36 F150 Performance Elite
R. Derailleur	SRAM NX 11 speed Long Cage	SRAM GX Eagle 12 speed	Shimano XT M8000
F. Derailleur	N/A	N/A	N/A
Chainguide	N/A	N/A	N/A
Shifters	SRAM NX 11 speed	SRAM GX Eagle 12 speed	Shimano XT M8000
Brakes	SRAM Level T	SRAM Guide R	Shimano XT M8000
Rotors	Avid Centerline - 180mm	Avid Centerline - 180mm	Shimano RT86 Ice Tech - 180mm
Crankset	Race Face Aeffect 32t 170mm (S), 175mm (M-XL)	SRAM GX Eagle 32t 170mm (S), 175mm (M-XL)	Race Face Turbine 30t 170mm (S), 175mm (M-XL)
Cassette	SRAM XG1150 CS 10-42t	SRAM XG1275 Eagle 10-50t	E13 TRS Race 11 speed 9-46t
Chain	SRAM PC1110	SRAM GX Eagle 12 speed	Shimano SLX M7000
Handlebar	Race Face Aeffect R - 35x780mm, 20mm Rise	Race Face Aeffect R - 35x780mm, 20mm Rise	Santa Cruz AM Carbon Bar - 35x800mm
Stem	Race Face Ride - 50mm	Race Face Aeffect R - 50mm	Race Face Aeffect R - 50mm
Grips	Santa Cruz Palmdale Grips - Black	Santa Cruz Palmdale Grips - Black	Santa Cruz Palmdale Grips - Black
Headset	Cane Creek 10 ZS Headset	Cane Creek 40 ZS Headset	Cane Creek 40 ZS Headset
Seatpost	Race Face Aeffect 31.6x125mm (S-M), 150mm (L-XL)	RockShox Reverb Stealth - 31.6x125mm (S), 150mm (M-L), 170mm (XL)	RockShox Reverb Stealth - 31.6x125mm (S), 150mm (M-L), 170mm (XL)
Saddle	WTB Volt Race	WTB Volt Race	WTB Silverado Pro
Front Tire	Maxxis Minion DHF EXO TR 27.5x2.3"	Maxxis Minion DHF 3C EXO TR - 27.5x2.3"	Maxxis Minion DHF 3C EXO TR 27.5x2.3"
Rear Tire	Maxxis Minion DHR2 EXO TR 27.5x2.3"	Maxxis Minion DHR2 EXO TR - 27.5x2.3"	Maxxis Minion DHR2 EXO TR 27.5x2.3"
 Tubes/Sealant	Stan's Sealant	Stan's Sealant	Stan's Sealant
Front Hub	Novatec D711 - 15x110mm	Novatec D641 - 15x110mm	Novatec D641 - 15x110mm
Rear Hub	Novatec D462 - 12x148mm (XD)	Novatec D642 - 12x148mm (XD)	Novatec D642 - 12x148mm (XD)
Rim	WTB ST i25 TCS	Race Face AR 27 - 32h	Race Face AR 27 - 32h
Spokes	DT Competition	DT Competition Race	DT Competition
Prezzo bici	€4.499,00	€5.299,00	€5.999,00



BRONSON A R 27.5

BRONSON A S 27.5

Frame	Aluminum 27.5" 150mm Travel VPP™	Aluminum 27.5" 150mm Travel VPP™
Shock	FOX Float Performance DPS	FOX Float Performance DPS
Fork	FOX Rhythm 34 150	FOX 36 F150 Performance
R. Derailleur	SRAM NX 11 speed Long Cage	SRAM GX Eagle 12 speed
F. Derailleur	N/A	N/A
Chainguide	N/A	N/A
Shifters	SRAM NX 11 speed	SRAM GX Eagle 12 speed
Brakes	SRAM Level T	SRAM Guide R
Rotors	Avid Centerline - 180mm	Avid Centerline - 180mm
Crankset	Race Face Aeffect 32t 170mm (S), 175mm (M-XL)	SRAM GX Eagle 32t 170mm (S), 175mm (M-XL)
Cassette	SRAM XG1150 CS 10-42t	SRAM XG1275 Eagle 10-50t
Chain	SRAM X01 Eagle 12 speed	SRAM GX Eagle 12 speed
Handlebar	Race Face Aeffect R - 35x780mm, 20mm Rise	Race Face Aeffect R - 35x780mm, 20mm Rise
Stem	Race Face Ride - 50mm	Race Face Aeffect R - 50mm
Grips	Santa Cruz Palmdale Grips - Black	Santa Cruz Palmdale Grips - Black
Headset	Cane Creek 10 IS Integrated Headset	Cane Creek 40 IS Integrated Headset
Seatpost	Race Face Aeffect 31.6x125mm (S-M), 150mm (L-XL)	RockShox Reverb Stealth - 31.6x125mm (S), 150mm (M-L), 170mm (XL)
Saddle	WTB Volt Race	WTB Volt Race
Front Tire	Maxxis Minion DHF EXO TR 27.5x2.3"	Maxxis Minion DHF 3C EXO TR 27.5x2.3"
Rear Tire	Maxxis Minion DHR2 EXO TR 27.5x2.3"	Maxxis Minion DHR2 EXO TR 27.5x2.3"
Tubes/Sealant	Stan's Sealant	Stan's Sealant
Front Hub	Novatec D711 - 15x110mm	Novatec D641 - 15x110mm
Rear Hub	Novatec D462 - 12x148mm (XD)	Novatec D642 - 12x148mm (XD)
Rim	WTB ST i25 TCS	Race Face AR 27 - 32h
Spokes	DT Competition	DT Competition Race
Prezzo telaio	€2.299,00	€2.299,00
Prezzo bici	€3.899,00	€4.699,00

Juliana

RUBION CC XX1 27.5 RESERVE



	RUBION CC X01 27.5	RUBION CC X01 27.5 RESERVE	RUBION CC XX1 27.5	RUBION CC XX1 27.5 RESERVE
Frame	Carbon CC 27.5" 150mm Travel VPP™	Carbon CC 27.5" 150mm Travel VPP™	Carbon CC 27.5" 150mm Travel VPP™	Carbon CC 27.5" 150mm Travel VPP™
Shock	FOX Float Performance Elite DPX2	FOX Float Performance Elite DPX2	FOX Float Factory DPX2 Kashima	FOX Float Factory DPX2 Kashima
Fork	FOX 36 F150 Performance Elite	FOX 36 F150 Performance Elite	FOX 36 F150 Factory Kashima	FOX 36 F150 Factory Kashima
R. Derailleur	SRAM X01 Eagle 12 speed	SRAM X01 Eagle 12 speed	SRAM XX1 Eagle 12 speed	SRAM XX1 Eagle 12 speed
F. Derailleur	N/A	N/A	N/A	N/A
Chainguide	N/A	N/A	N/A	N/A
Shifters	SRAM X01 Eagle	SRAM X01 Eagle	SRAM XX1 Eagle 12 speed	SRAM XX1 Eagle 12 speed
Brakes	SRAM Guide RSC	SRAM Guide RSC	SRAM Guide Ultimate	SRAM Guide Ultimate
Rotors	Avid Centerline - 180mm	Avid Centerline - 180mm	Avid Centerline - 180mm	Avid Centerline - 180mm
Crankset	SRAM GX Eagle Carbon 32t - 170mm (S), 175mm (M-L)	SRAM GX Eagle Carbon 32t - 170mm (S), 175mm (M-L)	SRAM XX1 Eagle 32t - 170mm (S), 175mm (M-L)	SRAM XX1 Eagle 32t - 170mm (S), 175mm (M-L)
Cassette	SRAM XG1295 Eagle 10-50t	SRAM XG1295 Eagle 10-50t	SRAM XG1295 Eagle 10-50t	SRAM XG1295 Eagle 10-50t
Chain	SRAM X01 Eagle 12 speed	SRAM X01 Eagle 12 speed	SRAM XX1 Eagle 12 speed	SRAM XX1 Eagle 12 speed
Handlebar	Santa Cruz AM Carbon - 35x760mm	Santa Cruz AM Carbon - 35x760mm	Santa Cruz AM Carbon - 35x760mm	Santa Cruz AM Carbon - 35x760mm
Stem	Race Face Aeffect R - 50mm	Race Face Aeffect R - 50mm	Race Face Turbine R - 50mm	Race Face Turbine R - 50mm
Grips	Juliana grips - Crocodile Green	Juliana grips - Crocodile Green	Juliana grips - Crocodile Green	Juliana grips - Crocodile Green
Headset	Cane Creek 40 ZS Headset	Cane Creek 40 ZS Headset	Cane Creek 110 ZS Headset	Cane Creek 110 ZS Headset
Seatpost	RockShox Reverb Stealth - 31.6x125mm (S), 150mm (M-L)	RockShox Reverb Stealth - 31.6x125mm (S), 150mm (M-L)	RockShox Reverb Stealth - 31.6x125mm (S), 150mm (M-L)	RockShox Reverb Stealth - 31.6x125mm (S), 150mm (M-L)
Saddle	Juliana Primiero	Juliana Primiero	Juliana Carbon	Juliana Carbon
Front Tire	Maxxis Minion DHF 3C EXO TR 27.5x2.3"	Maxxis Minion DHF 3C EXO TR 27.5x2.3"	Maxxis Minion DHF 3C EXO TR 27.5x2.3"	Maxxis Minion DHF 3C EXO TR - 27.5x2.3"
Rear Tire	Maxxis Minion DHR2 EXO TR 27.5x2.3"	Maxxis Minion DHR2 EXO TR 27.5x2.3"	Maxxis Minion DHR2 EXO TR 27.5x2.3"	Maxxis Minion DHR2 EXO TR - 27.5x2.3"
 Tubes/Sealant	Stan's Sealant	Stan's Sealant	Stan's Sealant	Stan's Sealant
Front Hub	DT 350 - 15x110mm, 28h	DT 350 - 15x110mm, 28h	i9 Torch Classic - 15x110mm, 28h	i9 Torch Classic - 15x110mm, 28h
Rear Hub	DT 350 - 12x148mm, 28h (XD)	DT 350 - 12x148mm, 28h (XD)	i9 Torch Classic - 12x148mm, 28h (XD)	i9 Torch Classic - 12x148mm, 28h (XD)
Rim	Race Face ARC 27 - 28h	Santa Cruz Reserve 27 Carbon - 28h	Race Face ARC 27 - 28h	Santa Cruz Reserve 27 Carbon - 28h
Spokes	DT Competition	DT Competition Race	DT Competition	DT Competition Race
Prezzo telaio	€3.599,00	€3.599,00	€3.599,00	€3.599,00
Prezzo bici	€7.399,00	€8.599,00	€8.699,00	€9.999,00



RUBION C
R 27.5

RUBION C
S 27.5

RUBION C
XE 27.5

	RUBION C R 27.5	RUBION C S 27.5	RUBION C XE 27.5
Frame	Carbon C 27.5" 150mm Travel VPP™	Carbon C 27.5" 150mm Travel VPP™	Carbon C 27.5" 150mm Travel VPP™
Shock	FOX Float Performance DPS	FOX Float Performance DPS	FOX Float Performance Elite DPX2
Fork	FOX Rhythm 34 150	FOX 36 F150 Performance	FOX 36 F150 Performance Elite
R. Derailleur	SRAM NX 11 speed Long Cage	SRAM GX Eagle 12 speed	Shimano XT M8000
F. Derailleur	N/A	N/A	N/A
Chainguide	N/A	N/A	N/A
Shifters	SRAM NX 11 speed	SRAM GX Eagle 12 speed	Shimano XT M8000
Brakes	SRAM Level T	SRAM Guide R	Shimano XT M8000
Rotors	Avid Centerline - 180mm	Avid Centerline - 180mm	Shimano RT86 Ice Tech - 180mm
Crankset	Race Face Aeffect 30t - 170mm (S), 175mm (M-L)	SRAM GX Eagle Carbon 32t - 170mm (S), 175mm (M-L)	Race Face Turbine 30t 170mm (S), 175mm (M-L)
Cassette	SRAM XG1150 CS 10-42t	SRAM XG1275 Eagle 10-50t	E13 TRS Race 11 speed 9-46t
Chain	SRAM PC1110	SRAM GX Eagle 12 speed	Shimano SLX M7000
Handlebar	Race Face Ride - 35x760mm	Race Face Ride - 35x760mm	Santa Cruz AM Carbon - 35x760mm
Stem	Race Face Ride - 50mm	Race Face Aeffect R - 50mm	Race Face Aeffect R - 50mm
Grips	Juliana grips - Crocodile Green	Juliana grips - Crocodile Green	Juliana grips - Crocodile Green
Headset	Cane Creek 10 ZS Headset	Cane Creek 40 ZS Headset	Cane Creek 40 ZS Headset
Seatpost	Race Face Aeffect - 31.6x125mm (S-M), 150mm (L)	RockShox Reverb Stealth - 31.6x125mm (S), 150mm (M-L)	RockShox Reverb Stealth - 31.6x125mm (S), 150mm (M-L), 170mm (XL)
Saddle	Juliana Segundo	Juliana Segundo	Juliana Primiero
Front Tire	Maxxis Minion DHF EXO TR 27.5x2.3"	Maxxis Minion DHF 3C EXO TR 27.5x2.3"	Maxxis Minion DHF 3C EXO TR 27.5x2.3"
Rear Tire	Maxxis Minion DHR2 EXO TR 27.5x2.3"	Maxxis Minion DHR2 EXO TR 27.5x2.3"	Maxxis Minion DHR2 EXO TR 27.5x2.3"
Tubes/Sealant	Stan's Sealant	Stan's Sealant	Stan's Sealant
Front Hub	Novatec D711 - 15x110mm	Novatec D641 - 15x110mm	Novatec D641 - 15x110mm
Rear Hub	Novatec D462 - 12x148mm (XD)	Novatec D642 - 12x148mm (XD)	Novatec D642 - 12x148mm (XD)
Rim	WTB ST i25 TCS	Race Face AR 27 - 32h	Race Face AR 27 - 32h
Spokes	DT Competition	DT Competition	DT Competition
Prezzo bici	€ 4.499,00	€ 5.299,00	€ 5.999,00

NOMAD

È tutta nuova, tutta diversa eppure è sempre lei, la Santa Cruz Nomad. Angolo di sterzo aperto (64,5°), tubo piantone “in piedi” per essere pedalata alla grande, 170 mm di corsa e geometria regolabile. Chiedete a chi l’ha già provata con stupore.

È una Nomad, ma è anche un po’ una V10.

È una bici da enduro, ma è anche un mezzo per essere guidati dalla forza di gravità con molti meno timori.

Se hai quella cattiveria nella guida con la Santa Cruz Nomad puoi diventare una pallottola...

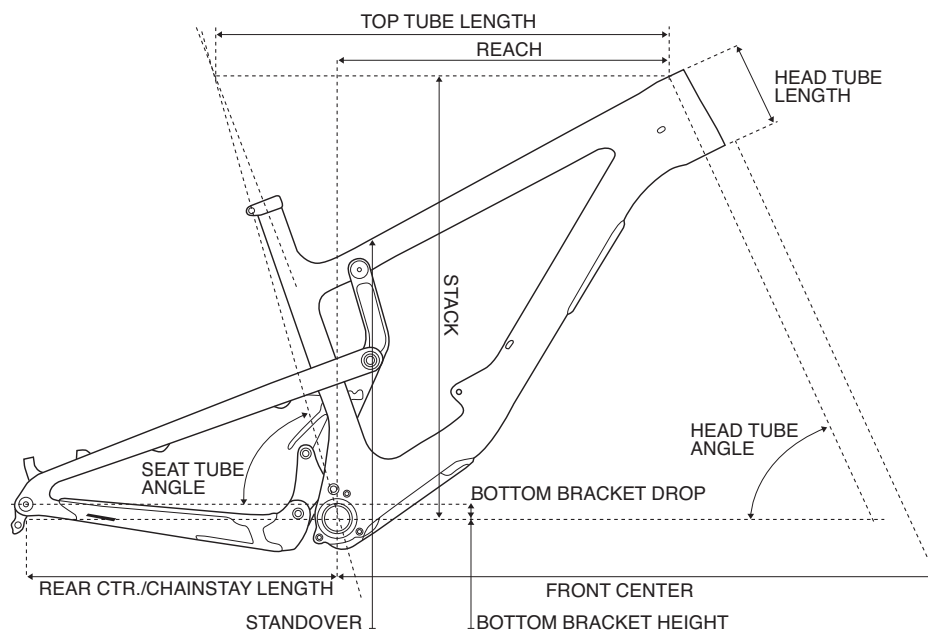

GEOMETRIA

	XS (Low / High)	S (Low / High)	M (Low / High)	L (Low / High)	XL (Low / High)
Reach	386 / 390mm	416 / 420mm	436 / 440mm	456 / 460mm	486 / 490mm
Stack	587 / 584mm	596 / 593mm	605 / 602mm	614 / 611mm	623 / 620mm
Head Tube Angle	64.6 / 65°	64.6 / 65°	64.6 / 65°	64.6 / 65°	64.6 / 65°
Head Tube Length	90 / 90mm	100 / 100mm	110 / 110mm	120 / 120mm	130 / 130mm
Seat Tube Angle	74.1 / 74.5°	74.1 / 74.5°	74.1 / 74.5°	74.1 / 74.5°	74.1 / 74.5°
Seat Tube Length	375 / 375mm	390 / 390mm	420 / 420mm	450 / 450mm	480 / 480mm
Rear Center	431 / 430mm	431 / 430mm	431 / 430mm	431 / 430mm	431 / 430mm
Front Center	704 / 704mm	738 / 738mm	762 / 762mm	787 / 787mm	821 / 821mm
BB Height	339 / 344mm	339 / 344mm	339 / 344mm	339 / 344mm	339 / 344mm
BB Drop	15 / 10mm	15 / 10mm	15 / 10mm	15 / 10mm	15 / 10mm
Top Tube Length	541 / 540mm	574 / 573mm	598 / 596mm	621 / 619mm	654 / 653mm
Standover	704 / 710mm	706 / 712mm	722 / 728mm	720 / 726mm	718 / 724mm

CARATTERISTICHE

- 170 mm di escursione VPP.
- Configurazione progressiva dell’ammortizzatore connesso al leveraggio inferiore della sospensione.
- Ammortizzatore con standard metrico.
- Shuttle guard imbullonato, protezione sul tubo obliquo e paraschizzi per ammortizzatore.
- Compatibile con ammortizzatori ad aria o a molla.
- Geometria variabile con flip-chip sul leveraggio.
- Pneumatici da 27,5”.
- Opzione cerchi Santa Cruz Reserve 30 in carbonio sulle bici CC.
- Disponibile in carbonio CC e C, lega disponibile in autunno.
- Garanzia a vita per telaio e cuscinetti.
- Taglie: XS, S, M, L, XL.

- Peso: versione XX1 con ruote Reserve taglia L (ammo ad aria): 13,39 kg; (ammo a molla): 13,88 kg.
- Colore: Tan/Black - Ink Blue/Gold.



NOMAD CC
X01 27.5NOMAD CC
X01 27.5 RESERVENOMAD CC
XX1 27.5NOMAD CC
XX1 27.5 RESERVE

	NOMAD CC X01 27.5	NOMAD CC X01 27.5 RESERVE	NOMAD CC XX1 27.5	NOMAD CC XX1 27.5 RESERVE
Frame	Carbon CC 27.5" 170mm Travel VPP™	Carbon CC 27.5" 170mm Travel VPP™	Carbon CC 27.5" 170mm Travel VPP™	Carbon CC 27.5" 170mm Travel VPP™
Shock	RockShox Super Deluxe Coil RCT or Super Deluxe Air RCT	RockShox Super Deluxe Coil RCT or Super Deluxe Air RCT	RockShox Super Deluxe Coil RCT or Super Deluxe Air RCT	RockShox Super Deluxe Coil RCT or Super Deluxe Air RCT
Fork	RockShox Lyrik RCT3 170	RockShox Lyrik RCT3 170	RockShox Lyrik RCT3 170	RockShox Lyrik RCT3 170
R. Derailleur	SRAM X01 Eagle 12 speed	SRAM X01 Eagle 12 speed	SRAM XX1 Eagle 12 speed	SRAM XX1 Eagle 12 speed
F. Derailleur	N/A	N/A	N/A	N/A
Chainguide	E13 TRS + 1x Guide ISCG05	E13 TRS + 1x Guide ISCG05	E13 TRS + 1x Guide ISCG05	E13 TRS + 1x Guide ISCG05
Shifters	SRAM X01 Eagle	SRAM X01 Eagle	SRAM XX1 Eagle 12 speed	SRAM XX1 Eagle 12 speed
Brakes	SRAM Code RSC	SRAM Code RSC	SRAM Code RSC	SRAM Code RSC
Rotors	Avid Centerline - 180mm	Avid Centerline - 180mm	Avid Centerline - 180mm	Avid Centerline - 180mm
Crankset	SRAM X1 Eagle Carbon 32t - 170mm	SRAM X1 Eagle Carbon 32t - 170mm	SRAM XX1 Eagle 32t 170mm (S), 175mm (M-XL)	SRAM XX1 Eagle 32t - 170mm
Cassette	SRAM XG1295 Eagle 10-50t	SRAM XG1295 Eagle 10-50t	SRAM XG1295 Eagle 10-50t	SRAM XG1295 Eagle 10-50t
Chain	SRAM X01 Eagle 12 speed	SRAM X01 Eagle 12 speed	SRAM XX1 Eagle 12 speed	SRAM XX1 Eagle 12 speed
Handlebar	Santa Cruz AM Carbon Bar 35x800mm	Santa Cruz AM Carbon Bar 35x800mm	Santa Cruz AM Carbon Bar 35x800mm	Santa Cruz AM Carbon Bar 35x800mm
Stem	Race Face Aeffect R - 50mm	Race Face Aeffect R - 50mm	Race Face Turbine R - 50mm	Race Face Turbine R - 50mm
Grips	Santa Cruz Palmdale Grips - Black	Santa Cruz Palmdale Grips - Black	Santa Cruz Palmdale Grips - Black	Santa Cruz Palmdale Grips - Black
Headset	Cane Creek 40 IS Integrated Headset	Cane Creek 40 IS Integrated Headset	Cane Creek 110 IS Integrated Headset	Cane Creek 110 IS Integrated Headset
Seatpost	RockShox Reverb Stealth - 31.6x100mm (XS), 125mm (S), 150mm (M), 170mm (L-XL)	RockShox Reverb Stealth - 31.6x100mm (XS), 125mm (S), 150mm (M), 170mm (L-XL)	RockShox Reverb Stealth - 31.6x100mm (XS), 125mm (S), 150mm (M), 170mm (L-XL)	RockShox Reverb Stealth - 31.6x100mm (XS), 125mm (S), 150mm (M), 170mm (L-XL)
Saddle	WTB Hightail Pro (XS-S), WTB Volt Race (M-XL)	WTB Hightail Pro (XS-S), WTB Volt Race (M-XL)	WTB Hightail Pro (XS-S), WTB Volt Race (M-XL)	WTB Hightail Pro (XS-S), WTB Volt Race (M-XL)
Front Tire	Maxxis Minion DHF 3C EXO TR 27.5x2.5"	Maxxis Minion DHF 3C EXO TR 27.5x2.5"	Maxxis Minion DHF 3C EXO TR 27.5x2.5"	Maxxis Minion DHF 3C EXO TR 27.5x2.5"
Rear Tire	Maxxis Minion DHR II EXO TR 27.5x2.4"	Maxxis Minion DHR II EXO TR 27.5x2.4"	Maxxis Minion DHR II EXO TR 27.5x2.4"	Maxxis Minion DHR II EXO TR 27.5x2.4"
Tubes/Sealant	Stan's Sealant	Stan's Sealant	Stan's Sealant	Stan's Sealant
Front Hub	DT 350 - 15x110mm, Torque Cap	DT 350 - 15x110mm, 28h, Torque Cap	i9 Torch Classic - 15x110mm, 28h, Torque Cap	i9 Torch Classic - 15x110mm, 28h, Torque Cap
Rear Hub	DT 350 - 12x148mm, (XD)	DT 350 - 12x148mm, 28h (XD)	i9 Torch Classic - 12x148mm, 28h (XD)	i9 Torch Classic - 12x148mm, 28h (XD)
Rim	E13 TRS + 30mm - 28h	Santa Cruz Reserve 30 Carbon - 28h	E13 TRS + 30mm - 28h	Santa Cruz Reserve 30 Carbon - 28h
Spokes	DT Competition	DT Competition Race	DT Competition	DT Competition Race
Prezzo telaio	€ 3.899,00	€ 3.899,00	€ 3.899,00	€ 3.899,00
Prezzo bici	€ 7.499,00	€ 8.899,00	€ 8.699,00	€ 9.999,00



NOMAD C
R 27.5

NOMAD C
S 27.5

NOMAD C
XE 27.5

Frame	Carbon C 27.5" 170mm Travel VPP™	Carbon C 27.5" 170mm Travel VPP™	Carbon C 27.5" 170mm Travel VPP™
Shock	RockShox Super Deluxe R	RockShox Super Deluxe R	RockShox Super Deluxe Coil RCT or Super Deluxe Air RCT
Fork	RockShox Yari RC 170	RockShox Lyrik RC 170	RockShox Lyrik RCT3 170
R. Derailleur	SRAM NX 11 speed Long Cage	SRAM GX Eagle 12 speed	Shimano XT M8000
F. Derailleur	N/A	N/A	N/A
Chainguide	E13 TRS Race SL ISCG05	E13 TRS + 1x Guide ISCG05	E13 TRS + 1x Guide ISCG05
Shifters	SRAM NX 11 speed	SRAM GX Eagle 12 speed	Shimano XT M8000
Brakes	SRAM Guide R	SRAM Code R	SRAM Code RSC
Rotors	Avid Centerline - 200mm	Avid Centerline - 180mm	Avid Centerline - 180mm
Crankset	Race Face Aeffect 30t - 170mm	SRAM GX Eagle 32t - 170mm	Race Face Turbine 30t - 170mm
Cassette	SRAM XG1150 CS 10-42t	SRAM XG1275 Eagle 10-50t	E13 TRS Race 11 speed 9-46t
Chain	SRAM PC1110	SRAM GX Eagle 12 speed	Shimano SLX M7000
Handlebar	Race Face Aeffect R - 35x780mm, 20mm Rise	Race Face Aeffect R - 35x780mm, 20mm Rise	Santa Cruz AM Carbon Bar - 35x800mm
Stem	Race Face Ride - 50mm	Race Face Aeffect R - 50mm	Race Face Aeffect R - 50mm
Grips	Santa Cruz Palmdale Grips - Black	Santa Cruz Palmdale Grips - Black	Santa Cruz Palmdale Grips - Black
Headset	Cane Creek 10 IS Integrated Headset	Cane Creek 40 IS Integrated Headset	Cane Creek 40 IS Integrated Headset
Seatpost	Race Face Aeffect - 31.6x125mm (XS-M), 150mm (L-XL)	RockShox Reverb Stealth - 31.6x100mm (XS), 125mm (S), 150mm (M), 170mm (L-XL)	RockShox Reverb Stealth - 31.6x100mm (XS), 125mm (S), 150mm (M), 170mm (L-XL)
Saddle	WTB Hightail Pro (XS-S), WTB Volt Race (M-XL)	WTB Hightail Pro (XS-S), WTB Volt Race (M-XL)	WTB Hightail Pro (XS-S), WTB Volt Race (M-XL)
Front Tire	Maxxis Minion DHF 3C EXO TR 27.5x2.5"	Maxxis Minion DHF 3C EXO TR 27.5x2.5"	Maxxis Minion DHF 3C EXO TR 27.5x2.5"
Rear Tire	Maxxis Minion DHR II EXO TR 27.5x2.4"	Maxxis Minion DHR II EXO TR 27.5x2.4"	Maxxis Minion DHR II EXO TR 27.5x2.4"
 Tubes/Sealant	Stan's Sealant	Stan's Sealant	Stan's Sealant
Front Hub	Novatec D711 - 15x110mm	Novatec D641 - 15x110mm	Novatec D641 - 15x110mm
Rear Hub	Novatec D462 - 12x148mm (XD)	Novatec D642 - 12x148mm (XD)	Novatec D642 - 12x148mm (XD)
Rim	WTB ST i29 TCS	E13 TRS 30mm - 32h	E13 TRS 30mm - 32h
Spokes	DT Competition	DT Competition	DT Competition
Prezzo bici	€4.799,00	€5.499,00	€6.299,00

NOMAD A
R 27.5NOMAD A
S 27.5

Frame	Aluminum 27.5" 170mm Travel VPP™	Aluminum 27.5" 170mm Travel VPP™
Shock	RockShox Super Deluxe R	RockShox Super Deluxe R
Fork	RockShox Yari RC 170	RockShox Lyrik RC 170
R. Derailleur	SRAM NX 11 speed Long Cage	SRAM GX Eagle 12 speed
F. Derailleur	N/A	N/A
Chainguide	E13 TRS Race SL ISCG05	E13 TRS + 1x Guide ISCG05
Shifters	SRAM NX 11 speed	SRAM GX Eagle 12 speed
Brakes	SRAM Guide R	SRAM Code R
Rotors	Avid Centerline - 200mm	Avid Centerline - 180mm
Crankset	Race Face Aeffect 30t - 170mm	SRAM GX Eagle 32t - 170mm
Cassette	SRAM XG1150 CS 10-42t	SRAM XG1275 Eagle 10-50t
Chain	SRAM PC1110	SRAM GX Eagle 12 speed
Handlebar	Race Face Aeffect R - 35x780mm, 20mm Rise	Race Face Aeffect R - 35x780mm, 20mm Rise
Stem	Race Face Ride - 50mm	Race Face Aeffect R - 50mm
Grips	Santa Cruz Palmdale Grips - Black	Santa Cruz Palmdale Grips - Black
Headset	Cane Creek 10 IS Integrated Headset	Cane Creek 40 IS Integrated Headset
Seatpost	Race Face Aeffect - 31.6x125mm (S-M), 150mm (L-XL)	RockShox Reverb Stealth - 31.6x125mm (S), 150mm (M-L), 170mm (XL)
Saddle	WTB Hightail Pro (S), WTB Volt Race (M-XL)	WTB Hightail Pro (S), WTB Volt Race (M-XL)
Front Tire	Maxxis Minion DHF 3C EXO TR 27.5x2.5"	Maxxis Minion DHF 3C EXO TR 27.5x2.5"
Rear Tire	Maxxis Minion DHR II EXO TR 27.5x2.4"	Maxxis Minion DHR II EXO TR 27.5x2.4"
Tubes/Sealant	Stan's Sealant	Stan's Sealant
Front Hub	Novatec D711 - 15x110mm	Novatec D641 - 15x110mm
Rear Hub	Novatec D462 - 12x148mm (XD)	Novatec D642 - 12x148mm (XD)
Rim	WTB ST i29 TCS	E13 TRS 30mm - 32h
Spokes	DT Competition	DT Competition Race
Prezzo telaio	€2.299,00	€2.299,00
Prezzo bici	€3.999,00	€4.699,00

Juliana

STREGA CC XX1 27.5 RESERVE



STREGA CC
X01 27.5

STREGA CC
X01 27.5 RESERVE

STREGA CC
XX1 27.5

STREGA CC
XX1 27.5 RESERVE

	STREGA CC X01 27.5	STREGA CC X01 27.5 RESERVE	STREGA CC XX1 27.5	STREGA CC XX1 27.5 RESERVE
Frame	Carbon CC 27.5" 170mm Travel VPP™	Carbon CC 27.5" 170mm Travel VPP™	Carbon CC 27.5" 170mm Travel VPP™	Carbon CC 27.5" 170mm Travel VPP™
Shock	RockShox Super Deluxe RCT	RockShox Super Deluxe RCT	RockShox Super Deluxe RCT	RockShox Super Deluxe RCT
Fork	RockShox Lyrik RCT3 170	RockShox Lyrik RCT3 170	RockShox Lyrik RCT3 170	RockShox Lyrik RCT3 170
R. Derailleur	SRAM X01 Eagle 12 speed	SRAM X01 Eagle 12 speed	SRAM XX1 Eagle 12 speed	SRAM XX1 Eagle 12 speed
F. Derailleur	N/A	N/A	N/A	N/A
Chainguide	E13 TRS + 1x Guide ISCG05	E13 TRS + 1x Guide ISCG05	E13 TRS + 1x Guide ISCG05	E13 TRS + 1x Guide ISCG05
Shifters	SRAM X01 Eagle	SRAM X01 Eagle	SRAM XX1 Eagle 12 speed	SRAM XX1 Eagle 12 speed
Brakes	SRAM Code RSC	SRAM Code RSC	SRAM Code RSC	SRAM Code RSC
Rotors	Avid Centerline - 180mm	Avid Centerline - 180mm	Avid Centerline - 180mm	Avid Centerline - 180mm
Crankset	SRAM X1 Eagle Carbon 32t - 170mm	SRAM X1 Eagle Carbon 32t - 170mm	SRAM XX1 Eagle 32t - 170mm	SRAM XX1 Eagle 32t - 170mm
Cassette	SRAM XG1295 Eagle 10-50t	SRAM XG1295 Eagle 10-50t	SRAM XG1295 Eagle 10-50t	SRAM XG1295 Eagle 10-50t
Chain	SRAM X01 Eagle 12 speed	SRAM X01 Eagle 12 speed	SRAM XX1 Eagle 12 speed	SRAM XX1 Eagle 12 speed
Handlebar	Santa Cruz AM Carbon Bar 35x800mm	Santa Cruz AM Carbon Bar 35x800mm	Santa Cruz AM Carbon Bar - 35x800mm	Santa Cruz AM Carbon Bar 35x800mm
Stem	Race Face Aeffect R - 50mm	Race Face Aeffect R - 50mm	Race Face Turbine R - 50mm	Race Face Turbine R - 50mm
Grips	Juliana grips - Black	Juliana grips - Black	Juliana grips - Black	Juliana grips - Black
Headset	Cane Creek 40 IS Integrated Headset	Cane Creek 40 IS Integrated Headset	Cane Creek 110 IS Integrated Headset	Cane Creek 110 IS Integrated Headset
Seatpost	RockShox Reverb Stealth - 31.6x100mm (XS), 125mm (S), 150mm (M)	RockShox Reverb Stealth - 31.6x100mm (XS), 125mm (S), 150mm (M)	RockShox Reverb Stealth - 31.6x100mm (XS), 125mm (S), 150mm (M)	RockShox Reverb Stealth - 31.6x100mm (XS), 125mm (S), 150mm (M)
Saddle	WTB Hightail Pro (XS-S), Juliana Primiero (M)	WTB Hightail Pro (XS-S), Juliana Primiero (M)	WTB Hightail Pro (XS-S), Juliana Carbon (M)	WTB Hightail Pro (XS-S), Juliana Carbon (M)
Front Tire	Maxxis Minion DHF 3C EXO TR 27.5x2.5"	Maxxis Minion DHF 3C EXO TR 27.5x2.5"	Maxxis Minion DHF 3C EXO TR 27.5x2.5"	Maxxis Minion DHF 3C EXO TR 27.5x2.5"
Rear Tire	Maxxis Minion DHR II EXO TR 27.5x2.4"	Maxxis Minion DHR II EXO TR - 27.5x2.4"	Maxxis Minion DHR II EXO TR 27.5x2.4"	Maxxis Minion DHR II EXO TR 27.5x2.4"
 Tubes/Sealant	Stan's Sealant	Stan's Sealant	Stan's Sealant	Stan's Sealant
Front Hub	DT 350 - 15x110mm, 28h, Torque Cap	DT 350 - 15x110mm, 28h, Torque Cap	i9 Torch Classic - 15x110mm, 28h, Torque Cap	i9 Torch Classic - 15x110mm, 28h, Torque Cap
Rear Hub	DT 350 - 12x148mm, 28h (XD)	DT 350 - 12x148mm, 28h (XD)	i9 Torch Classic - 12x148mm, 28h (XD)	i9 Torch Classic - 12x148mm, 28h (XD)
Rim	E13 TRS + 30mm - 28h	Santa Cruz Reserve 30 Carbon - 28h	E13 TRS + 30mm - 28h	Santa Cruz Reserve 30 Carbon - 28h
Spokes	DT Competition	DT Competition Race	DT Competition	DT Competition Race
Prezzo telaio	€3.899,00	€3.899,00	€3.899,00	€3.899,00
Prezzo bici	€7.499,00	€8.899,00	€8.699,00	€9.999,00



STREGA C
R 27.5

STREGA C
S 27.5

STREGA C
XE 27.5

	STREGA C R 27.5	STREGA C S 27.5	STREGA C XE 27.5
Frame	Carbon C 27.5" 170mm Travel VPP™	Carbon C 27.5" 170mm Travel VPP™	Carbon C 27.5" 170mm Travel VPP™
Shock	RockShox Super Deluxe R	RockShox Super Deluxe R	RockShox Super Deluxe RCT
Fork	RockShox Yari RC 170	RockShox Lyrik RC 170	RockShox Lyrik RCT3 170
R. Derailleur	SRAM NX 11 speed Long Cage	SRAM GX Eagle 12 speed	Shimano XT M8000
F. Derailleur	N/A	N/A	N/A
Chainguide	E13 TRS Race SL ISCG05	E13 TRS + 1x Guide ISCG05	E13 TRS + 1x Guide ISCG05
Shifters	SRAM NX 11 speed	SRAM GX Eagle 12 speed	Shimano XT M8000
Brakes	SRAM Guide R	SRAM Code R	SRAM Code RSC
Rotors	Avid Centerline - 200mm	Avid Centerline - 180mm	Avid Centerline - 180mm
Crankset	Race Face Aeffect 30t - 170mm	SRAM GX Eagle 32t - 170mm	Race Face Turbine 30t - 170mm
Cassette	SRAM XG1150 CS 10-42t	SRAM XG1275 Eagle 10-50t	E13 TRS Race 11 speed 9-46t
Chain	SRAM PC1110	SRAM GX Eagle 12 speed	Shimano SLX M7000
Handlebar	Race Face Aeffect R - 35x780mm, 20mm Rise	Race Face Aeffect R - 35x780mm, 20mm Rise	Santa Cruz AM Carbon Bar - 35x800mm
Stem	Race Face Ride - 50mm	Race Face Aeffect R - 50mm	Race Face Aeffect R - 50mm
Grips	Juliana grips - Black	Juliana grips - Black	Juliana grips - Black
Headset	Cane Creek 10 IS Integrated Headset	Cane Creek 40 IS Integrated Headset	Cane Creek 40 IS Integrated Headset
Seatpost	Race Face Aeffect - 31.6x125mm	RockShox Reverb Stealth - 31.6x100mm (XS), 125mm (S), 150mm (M)	RockShox Reverb Stealth - 31.6x100mm (XS), 125mm (S), 150mm (M)
Saddle	WTB Hightail Pro (XS-S), Juliana Segundo (M)	WTB Hightail Pro (XS-S), Juliana Segundo (M)	WTB Hightail Pro (XS-S), Juliana Primero (M)
Front Tire	Maxxis Minion DHF 3C EXO TR 27.5x2.5"	Maxxis Minion DHF 3C EXO TR 27.5x2.5"	Maxxis Minion DHF 3C EXO TR - 27.5x2.5"
Rear Tire	Maxxis Minion DHR II EXO TR 27.5x2.4"	Maxxis Minion DHR II EXO TR 27.5x2.4"	Maxxis Minion DHR II EXO TR - 27.5x2.4"
 Tubes/Sealant	Stan's Sealant	Stan's Sealant	Stan's Sealant
Front Hub	Novatec D711 - 15x110mm	Novatec D641 - 15x110mm	Novatec D641 - 15x110mm
Rear Hub	Novatec D462 - 12x148mm (XD)	Novatec D642 - 12x148mm (XD)	Novatec D642 - 12x148mm (XD)
Rim	WTB ST i29 TCS	E13 TRS 30mm - 32h	E13 TRS 30mm - 28h
Spokes	DT Competition	DT Competition	DT Competition
Prezzo bici	€4.799,00	€5.499,00	€6.299,00

V10

È stata una delle prime Mtb da Dh con telaio in fibra di carbonio ed è stata da subito una delle più veloci e vincenti in campo Dh in Coppa del mondo.

La Santa Cruz V10 è l'estremizzazione della sospensione con disegno Vpp (216 mm di corsa posteriore) con geometria regolabile (settaggi High e Low) e quattro taglie.

La puoi scegliere con allestimento CC oppure C e qualunque sarà il montaggio ti sentirai un po' più vicino alle emozioni che provano in gara Greg Minnaar, Loris Vergier e Luca Shaw.

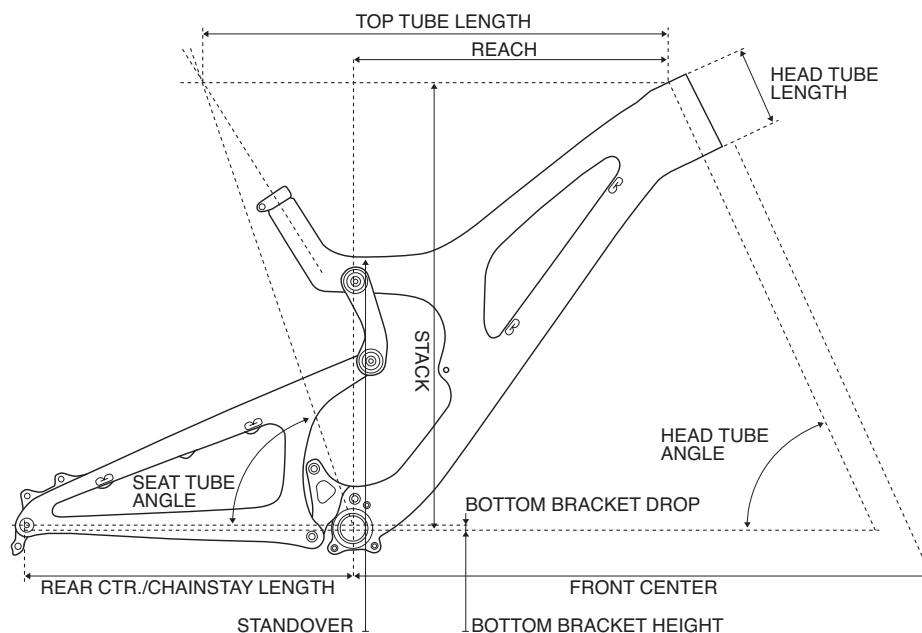

GEOMETRIA	S (High/Low)	M (High/Low)	L (High/Low)	XL (High/Low)	XXL (High/Low)
Reach	383 / 378mm	403 / 398mm	424 / 419mm	451 / 446mm	470 / 465mm
Stack	592 / 596mm	592 / 596mm	601 / 604mm	610 / 614mm	619 / 623mm
Head Tube Angle	64 / 63.5°	64 / 63.5°	64 / 63.5°	64 / 63.5°	64 / 63.5°
Head Tube Length	100 / 100mm	100 / 100mm	110 / 110mm	120 / 120mm	130 / 130mm
Seat Tube Angle	72.5 / 72°	72 / 71.5°	71.5 / 71°	71.5 / 71°	71.5 / 71°
Seat Tube Length	445 / 445mm	457 / 457mm	464 / 464mm	470 / 470mm	470 / 470mm
Rear Center	440 / 442mm	440 / 442mm	440 / 442mm	440 / 442mm	450 / 452mm
Front Center	733 / 733mm	752 / 752mm	778 / 778mm	809 / 809mm	833 / 833mm
BB Height	360 / 354mm	360 / 354mm	360 / 354mm	360 / 354mm	360 / 354mm
BB Drop	-6 / 1mm	-6 / 1mm	-6 / 1mm	-6 / 1mm	-6 / 1mm
Top Tube Length	570 / 572mm	595 / 597mm	625 / 627mm	655 / 657mm	677 / 679mm
Standover	731 / 724mm	731 / 725mm	729 / 722mm	728 / 722mm	728 / 722mm

CARATTERISTICHE

- 216 mm di escursione VPP.
- Pneumatici da 27,5".
- Geometria regolabile - Alta: 64° HTA/360 mm BB;
Bassa: 63,5° HTA /353 mm BB.
- Sentieri di gara DH, bike park.
- Disponibile in carbonio CC e carbonio C.
- Garanzia a vita per telaio e cuscinetto.
- Perfetta per: vincere la Coppa del Mondo downhill.
- A suo agio su: percorsi DH ripidi con sassi, radici e gap jump.
- Taglie: S, M, L, XL, XXL.
- Peso: 14,76-16,24 kg.
- Solo telaio/ammortizzatore: 3,46 kg.

- Colore: Gloss Blue/Mint - Matte Black/White.





V10 CC DH X01 27.5 DHX2

V10 CC DH X01 27.5 DHX2 ENVE

Frame	Carbon CC 27.5" 216mm Travel VPP™	Carbon CC 27.5" 216mm Travel VPP™
Shock	FOX DHX2 Factory Kashima	FOX DHX2 Factory Kashima
Fork	FOX 40 Float RC2 203	FOX 40 Float RC2 203
R. Derailleur	SRAM X01 DH 7 speed	SRAM X01 DH 7 speed
F. Derailleur	N/A	N/A
Chainguide	E13 LG1+ 38t	E13 LG1+ 38t
Shifters	SRAM X01 DH	SRAM X01 DH
Brakes	SRAM Code RSC	SRAM Code RSC
Rotors	Avid Centerline - 203mm	Avid Centerline - 203mm
Crankset	Race Face SIXC	Race Face SIXC
Cassette	SRAM X01 DH Cassette 7 speed	SRAM X01 DH Cassette 7 speed
Chain	SRAM XX1	SRAM XX1
Handlebar	Santa Cruz AM Carbon Bar 35x800mm	Santa Cruz AM Carbon Bar - 35x800mm
Stem	Santa Cruz Direct Mount 35x45/50mm	Santa Cruz Direct Mount 35x45/50mm
Grips	Santa Cruz Palmdale Grips - Black	Santa Cruz Palmdale Grips - Black
Headset	Cane Creek 40 Flush for 1.5 Headtube	Cane Creek 40 Flush for 1.5 Headtube
Seatpost	Thomson - 30.9	Thomson - 30.9
Saddle	WTB High Tail Team	WTB High Tail Team
Front Tire	Maxxis High Roller 2 DH TR 3C - 27.5x2.4"	Maxxis High Roller 2 DH TR 3C - 27.5x2.4"
Rear Tire	Maxxis High Roller 2 DH TR 3C - 27.5x2.4"	Maxxis High Roller 2 DH TR 3C - 27.5x2.4"
 Tubes/Sealant	Stan's Sealant	Stan's Sealant
Front Hub	i9 Torch Classic - 20x110mm	i9 Torch Classic - 20x110mm
Rear Hub	i9 Torch Classic - 12x157mm	i9 Torch Classic - 12x157mm
Rim	E13 LG1+ 650 - 32h	ENVE M90 - 32h
Spokes	DT Competition	DT Competition
Prezzo telaio	€4.499,00	€4.499,00
Prezzo bici	€9.499,00	€11.999,00





V10 C DH S 27.5

Frame	Carbon C 27.5" 216mm Travel VPP™
Shock	FOX DHX2 Performance Elite
Fork	FOX 40 Float Performance Elite
R. Derailleur	SRAM GX DH 7 speed
F. Derailleur	N/A
Chainguide	E13 LG1+ 38t
Shifters	SRAM GX 7 speed
Brakes	SRAM Code R
Rotors	Avid Centerline - 203mm
Crankset	SRAM Descendant DH 36t
Cassette	SRAM PG720 DH 11-25t
Chain	SRAM PC1110
Handlebar	Race Face ATLAS - 35X800mm, 20mm Rise
Stem	Santa Cruz Direct Mount 35x45/50mm
Grips	Santa Cruz Palmdale Grips - Black
Headset	Cane Creek 40 Flush for 1.5 Headtube
Seatpost	Thomson - 30.9
Saddle	WTB High Tail Pro
Front Tire	Maxxis High Roller 2 DH TR 3C - 27.5x2.4"
Rear Tire	Maxxis High Roller 2 DH TR 3C - 27.5x2.4"
Tubes/Sealant	Stan's Sealant
Front Hub	Novatec D641 - 20x110mm
Rear Hub	Novatec DH42 -12x157mm
Rim	E13 LG1+ 650 - 32h
Spokes	DT Competition
Prezzo bici	€6.499,00



HIGHBALL 27.5

Santa Cruz è famosa per le bici dedicate al divertimento e la gamma Highball rappresenta il suo sguardo più Xc racing.

La Highball è una hardtail in fibra di carbonio pensata per essere abbinata a una forcella da 100 mm di corsa.

È disponibile sia la versione per ruote da 29 pollici che quella per ruote da 27,5 pollici.

Se conoscete bene Santa Cruz saprete allora come viene lavorata e sviluppata la fibra di carbonio. Il resto è solo una questione di forza e passione. È il compito di chi sta in sella alla Santa Cruz Highball.

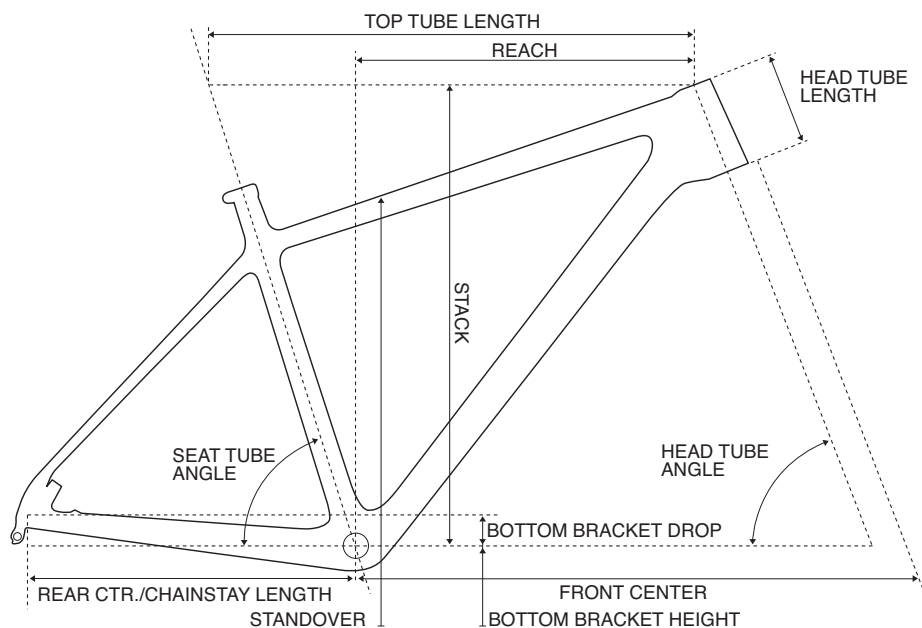

GEOMETRIA

	S	M	L	XL
Reach	393mm	415mm	438mm	460mm
Stack	576mm	585mm	595mm	604mm
Head Tube Angle	69°	69°	69°	69°
Head Tube Length	100mm	110mm	120mm	130mm
Seat Tube Angle	72.5°	72.5°	72.5°	72.5°
Seat Tube Length	406mm	432mm	483mm	533mm
Rear Center	425mm	425mm	425mm	425mm
Front Center	644mm	670mm	696mm	722mm
BB Height	314mm	314mm	314mm	314mm
BB Drop	40mm	40mm	40mm	40mm
Top Tube Length	575mm	600mm	625mm	651mm
Standover	719mm	735mm	759mm	796mm

CARATTERISTICHE

- Hardtail concepita per forcella da 100 mm di escursione.
- Versione per ruote da 27,5 pollici.
- Opzione cerchi Santa Cruz Reserve 25 in carbonio sulle bici CC.
- Disponibile in carbonio CC, carbonio C e alluminio.
- Garanzia a vita per il telaio.
- Perfetta per: gare XC, pedalata su sentieri regolari.
- A suo agio su: dal cross country al trail fluido.
- Taglie: S, M, L, XL.
- Peso: 9,74-12,47 kg.
- Solo telaio a partire da: 1,19 kg.
- Colore: Gloss Grey/Red - Matte Black/White.



HIGHBALL 27.5 C
RHIGHBALL 27.5 C
SHIGHBALL 27.5 CC
X01

	HIGHBALL 27.5 C R	HIGHBALL 27.5 C S	HIGHBALL 27.5 CC X01
Frame	Carbon C 27.5" Hardtail	Carbon C 27.5" Hardtail	Carbon CC 27.5" Hardtail
Shock	N/A	N/A	N/A
Fork	RockShox Reba RL 100	RockShox SID RL 100	RockShox SID RLC 100
R. Derailleur	SRAM NX 11 speed Long Cage	SRAM GX Eagle 12 speed	SRAM X01 Eagle 12 speed
F. Derailleur	N/A	N/A	N/A
Chainguide	N/A	N/A	N/A
Shifters	SRAM NX 11 speed	SRAM GX Eagle 12 speed	SRAM X01 Eagle
Brakes	SRAM Level T	SRAM Level TL	SRAM Level TLM
Rotors	Avid Centerline - 160mm	Avid Centerline - 160mm	Avid Centerline - 160mm
Crankset	Race Face Aeffect 32t - 170mm (S), 175mm (M-XL)	SRAM GX Eagle 32t - 170mm (S), 175mm (M-XL)	SRAM X1 Eagle Carbon 32t - 170mm (S), 175mm (M-XL)
Cassette	SRAM XG1150 CS 10-42t	SRAM XG1275 Eagle 10-50t	SRAM XG1295 Eagle 10-50t
Chain	SRAM PC1110	SRAM GX Eagle 12 speed	SRAM X01 Eagle 12 speed
Handlebar	Race Face Evolve Flat Bar 31.8x720mm	Race Face Evolve Flat Bar 31.8x720mm	Santa Cruz XC Carbon - 31.8 x 750mm
Stem	Race Face Ride Stem	Race Face Ride Stem	Race Face Turbine Basic
Grips	Santa Cruz Palmdale Grips - Black	Santa Cruz Palmdale Grips - Black	Santa Cruz Palmdale Grips - Black
Headset	Cane Creek 10 IS Integrated Headset	Cane Creek 40 IS Integrated Headset	Cane Creek 40 IS Integrated Headset
Seatpost	Race Face Ride	Race Face Ride	Easton EC70 Zero 27.2
Saddle	WTB Volt Race	WTB Volt Race	WTB Silverado Pro
Front Tire	Maxxis Crossmark DC EXO TR 27.5x2.1"	Maxxis Crossmark DC EXO TR 27.5x2.1"	Maxxis Ikon TR EXO - 27.5x2.2"
Rear Tire	Maxxis Crossmark DC EXO TR 27.5x2.1"	Maxxis Crossmark DC EXO TR 27.5x2.1"	Maxxis Ikon TR EXO - 27.5x2.2"
Tubes/Sealant	Stan's Sealant	Stan's Sealant	Stan's Sealant
Front Hub	Novatec D711 - 15x110mm	Novatec D641 - 15x110mm	DT 350 - 15x110mm, 28h, Torque Cap
Rear Hub	Novatec D462 - 12x142mm (XD)	Novatec D642 - 12x142mm (XD)	DT 350 TA - 12x142mm, 28h (XD)
Rim	WTB STP i19 TCS	Race Face AR 24 - 32h	Race Face ARC 24 - 28h
Spokes	DT Competition	DT Competition	DT Competition
Prezzo telaio	-	-	€2.199,00
Prezzo bici	€3.399,00	€3.799,00	€5.799,00

HIGHBALL 29

La versione con ruote da 29" è quella più indicata per un impiego Xc racing, specie se in abbinamento alle nuove ruote Santa Cruz Reserve con cerchio in fibra di carbonio. L'angolo di sterzo da 70,5° e il tubo superiore più lungo parlano chiaro: questa bici si guida come una moderna Mtb da Xc racing. E nel suo Dna, guidandola, non mancherà di farsi vedere la sua indole ludica, ossia il tratto in comune a tutte le altre Santa Cruz. Il peso del telaio parte da 1,19 Kg, cioè tanta sostanza e tanto supporto per la vostra potenza. Ora non avete scuse...

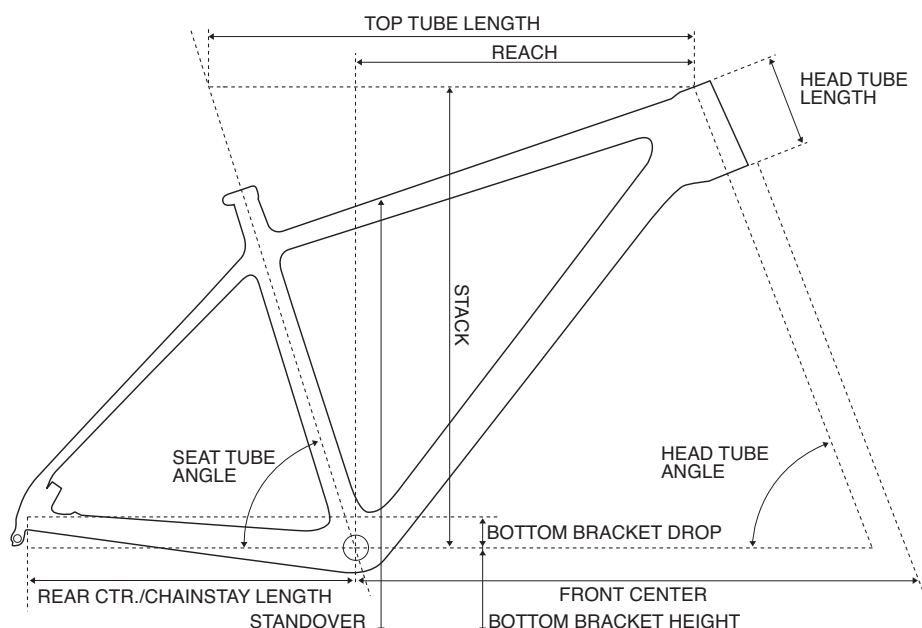

GEOMETRIA

	M	L	XL	XXL
Reach	406mm	429mm	450mm	473mm
Stack	614mm	623mm	632mm	642mm
Head Tube Angle	70.5°	70.5°	70.5°	70.5°
Head Tube Length	90mm	100mm	110mm	120mm
Seat Tube Angle	72.5°	72.5°	72.5°	72.5°
Seat Tube Length	432mm	476mm	533mm	571mm
Rear Center	430mm	430mm	430mm	430mm
Front Center	649mm	670mm	700mm	725mm
BB Height	314mm	314mm	314mm	314mm
BB Drop	56mm	56mm	56mm	56mm
Top Tube Length	600mm	625mm	650mm	675mm
Standover	734mm	756mm	801mm	836mm

CARATTERISTICHE

- Hardtail concepita per forcella da 100 mm di escursione.
- Versione per ruote da 29 pollici.
- Opzione cerchi Santa Cruz Reserve 25 in carbonio sulle bici CC.
- Disponibile in carbonio CC, carbonio C e alluminio.
- Garanzia a vita per il telaio.
- Perfetta per: gare XC, pedalata su sentieri regolari.
- A suo agio su: dal cross country al trail fluido.
- Taglie: M, L, XL, XXL.
- Peso: 9,74-12,47 kg.
- Solo telaio a partire da: 1,19 kg.
- Colore: Gloss Grey/Red - Matte Black/White.





	HIGHBALL 29 C R	HIGHBALL 29 C S	HIGHBALL 29 CC X01	HIGHBALL 29 CC X01 RESERVE
Frame	Carbon C 29" Hardtail	Carbon C 29" Hardtail	Carbon CC 29" Hardtail	Carbon CC 29" Hardtail
Shock	N/A	N/A	N/A	N/A
Fork	RockShox Reba RL 100	RockShox SID RL 100	RockShox SID RLC 100	RockShox SID RLC 100
R. Derailleur	SRAM NX 11 speed Long Cage	SRAM GX Eagle 12 speed	SRAM X01 Eagle 12 speed	SRAM X01 Eagle 12 speed
F. Derailleur	N/A	N/A	N/A	N/A
Chainguide	N/A	N/A	N/A	N/A
Shifters	SRAM NX 11 speed	SRAM GX Eagle 12 speed	SRAM X01 Eagle	SRAM X01 Eagle
Brakes	SRAM Level T	SRAM Level TL	SRAM Level TLM	SRAM Level TLM
Rotors	Avid Centerline - 160mm	Avid Centerline - 160mm	Avid Centerline - 160mm	Avid Centerline - 160mm
Crankset	Race Face Aeffect 32t - 175mm	SRAM GX Eagle 32t - 175mm	SRAM X1 Eagle Carbon 32t - 175mm	SRAM X1 Eagle Carbon 32t - 175mm
Cassette	SRAM XG1150 CS 10-42t	SRAM XG1275 Eagle 10-50t	SRAM XG1295 Eagle 10-50t	SRAM XG1295 Eagle 10-50t
Chain	SRAM PC1110	SRAM GX Eagle 12 speed	SRAM X01 Eagle 12 speed	SRAM X01 Eagle 12 speed
Handlebar	Race Face Evolve Flat Bar 31.8x720mm	Race Face Evolve Flat Bar 31.8x720mm	Santa Cruz XC Carbon - 31.8 x 750mm	Santa Cruz XC Carbon - 31.8 x 750mm
Stem	Race Face Ride Stem	Race Face Ride Stem	Race Face Turbine Basic	Race Face Turbine Basic
Grips	Santa Cruz Palmdale Grips - Black	Santa Cruz Palmdale Grips - Black	Santa Cruz Palmdale Grips - Black	Santa Cruz Palmdale Grips - Black
Headset	Cane Creek 10 IS Integrated Headset	Cane Creek 40 IS Integrated Headset	Cane Creek 40 IS Integrated Headset	Cane Creek 40 IS Integrated Headset
Seatpost	Race Face Ride	Race Face Ride	Easton EC70 Zero 27.2	Easton EC70 Zero 27.2
Saddle	WTB Volt Race	WTB Volt Race	WTB Silverado Pro	WTB Silverado Pro
Front Tire	Maxxis Crossmark DC EXO TR - 29x2.1"	Maxxis Crossmark DC EXO TR - 29x2.1"	Maxxis Ikon TR EXO - 29x2.2"	Maxxis Ikon TR EXO - 29x2.2"
Rear Tire	Maxxis Crossmark DC EXO TR - 29x2.1"	Maxxis Crossmark DC EXO TR - 29x2.1"	Maxxis Ikon TR EXO - 29x2.2"	Maxxis Ikon TR EXO - 29x2.2"
Tubes/Sealant	Stan's Sealant	Stan's Sealant	Stan's Sealant	Stan's Sealant
Front Hub	Novatec D711 - 15x110mm	Novatec D641 - 15x110mm	DT 350 - 15x110mm, 28h, Torque Cap	DT 350 - 15x110mm, 28h, Torque Cap
Rear Hub	Novatec D462 - 12x142mm (XD)	Novatec D642 - 12x142mm (XD)	DT 350 TA - 12x142mm, 28h (XD)	DT 350 TA - 12x142mm, 28h (XD)
Rim	WTB STP i19 TCS	Race Face AR 24 - 32h	Race Face ARC 24 - 28h	Santa Cruz Reserve 25 Carbon - 28h
Spokes	DT Competition	DT Competition	DT Competition	DT Competition Race
Prezzo telaio	-	-	€2.199,00	€2.199,00
Prezzo bici	€3.399,00	€3.799,00	€5.799,00	€6.999,00

JACKAL

La Jackal è una bici che fa quello che dice, senza raccontare palle: pump track, dirt jumping, guerriglia urbana. È venduta come solo telaio e monta le vecchie gomme da 26". Costruiti per durare per sempre, questi telai sono in grado di sopportare più abusi di quanto possiate immaginare e continuare a pesare meno di 2,2 kg. Uno yoke simmetrico permette l'utilizzo di un carro solido come roccia e molto corto. E per chi vuole spingersi oltre nell'anarchia, i dropout posteriori scorrevoli, unici nel loro genere, consentono un setup single speed o geared.

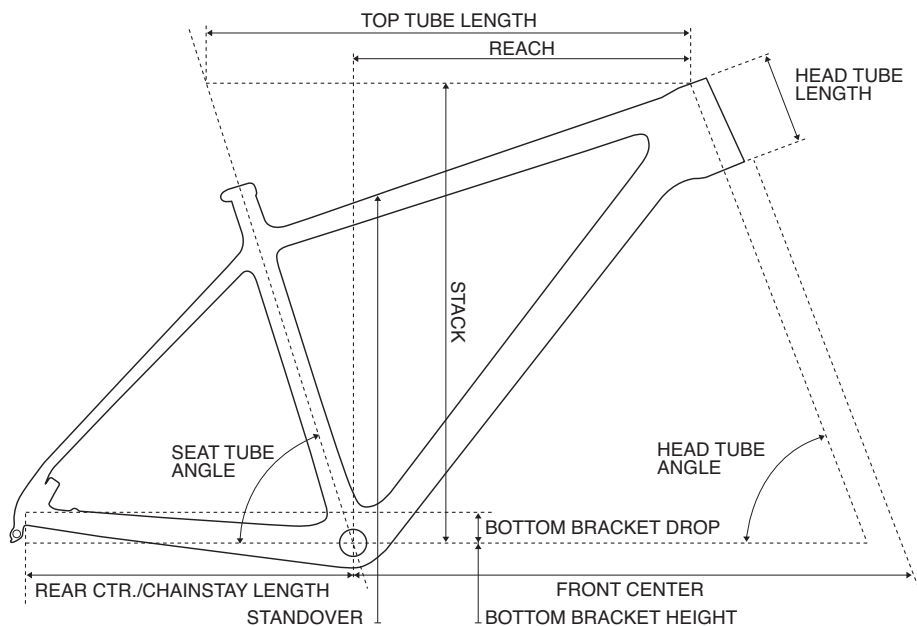

GEOMETRIA

	M	L
Reach	392mm	417mm
Stack	563mm	563mm
Head Tube Angle	68.7°	68.7°
Head Tube Length	115mm	115mm
Seat Tube Angle	73°	73°
Seat Tube Length	340mm	340mm
Rear Center	387-407mm	387-407mm
Front Center	646mm	672mm
BB Height	324mm	324mm
BB Drop	16mm	16mm
Top Tube Length	572mm	596mm
Standover	630mm	627mm

CARATTERISTICHE

- Hardtail costruito per forcelle da 100-140 mm.
- Si monta su gomme OG da 26".
- Solo telaio, la bici la create voi.
- Disponibile solo in alluminio.
- Garanzia a vita per il telaio.
- Perfetta per: voli, salti e pump track.
- A suo agio su: dirt jump, pump track e guida urbana.
- Taglie: M, L.
- Peso solo telaio: 2,26 kg.
- Colore: Black Metallic Silver.
- **Prezzo solo telaio: 1.099 €**





STIGMATA

Costruita interamente come una ciclocross da corsa, la Stigmata, dotata di freno a disco, è ugualmente a suo agio su strade sterrate e sentieri più regolari. E se desiderate una bici da asfalto che trasmetta le sensazioni di una mountain bike aggiungete una coppia di gomme slick e via. Favorita sui circuiti di gara di ciclocross, la Stigmata sfoggia un BB basso e uno standover generoso che ne rendono sicuri manovrabilità e sollevamento. I carri ampi consentono di montare gomme fino a 41 mm di larghezza per una maggiore morbidezza.

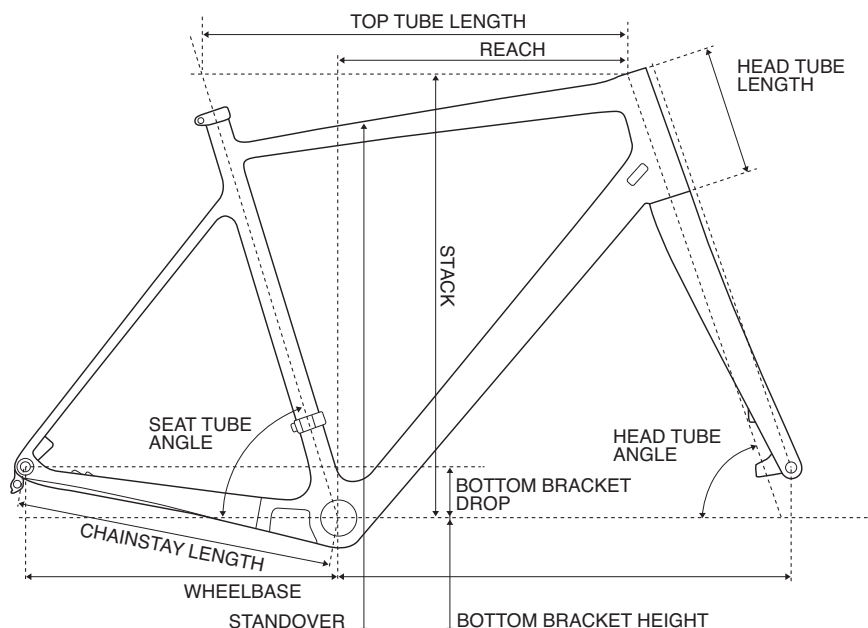

GEOMETRIA

	52	54	56	58	60
Reach	378mm	383mm	388mm	392mm	408mm
Stack	545mm	566mm	582mm	598mm	613mm
Head Tube Angle	71°	71.5°	72°	72.5°	72.5°
Head Tube Length	125mm	145mm	160mm	175mm	190mm
Seat Tube Angle	74.5°	74°	73.5°	73°	73°
Seat Tube Length	530mm	545mm	560mm	570mm	590mm
Rear Center	425mm	425mm	425mm	425mm	425mm
Front Center	588mm	594mm	599mm	604mm	624mm
BB Height	271mm	271mm	271mm	271mm	271mm
BB Drop	69mm	69mm	69mm	69mm	69mm
Top Tube Length	530mm	545mm	560mm	575mm	595mm
Standover	770mm	786mm	794mm	802mm	819mm

CARATTERISTICHE

- Il telaio 700c CX ospita gomme fino a 41 mm di sezione.
- Compatibile con dischi da 140 e 160 mm di diametro.
- Disponibile in carbonio CC.
- Garanzia a vita per telaio e forcella.
- Perfetta per: ciclocross racing e ghiaia.
- A suo agio con: circuiti di CX, Fire Road e percorsi regolari.
- Taglie: 52, 54, 56, 58, 60 cm.
- Peso: 8,02 kg.
- Peso solo telaio: 1,01 kg.
- Colore: Gloss Fog/Copper - Gloss Sunset/Gold.





**STIGMATA CC
RIVAL 700c**
**STIGMATA CC
CX1 700c**
**STIGMATA CC
ULTEGRA 700c**

	STIGMATA CC RIVAL 700c	STIGMATA CC CX1 700c	STIGMATA CC ULTEGRA 700c
Frame	Carbon CC 700c Cyclocross	Carbon CC 700c Cyclocross	Carbon CC 700c Cyclocross
Shock	N/A	N/A	N/A
Fork	Stigmata CC Carbon	Stigmata CC Carbon	Stigmata CC Carbon
R. Derailleur	SRAM Rival 22 Mid Cage	SRAM Force CX1 Long Cage	Shimano Ultegra 11sp
F. Derailleur	SRAM Rival 11 speed Braze On	N/A	Shimano Ultegra 11sp
Chainguide	N/A	N/A	N/A
Shifters	SRAM Rival 22	SRAM Force CX1	Shimano Ultegra 8020
Brakes	SRAM Rival	SRAM Force	Shimano Ultegra 785
Rotors	Avid Centerline - 160mm	SRAM CLX Center Lock - 160mm	Shimano RT-900 Centerlock - 140mm
Crankset	SRAM Rival 22 50/34	Easton EC90 SL 42t	Shimano Ultegra 11 speed 50/34
Cassette	SRAM Rival PG1130 11-32t	SRAM PG1170 11-36t	Shimano Ultegra 6800 11-34t
Chain	SRAM PC1170	SRAM PC1170	Shimano SLX M7000
Handlebar	Zipp Service Course 42cm (52), 44cm (54-60)	Easton EA70 RB - 42cm (52), 44cm (54-56), 46cm (58-60)	Easton EA70 RB - 42cm (52), 44cm (54-56), 46cm (58-60)
Stem	Zipp Service Course - 90mm (52), 100mm (54), 110mm (56-58), 120mm (60)	Zipp Service Course - 90mm (52), 100mm (54), 110mm (56-58), 120mm (60)	Zipp Service Course - 90mm (52), 100mm (54), 110mm (56-58), 120mm (60)
Grips	Santa Cruz Perforated	Santa Cruz Perforated	Santa Cruz Perforated
Headset	Cane Creek 110 IS Integrated Headset	Cane Creek 110 IS Integrated Headset	Cane Creek 110 IS Integrated Headset
Seatpost	Zipp Service Course 27.2	Easton EC70 Zero 27.2	Easton EC70 Zero 27.2
Saddle	WTB Silverado Road NiCro	WTB Silverado Road NiCro	WTB Silverado Road NiCro
Front Tire	Maxxis Rambler - 700x40c	WTB Cross Boss - 700x35c	Maxxis Rambler - 700x40c
Rear Tire	Maxxis Rambler - 700x40c	WTB Cross Boss - 700x35c	Maxxis Rambler - 700x40c
Tubes/Sealant	Stan's Sealant	Stan's Sealant	Stan's Sealant
Front Hub	DT 370 - 15x100mm, 28h	DT 350 Centerlock - 15x100mm, 28h	DT 350 Centerlock - 15x100mm, 28h
Rear Hub	DT 370 - 12x142mm, 28h	DT 350 Centerlock - 12x142mm, 28h	DT 350 Centerlock - 12x142mm, 28h
Rim	WTB Asym i19p	DT XR 361 Asym - 28h	DT XR 361 Asym - 28h
Spokes	DT Competition	DT Competition Race	DT Competition Race
Prezzo telaio	€2.499,00	€2.499,00	€2.499,00
Prezzo bici	€4.199,00	€4.999,00	€5.299,00

CHAMELEON

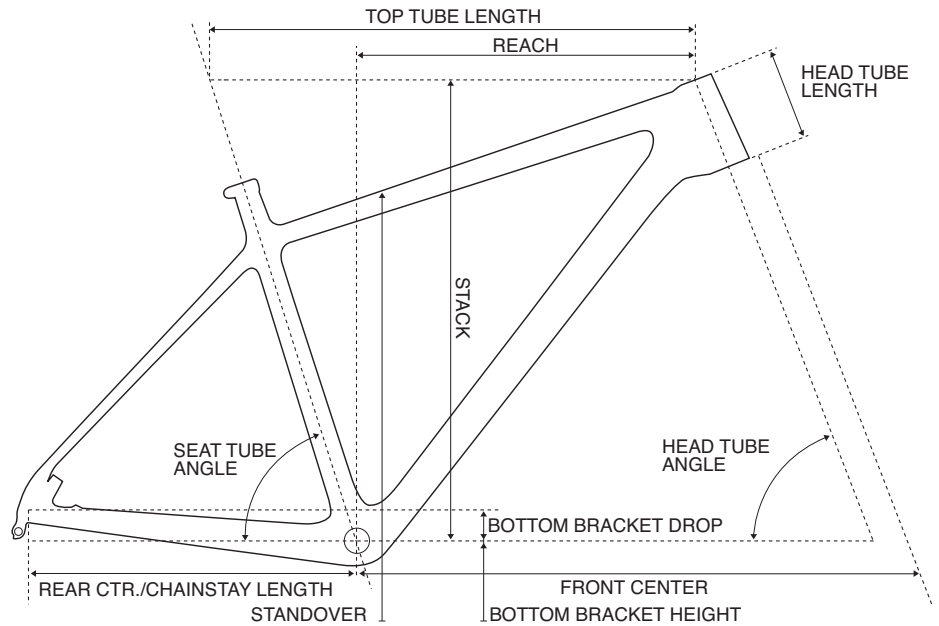
Come suggerisce il nome, la Chameleon è una bici che può cambiare per adattarsi al suo ambiente. Con la possibilità di montare gomme sia da 29" sia da 27,5"+, con i forcellini sostituibili questa versatile hardtail può trasformarsi in single speed o in geared bike e diventare un aggressivo destriero o una robusta bestia da soma o qualsiasi altra cosa ci sia nel mezzo. In base all'allestimento e al manico del biker, la Chameleon è per un'ampia gamma di terreni: da trail poco aggressivi alle jump line dei bike park fino all'uso all-around.



GEOMETRIA

	S (27.5+/29)	M (27.5+/29)	L (27.5+/29)	XL (27.5+/29)
Reach	415 / 412mm	440 / 437mm	460 / 457mm	490 / 487mm
Stack	615 / 617mm	615 / 617mm	614 / 617mm	624 / 627mm
Head Tube Angle	67.5 / 67.3°	67.5 / 67.3°	67.5 / 67.3°	67.5 / 67.3°
Head Tube Length	100 / 100mm	100 / 100mm	100 / 100mm	110 / 110mm
Seat Tube Angle	73 / 72.8°	73 / 72.8°	73 / 72.8°	73 / 72.8°
Seat Tube Length	390 / 390mm	420 / 420mm	450 / 450mm	490 / 490mm
Rear Center	415-430mm	415-430mm	415-430mm	415-430mm
Front Center	704 / 703mm	729 / 728mm	749 / 748mm	783 / 782mm
BB Height	315 / 315mm	315 / 315mm	315 / 315mm	315 / 315mm
BB Drop	50 / 55mm	50 / 55mm	50 / 55mm	50 / 55mm
Top Tube Length	596 / 601mm	621 / 626mm	642 / 649mm	674 / 682mm
Standover	689 / 689mm	705 / 696mm	721 / 721mm	739 / 740mm

CARATTERISTICHE

- Hardtail costruita su una forcella con escursione da 120 mm.
- Pneumatici convertibili tra 29 e 27,5+.
- Dropout intercambiabili single speed o geared.
- Disponibile solo in alluminio.
- Garanzia a vita per il telaio.
- Perfetta per: trail moderato e guida avventurosa.
- A suo agio su: dal cross country al trail fluido.
- Taglie: S, M, L, XL.
- Peso: 12,70-12,84 kg.
- Solo telaio a partire da: 2,12 kg.
- Colore: Olive green.





CHAMELEON A
D 27+

CHAMELEON A
D 29

Frame	Aluminum 29/27+ Hardtail	Aluminum 29/27+ Hardtail
Shock	N/A	N/A
Fork	RockShox Recon RL 120	RockShox Recon RL 120
R. Derailleur	SRAM NX 11 speed Long Cage	SRAM NX 11 speed Long Cage
F. Derailleur	N/A	N/A
Chainguide	N/A	N/A
Shifters	SRAM NX 11 speed	SRAM NX 11 speed
Brakes	SRAM Level	SRAM Level
Rotors	Avid Centerline - 180mm	Avid Centerline - 180mm
Crankset	Race Face Aeffect 30t - 170mm (S), 175mm (M-XL)	Race Face Aeffect 30t - 170mm (S), 175mm (M-XL)
Cassette	SRAM PG1130 11-42t	SRAM PG1130 11-42t
Chain	SRAM PC1110	SRAM PC1110
Handlebar	Race Face Ride - 35x760mm	Race Face Ride - 35x760mm
Stem	Race Face Ride - 50mm	Race Face Ride - 50mm
Grips	Santa Cruz Palmdale Grips - Black	Santa Cruz Palmdale Grips - Black
Headset	Cane Creek 10 IS Integrated Headset	Cane Creek 10 IS Integrated Headset
Seatpost	Race Face Ride	Race Face Ride
Saddle	WTB Volt Sport	WTB Volt Sport
Front Tire	WTB Ranger Light/High Grip 27.5x3.0"	Maxxis Crossmark II DC EXO TR 29X2.25"
Rear Tire	WTB Ranger Light/High Grip 27.5x3.0"	Maxxis Minion DHF EXO TR - 29x2.3"
 Tubes/Sealant	Stan's Sealant	Stan's Sealant
Front Hub	Novatec D711 - 15x110mm	Novatec D711 - 15x110mm
Rear Hub	Novatec D462 - 12x148mm (HG)	Novatec D462 - 12x148mm (HG)
Rim	Race Face AR 40 - 32h	WTB ST i23 TCS
Spokes	DT Competition	DT Competition
Prezzo telaio	€999,00	€999,00
Prezzo bici	€2.399,00	€2.399,00

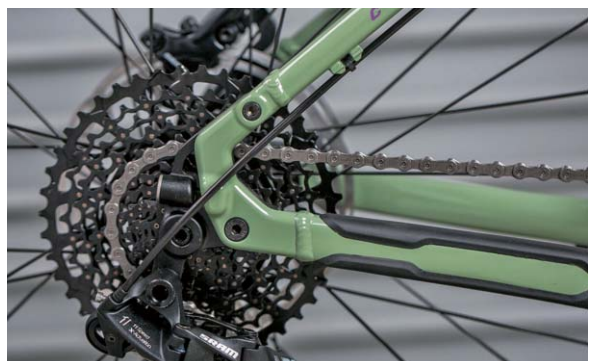

CHAMELEON A
R 27+CHAMELEON A
R 29

	CHAMELEON A R 27+	CHAMELEON A R 29
Frame	Aluminum 29/27+ Hardtail	Aluminum 29/27+ Hardtail
Shock	N/A	N/A
Fork	FOX Rhythm 34 120	FOX Rhythm 34 120
R. Derailleur	SRAM NX 11 speed Long Cage	SRAM NX 11 speed Long Cage
F. Derailleur	N/A	N/A
Chainguide	N/A	N/A
Shifters	SRAM NX 11 speed	SRAM NX 11 speed
Brakes	SRAM Level T	SRAM Level T
Rotors	Avid Centerline - 180mm	Avid Centerline - 180mm
Crankset	Race Face Aeffect 30t - 170mm (S), 175mm (M-XL)	Race Face Aeffect 30t - 170mm (S), 175mm (M-XL)
Cassette	SRAM XG1150 CS 10-42T	SRAM XG1150 CS 10-42T
Chain	SRAM PC1110	SRAM PC1110
Handlebar	Race Face Ride - 35x760mm	Race Face Ride - 35x760mm
Stem	Race Face Ride - 50mm	Race Face Ride - 50mm
Grips	Santa Cruz Palmdale Grips - Black	Santa Cruz Palmdale Grips - Black
Headset	Cane Creek 10 IS Integrated Headset	Cane Creek 10 IS Integrated Headset
Seatpost	Race Face Aeffect - 31.6x125mm (S-M), 150mm (L-XL)	Race Face Aeffect - 31.6x125mm (S-M), 150mm (L-XL)
Saddle	WTB Volt Race	WTB Volt Race
Front Tire	WTB Ranger Light/High Grip 27.5x3.0"	Maxxis Minion DHF EXO TR - 29x2.3"
Rear Tire	WTB Ranger Light/High Grip 27.5x3.0"	Maxxis Crossmark II DC EXO TR 29x2.25"
Tubes/Sealant	Stan's Sealant	Stan's Sealant
Front Hub	Novatec D711 - 15x110mm	Novatec D711 - 15x110mm
Rear Hub	Novatec D462 - 12x148mm (XD)	Novatec D462 - 12x148mm (XD)
Rim	Race Face AR 40 - 32h	WTB ST i23 TCS
Spokes	DT Competition	DT Competition
Prezzo telaio	€999,00	€999,00
Prezzo bici	€2.999,00	€2.999,00

*Un dettaglio
della Santa Cruz
Hightower Lt*







Non è più lei eppure è ancora di più lei.

Non è più lei, eppure è ancora di più lei.
Sì, se ti fermi all'estetica è tutta un'altra Nomad e quasi sembra che Santa Cruz abbia cercato di "rianimare" la Nomad usando la V10.
Perché la sospensione è praticamente identica.

Ma, caro amico da chiacchiera del bar, ti sbagli, e anche di grosso.

La Nomad è sempre lei, quella bestia rara capace di fare due cose impossibili come andare bene in salita e andare ancora meglio in discesa, è solo più moderna e ha sempre



stesso scopo: stupire.

Lo fece la prima nel 2005 e lo sta facendo già anche questa nel 2017.

E, allora, preparati un paio di risposte da dare alla faticata, sciocca, rompi-cazzo e ovvia domanda che ti faranno quando ti vedranno girare con lei.

«Con questi soldi compravi una XXXXXXXX (un qualunque marchio di bici che vende online) e te la montavi da paura: ma perché ancora insisti con Santa Cruz?»

Capito il tono?

Adesso fregati le mani e scegli una delle risposte che stai per leggere oppure, se proprio ti fanno incazzare, apri i boccaporti e sparagli contro tutte queste risposte:

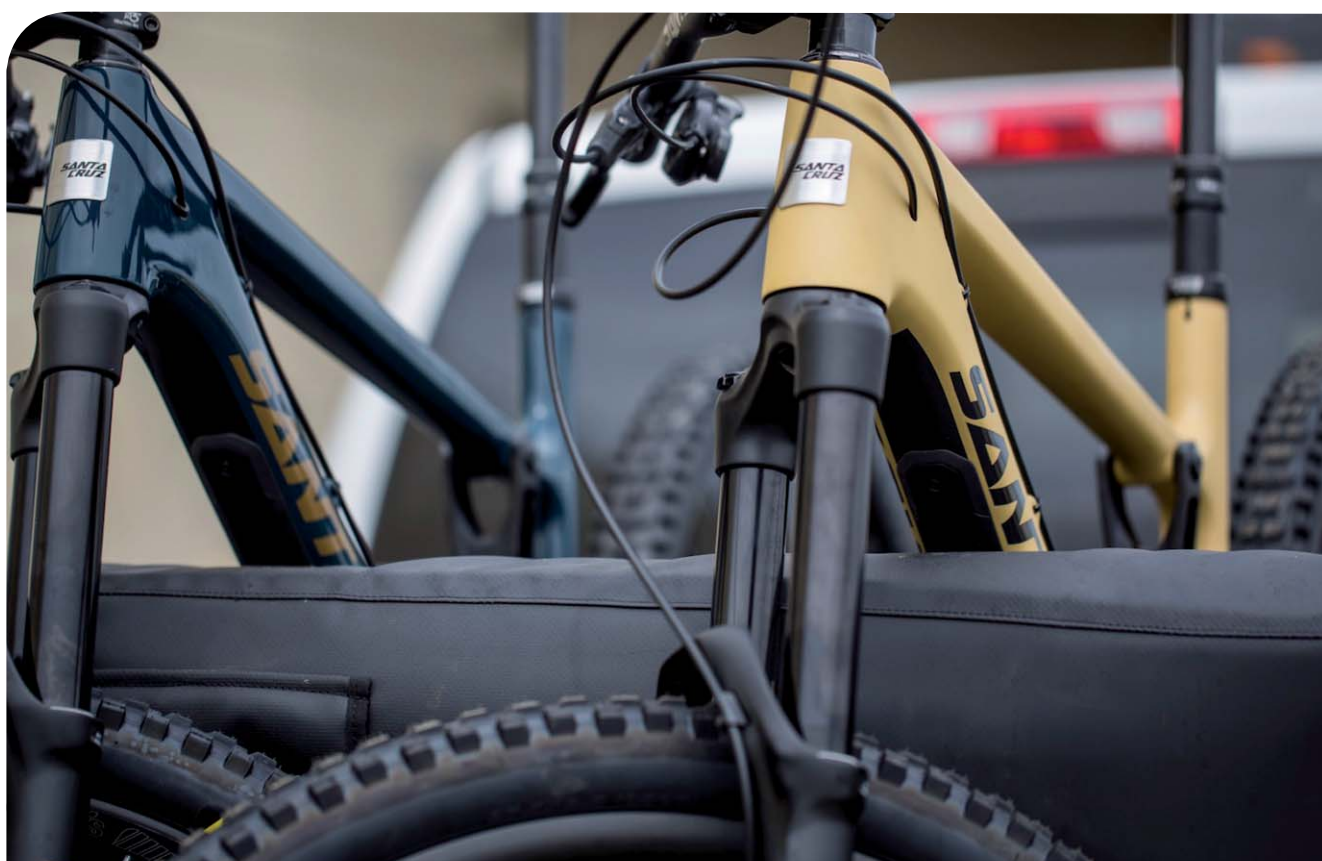
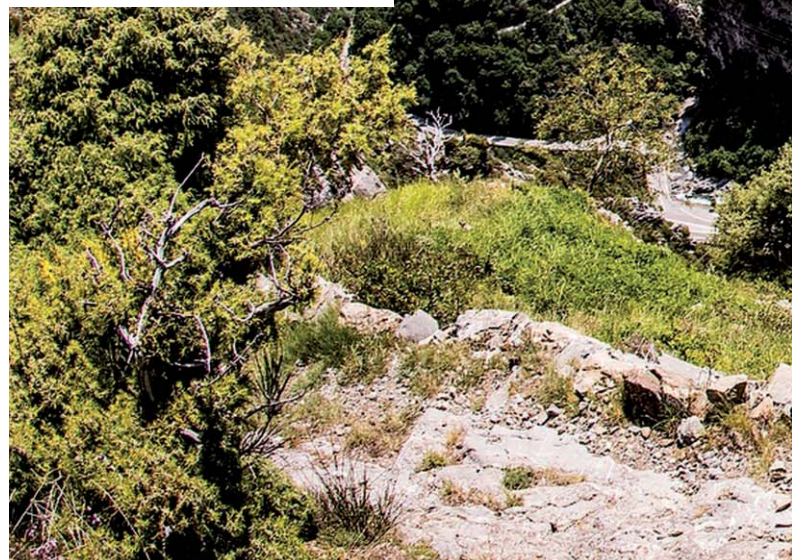

«Non cedo ai “vorrei ma non posso” e mi prendo quello che mi piace. E che piace pure agli altri...»



- Senti, quando ho il tempo per divertirmi, mi diverto sul serio. Aspetto, tiro la cinghia se serve, non cedo ai “vorrei ma non posso” e mi prendo quello che mi piace. E che piace pure agli altri, così la rivendo meglio. Semmai la rivenderò...

- La fibra di carbonio Santa Cruz è di un altro livello, ma costa come gli altri marchi top

- Sono curioso di vedere la faccia che farai quando scoprirai su cosa XXXXXX (cioè il marchio di bici vendute online) ha risparmiato per riuscire a fartela pagare così poco.

- Perché sono molto religioso e credo nella Santa Croce

- Per far girare la testa e le palle agli altri

Se n'è andato quello con la bici XXXXX?

Poco importa, adesso ci sei solo tu e i prodigi di questa belva da polvere, rocce e velocità folli.

Inizia piano, dalle del lei, cerca di capirla, perché sulle

prima può lasciare interdetti. Non è una bici facilissima a prima vista, perché è pensata per andare fortissimo con gente fortissima.

E se non sei fortissimo ti bastano un paio di km per capirla.

Come mi devo mettere in sella?

Quanto posso lasciare i freni?

Quanto posso osare con la velocità?

Ecco, a queste domande non c'è una risposta preconfezionata, ma c'è solo la tua esperienza.

La tua velocità.

E il tuo piacere di guida.

La Santa Cruz Nomad piace a tutti e se la prova quel pedalone del tuo amico che pensa solo ad andare forte in salita diventa pazzo.

Anzi, diventa un nomade errante delle montagne.

Però tu lo sai, sai che questa è roba pesante e sai che la prima volta serve rispetto.

Come con una moto da 1000.

E ora sei qui, ce l'hai davanti e adesso te ne puoi sbattere di tutto, caro il mio nomade.

MONDRAKER



MONDRAKER



★ d s b ★

SEMPLICEMENTE BICI



Mondraker costruisce mountain bike di alte prestazioni, per le gare e per le uscite della domenica.

Non ha altri scopi.

E i mezzi che utilizza sono creatività, innovazione e materiali di qualità. Il marchio spagnolo è stato l'artefice di uno dei cambiamenti più importanti negli ultimi 10 anni grazie alla Forward Geometry che ha rivoluzionato il modo di intendere la posizione in sella. E ora, con il mondo e-Bike sempre più popolare, ha lanciato una proposta dannatamente efficace: la e-Crusher, ossia la sua prima e-Bike full con telaio full carbon. Girate pagina per scoprire l'universo Mondraker.

E-CRUSHER +

Le tubazioni in fibra di carbonio con profili Stealth, la sospensione Zero, la Forward Geometry, il motore Shimano Steps e un equipaggiamento adeguato al peso e alle capacità della bici rendono la Mondraker e-Crusher una delle e-Bike più aggressive, capaci e affascinanti sulla piazza.

150 mm di escursione sulla ruota posteriore permettono numeri impressionanti se abbinata a gomme Maxxis Minion Dhf e High Roller da 2,8".

Insomma, una e-Bike con ruote Plus pensata per chi vuole guidare davvero in discesa...

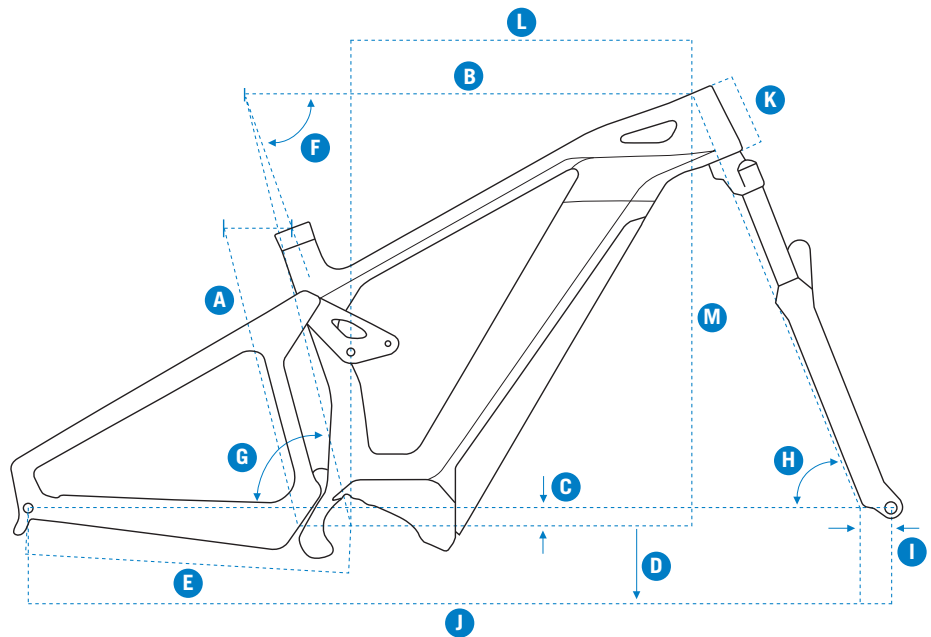

GEOMETRIA

	S	M	L	XL
A Seat Tube Length	380mm	420mm	470mm	500mm
B Top Tube Length	608mm	636mm	658mm	684mm
C Bottom Bracket Drop	-18mm	-18mm	-18mm	-18mm
D Bottom Bracket Height	342mm	342mm	342mm	342mm
E Chainstay Length	450mm	450mm	450mm	450mm
F Seat Tube Angle, Actual	70°	70°	70°	70°
G Seat Tube Angle, Effective	74.5°	74.5°	74.5°	74.5°
H Head Tube Angle	66.5°	66.5°	66.5°	66.5°
I Fork Offset	51mm	51mm	51mm	51mm
J Wheelbase	1201mm	1226mm	1252mm	1281mm
K Head Tube Length	100mm	100mm	115mm	130mm
L Reach	441mm	466mm	486mm	506mm
M Stack	609mm	609mm	623mm	637mm

CARATTERISTICHE

- 150 mm di escursione.
- Pneumatici da 27,5" Plus.
- Telaio in fibra di carbonio Stealth.
- Mondraker Forward Geometry.
- Motore Shimano Steps con batteria integrata Shimano da 504 Wh.
- Battute mozzi Boost.
- Cuscinetti sospensione sigillati MAX.
- Garanzia a vita sul telaio.
- Taglie: S, M, L, XL.
- Peso: da 22,2 a 22,8 kg.
- Colore: Graphite-Vibrant Blue (e-Crusher Carbon RR+), Graphite-Orange (e-Crusher Carbon R+).



E-CRUSHER CARBON RR+

Frame	e-Crusher 27,5+ Stealth Full Carbon Structure
Shock	Fox Float DPX2 LV EVOL Factory
Fork	Fox 36 27,5+ Float FIT HSC LSC Evol Factory 160 mm
Headset	Onoff Saturn Tapered for 1-1/8" -> 1/5"
R. Derailleur	Shimano XTR RD-M9000GS
Chain	Shimano CN-HG6011
Shifters	Shimano XTR SML9000R, Rapidfire Plus, 2 Way release
Brakes	Shimano Saint M820 203mm, 4-piston caliper,
Rotors	Shimano RT86 6 bolts rotor ICE tech.
Crankset	Shimano FC-E8050 hollowtech 34T
Cassette	Shimano XT CS-M8000 11-46T 11s.
Handlebar	Onoff Stoic Carbon 0.5 780mm 35mm barbore
Stem	Onoff Stoic FG 30mm. Forged 6061 alloy, 35mm barbore
Grips	Onoff Diamond, 1lock-on, 130mm
Seatpost	Fox Transfer Performance Elite internal 31.6mm, internal hose guide
Saddle	Fizik Gobi M5 VS K:IUM
Front Tire	Maxxis Minion DHF 27,5x2.8", tubeless ready, Dual compound, Exo, 60TPI
Rear Tire	High Roller 27 11,5x2.8, tubeless ready, Dual compound, Exo, 60TPI
Tubes/Sealant	-
Front Hub	Mavic 15X110mm
Rear Hub	Mavic 12x148mm Instant Drive 360 alloy, sealed cartridge bearings
Rim	Mavic E XA Elite 40mm
Spokes	stainless double butted
Weight	22,2 Kg
Prezzo bici	€8.999,00





E-CRUSHER CARBON R+

Frame	e-Crusher 27,5+ Stealth Full Carbon Structure
Shock	RockShox Superdeluxe R Debonair
Fork	RockShox Yari 27,5 RC 160mm
Headset	Onoff Saturn Tapered for 1-1/8" -> 1/5"
R. Derailleur	Shimano XT RD-M8000SGS
Chain	Shimano CN-HG6011
Shifters	Shimano XT SL-M8000R
Brakes	Sram Guide RE
Rotors	Sram 200 mm Centerline 6 bolts
Crankset	Shimano FC-E8000 34T
Cassette	Sunrace CSMCS8 11-46T 11s
Handlebar	Mondraker custom design 1.0 780mm
Stem	Onoff Stoic FG 30mm. Forged 6061 alloy, 31.8mm barbore
Grips	Onoff Diamond, 1lock-on, 130mm
Seatpost	Onoff Pija Dropper 31.6mm, internal hose guide
Saddle	Fizik Gobi M7 VS MG
Front Tire	Maxxis Minion DHF 27,5x2.8", tubeless ready, Dual compound, Exo, 60TPI
Rear Tire	High Roller 27 II, 5x2.8, tubeless ready, Dual compound, Exo, 60TPI
Tubes/Sealant	-
Front Hub	GW Pro 15X110mm
Rear Hub	GW Pro 12x148mm
Rim	NEW MDK-EP1 35 27'5+ TLR wheelset
Spokes	CN stainless
Weight	22,8 Kg
Prezzo bici	€6.999,00



E-CRAFTY +

La Mondraker e-Crafty è la versione più giocosa, agile e facile della e-Crusher.

Il telaio in lega leggera 6061 Stealth Evo, la sospensione Zero System e la Forward Geometry non devono trarre in inganno: la e-Crafty è una e-bike che sa stupire in tantissime situazioni.

Sì, la versatilità è il suo forte e in Mondraker si sono impegnati per renderla ancora più efficace.

Il motore Bosch Performance Cx e la nuova batteria integrata da 500 Wh rinnovano un'estetica già molto accattivante.

Scegli dove vuoi andare e vai.

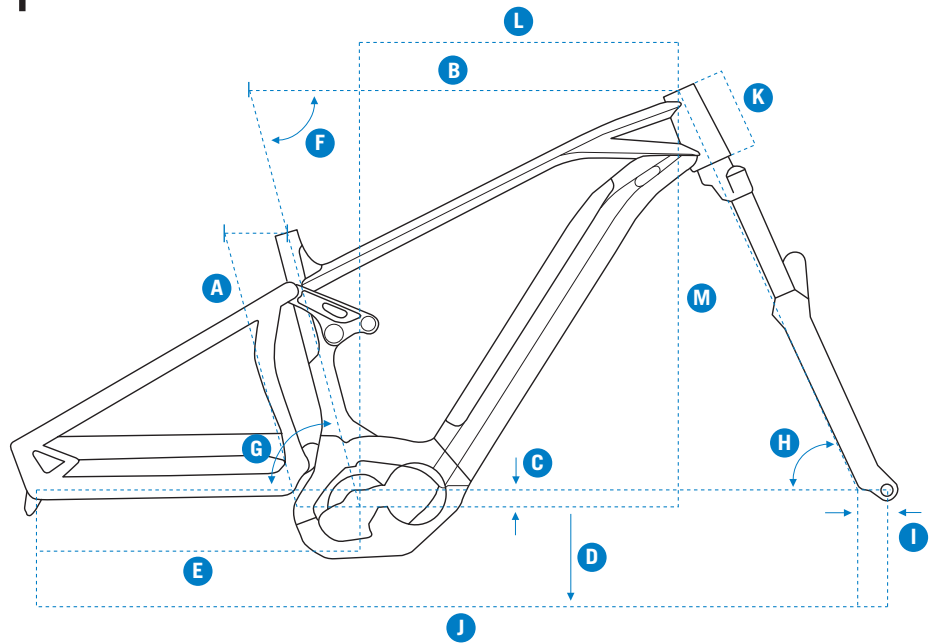

GEOMETRIA

	S	M	L	XL
A Seat Tube Length	380mm	420mm	470mm	500mm
B Top Tube Length	610mm	640mm	665mm	688mm
C Bottom Bracket Drop	-25mm	-25mm	-25mm	-25mm
D Bottom Bracket Height	330mm	330mm	330mm	330mm
E Chainstay Length	475mm	475mm	475mm	475mm
F Seat Tube Angle, Actual	75°	75°	75°	75°
G Seat Tube Angle, Effective	75°	75°	75°	75°
H Head Tube Angle	66°	66°	66°	66°
I Fork Offset	44mm	44mm	44mm	44mm
J Wheelbase	1235mm	1268mm	1296mm	1320mm
K Head Tube Length	100mm	120mm	140mm	150mm
L Reach	450mm	475mm	495mm	515mm
M Stack	600mm	618mm	636mm	645mm

CARATTERISTICHE

- 140 mm di escursione
- Pneumatici da 27,5" Plus
- Telaio in lega leggera 6061 Alloy Stealth Evo
- Mondraker Forward Geometry
- Motore Bosch Performance Cx con batteria integrata da 500 Wh
- Display Bosch Purion
- Battute mozzi Boost
- Cuscinetti sospensione sigillati MAX
- Garanzia a vita sul telaio
- Taglie: S, M, L, XL
- Colore: Flame Red-Amber Black (e-CRAFTY XR+); Graphite Black, Light Blue-Flame Red-Black (e-CRAFTY R+)





E-CRAFTY XR+

Frame	e-Crafty 27,5+ 6061 Alloy Stealth Evo
Shock	Fox Float DPX2 LV EVOL Performance
Fork	Fox 36 27,5 Float Grip Evol Performance, 160mm
Headset	Onoff Saturn Tapered for 1-1/8" -> 1/5"
R. Derailleur	Sram NX Type 3
Chain	Sram PC 1110 11s.
Shifters	Sram NX trigger
Brakes	Sram Guide RE
Rotors	Sram Centerline 200mm
Crankset	RaceFace Aeffect ebike crankset 16T
Cassette	Sram PG-1130 11-42T 11s
Handlebar	Mondraker custom design 1.0 780mm
Stem	Onoff Stoic FG 30mm. Forged 6061 alloy, 31.8mm bar bore
Grips	Onoff Diamond, 1lock-on, 130mm
Seatpost	Onoff Pija Dropper 31.6mm, internal hose guide
Saddle	Mondraker E-mtb exclusive design
Front Tire	Maxxis Minion DHF 27,5x2.8, tubeless ready, Dual compound, Exo, 60TPI
Rear Tire	High Roller 27 11,5x2.8, tubeless ready, Dual compound, Exo, 60TPI
Tubes/Sealant	-
Front Hub	DT Swiss H1900 Boost 15x110mm
Rear Hub	DT Swiss H1900 Boost 12x148mm
Rim	DT Swiss H1900 27,5 35mm Boost
Spokes	CN stainless
Weight	ND
Prezzo bici	€6.599,00





E-CRAFTY R+

Frame	e-Crafty 27,5+ 6061 Alloy Stealth Evo
Shock	RockShox Superdeluxe R Debonair
Fork	RockShox Yari 27,5" RC 150mm
Headset	Onoff Saturn Tapered for 1-1/8" -> 1/5"
R. Derailleur	Sram GX long cage
Chain	Sram PC 1031 10s.
Shifters	Sram Trigger GX, 10s
Brakes	Sram Level T
Rotors	Sram Centerline 200mm
Crankset	RaceFace Aeffect ebike crankset 16T
Cassette	Sunrace CSMCS3 11-42T 10s
Handlebar	Mondraker custom design 1.0 780mm
Stem	Onoff Stoic FG 30mm. Forged 6061 alloy, 31.8mm bar bore
Grips	Onoff Diamond, 1lock-on, 130mm
Seatpost	Onoff Pija Dropper 31.6mm, internal hose guide
Saddle	Mondraker E-mtb exclusive design
Front Tire	Maxxis Minion DHF 27,5x2.8, tubeless ready, Dual compound, Exo, 60TPI
Rear Tire	High Roller 27 11,5x2.8, tubeless ready, Dual compound, Exo, 60TPI
Tubes/Sealant	-
Front Hub	MDK Pro II 15x110mm
Rear Hub	MDK Pro II 12x148mm
Rim	NEW MDK-EP1 27,5+ Asy 35 TLR wheelset
Spokes	CN stainless
Weight	ND
Prezzo bici	€5.299,00



E-FACTOR +

È la full con pedalata assistita più facile e meno aggressiva di casa Mondraker, ma non meno raffinata. Con 120 mm di escursione, un telaio in lega leggera 6061 Stealth Side e la Forward Geometry, la Mondraker e-Factor è la e-bike full con una spiccata propensione per le escursioni e per guidare senza troppi timori grazie alle gomme 650b Plus da 2,8" di sezione. Il motore Bosch Performance Cx e la batteria PowerPack 500 permettono un'efficienza da riferimento. Non vi resta che pianificare l'uscita, accendere il motore e far lavorare la fantasia...

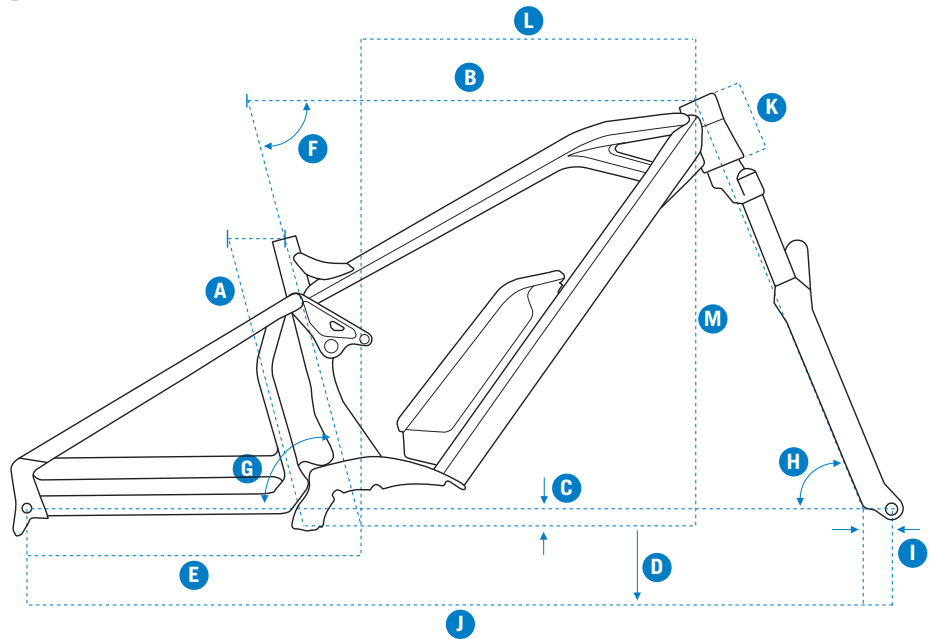

GEOMETRIA

	S	M	L	XL
A Seat Tube Length	380mm	420mm	470mm	510mm
B Top Tube Length	607mm	632mm	655mm	679mm
C Bottom Bracket Drop	-25mm	-25mm	-25mm	-25mm
D Bottom Bracket Height	330mm	330mm	330mm	330mm
E Chainstay Length	475mm	475mm	475mm	475mm
F Seat Tube Angle, Actual	75°	75°	75°	75°
G Seat Tube Angle, Effective	75°	75°	75°	75°
H Head Tube Angle	67.5°	67.5°	67.5°	67.5°
I Fork Offset	51mm	51mm	51mm	51mm
J Wheelbase	1211mm	1237mm	1262mm	1288mm
K Head Tube Length	100mm	100mm	115mm	130mm
L Reach	450mm	475mm	495mm	515mm
M Stack	586mm	586mm	600mm	614mm

CARATTERISTICHE

- 120 mm di escursione.
- Pneumatici da 27,5" Plus.
- Telaio in lega leggera 6061 Alloy Stealth Evo.
- Mondraker Forward Geometry.
- Motore Bosch Performance Cx con batteria PowerPack 500 Wh.
- Display Bosch Purion.
- Battute mozzi Boost.
- Cuscinetti sospensione sigillati MAX.
- Garanzia a vita sul telaio.
- Taglie: S, M, L, XL.
- Colore: Pearl-White-Black-Light Blue (e-Factor XR+).
- Black-Light Blue-Yellow, Orange-Black-White (e-Factor+).



E-FACTOR
XR+E-FACTOR
+

Frame	e-Factor 27,5+ 6061 Stealth Side Alloy Structure	e-Factor 27,5+ 6061 Stealth Side Alloy Structure
Shock	RockShox Monarch RT Solo Air	RockShox Monarch R Solo Air
Fork	Rockshox Revelation 27,5 RC Solo Air, 140 mm	RockShox Judy Gold 27,5+ RL Solo Air 120 mm
Headset	Onoff Saturn Tapered for 1-1/8" -> 1/5"	Onoff Saturn Tapered for 1-1/8" -> 1/5"
R. Derailleur	Sram NX Type 3	SRAM GX, long cage, Exact actuation, 10s
Chain	Sram PC 1110 11s	SRAM PC-1031 10s
Shifters	Sram Trigger NX1	Sram Trigger X5, 10s, 1:1 Actuation
Brakes	SRAM Level T	SRAM Level
Rotors	Sram Centerline 200/180 mm	Sram Centerline 200/180 mm
Crankset	Miranda Delta crankset 16T	Miranda Delta crankset 16T
Cassette	Sram PG-1130 11-42T 11s	Sunrace CSMCS3 11-42T 10s
Handlebar	Mondraker custom design 0.5 760mm	Mondraker custom design 0.5 760mm
Stem	Onoff Stoic FG 30mm. Forged 6061 alloy, 31.8mm barbore	Onoff Stoic FG 30mm. Forged 6061 alloy, 31.8mm barbore
Grips	Onoff Diamond, 1lock-on, 130mm	Onoff Diamond, 1lock-on, 130mm
Seatpost	Onoff Pija Dropper 31.6mm, internal hose guide	Onoff Pija Dropper 31.6mm, internal hose guide
Saddle	Mondraker factor XR + exclusive design	Mondraker factor + exclusive design
Front Tire	Maxxis Rekon 27,5x2.8, tubeless ready, Dual compound, Exo-protection, 60TPI	Maxxis Rekon 27,5x2.8, tubeless ready, Dual compound, Exo-protection, 60TPI
Rear Tire	Maxxis Rekon 27,5x2.8, tubeless ready, Dual compound, Exo, 60TPI	Maxxis Rekon 27,5x2.8, tubeless ready, Dual compound, Exo, 60TPI
Tubes/Sealant	-	-
Front Hub	MDK Pro II 15x110mm	MDK Pro II 15x110mm
Rear Hub	MDK Pro II 12x148mm	MDK Pro II 12x148mm
Rim	NEW MDK-EP1 27,5+ Asy 35 TLR wheelset	NEW MDK-EP1 27,5+ Asy 35 TLR wheelset
Spokes	CN stainless	CN stainless
Weight	22,4 Kg	22,3 Kg
Prezzo bici	€ 4.999,00	€ 3.999,00



E-PANZER

Le fatbike sono più vive che mai con il supporto di un motore elettrico.

Anzi, grazie alla pedalata assistita trovano tante nuove applicazioni.

Le gomme da 4,8" di sezione non spaventano più e anche i fondi più innevati e sabbiosi diventano possibili.

La Mondraker e-Panzer è la bici per chi non vuole fermarsi mai, né d'inverno, né d'estate.

Il telaio in lega leggera 6061 Xtralite ha la Forward Geometry e il motore Bosch Performance Cx con batteria da 500 Wh assicura un supporto adeguato. Ovunque.

Siete pronti a partire?

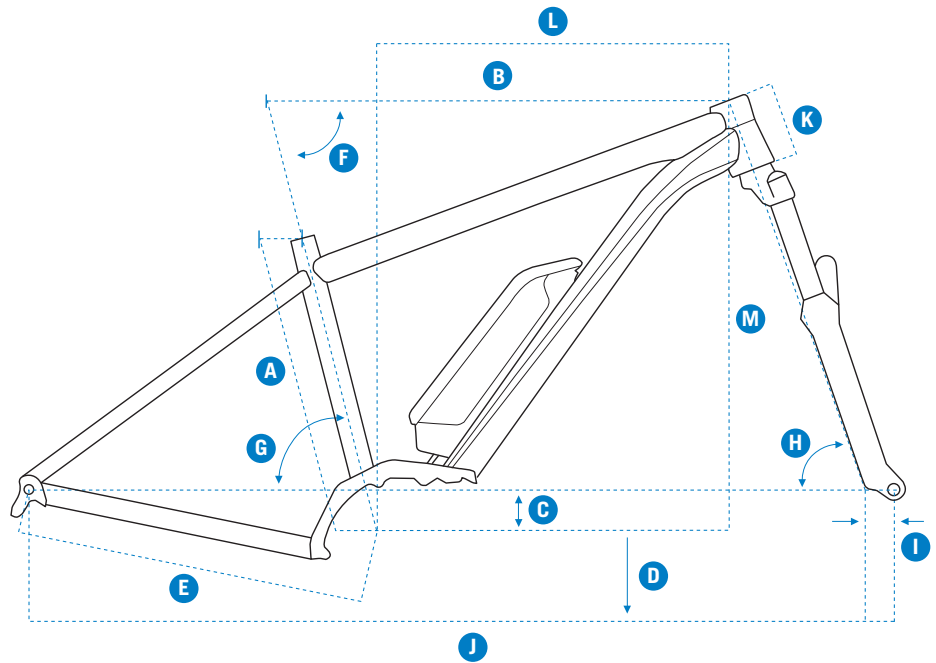

GEOMETRIA

	S	M	L	XL
A Seat Tube Length	380mm	430mm	480mm	520mm
B Top Tube Length	615mm	635mm	660mm	685mm
C Bottom Bracket Drop	-55mm	-55mm	-55mm	-55mm
D Bottom Bracket Height	315mm	315mm	315mm	315mm
E Chainstay Length	485mm	485mm	485mm	485mm
F Seat Tube Angle, Actual	73.5°	73.5°	73.5°	73.5°
G Seat Tube Angle, Effective	73.5°	73.5°	73.5°	73.5°
H Head Tube Angle	68.5°	68.5°	68.5°	68.5°
I Fork Offset	51mm	51mm	51mm	51mm
J Wheelbase	1190mm	1211mm	1237mm	1263mm
K Head Tube Length	90mm	100mm	110mm	125mm
L Reach	433mm	451mm	473mm	494mm
M Stack	614mm	623mm	632mm	646mm

CARATTERISTICHE

- Telaio in lega 6061 Xtralite.
- Pneumatici da 26x4,8".
- Mondraker Forward Geometry.
- Motore Bosch Performance Cx con batteria PowerPack 500 Wh.
- Display Bosch Purion.
- Battuta mozzo posteriore 12x190 mm.
- Garanzia a vita sul telaio.
- Taglie: S, M, L, XL.
- Colore: Flame Red-Light Blue.



E-PANZER R

Frame	Panzer fatbike 6061 Xtralite Alloy
Shock	-
Fork	RockShox Bluto RL Fat Bike 120mm
Headset	Onoff Saturn Tapered for 1-1/8" -> 1/5"
R. Derailleur	Sram NX Type 3
Chain	Sram PC 1110 11s
Shifters	Sram Nx Trigger
Brakes	Sram Guide RE
Rotors	Sram Centerline 200 mm
Crankset	Miranda Delta crankset 14T
Cassette	Sram PG-1130 11-42T 11s
Handlebar	Onoff Notion 0.2. Aluminium 6061 T6 double-Tapered
Stem	Onoff Stoic FG 30mm. Forged 6061 alloy, 31.8mm bar bore
Grips	Onoff Diamond, 1lock-on, 130mm
Seatpost	Onoff Pija Dropper 31.6mm, internal hose guide
Saddle	Mondraker E-mtb exclusive design
Front Tire	Maxxis Minion FBF 26x4.8, tubeless ready, dual compound, Exo, 120 TPI,
Rear Tire	Maxxis Minion FBF 26x4.8, tubeless ready, dual compound, Exo, 120 TPI
Tubes/Sealant	-
Front Hub	DT Swiss BRM2250
Rear Hub	DT Swiss BRM2250
Rim	DT Swiss BRM2250
Spokes	CN stainless
Weight	21,1 Kg
Prezzo bici	€5.299,00

E-VANTAGE +

La Mondraker e-Vantage va spiegata e per farlo bastano due parole: semplicità e facilità.

Il telaio in lega leggera 6061 e la Forward Geometry permettono a questa hardtail con pedalata assistita di fare grandi cose se chi guida ha una certa “manetta”. Gomme 650b Plus da 2,8” di sezione, motore elettrico Bosch Performance Cx e la nuova batteria integrata Bosch da 500 Wh chiudono un quadro tecnico di primissimo piano.

Se non avere la sospensione posteriore non è una limitazione, allora la e-Vantage fa per voi.

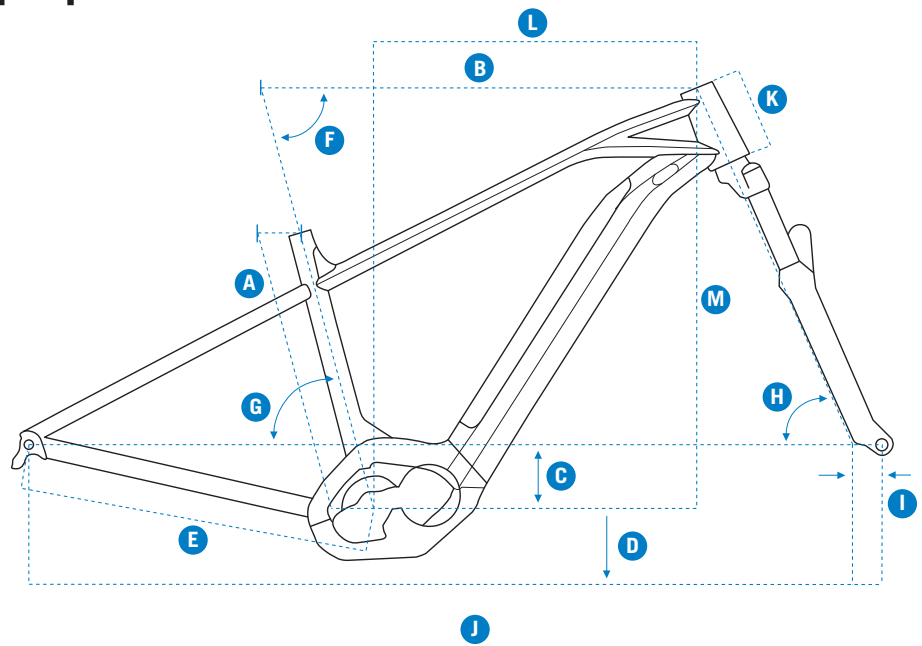

GEOMETRIA

	S	M	L	XL
A Seat Tube Length	380mm	420mm	470mm	510mm
B Top Tube Length	615mm	645mm	670mm	705mm
C Bottom Bracket Drop	-53mm	-53mm	-53mm	-53mm
D Bottom Bracket Height	310mm	310mm	310mm	310mm
E Chainstay Length	475mm	475mm	475mm	475mm
F Seat Tube Angle, Actual	74°	74°	74°	74°
G Seat Tube Angle, Effective	74°	74°	74°	74°
H Head Tube Angle	67°	67°	67°	67°
I Fork Offset	44mm	44mm	44mm	44mm
J Wheelbase	1231mm	1264mm	1292mm	1316mm
K Head Tube Length	100mm	120mm	140mm	150mm
L Reach	454mm	479mm	499mm	519mm
M Stack	595mm	614mm	632mm	641mm

CARATTERISTICHE

- Telaio in lega 6061 Stealth Evo.
- Pneumatici da 27,5x2,8”.
- Mondraker Forward Geometry.
- Motore Bosch Performance Cx con batteria integrata Bosch da 500 Wh.
- Display Bosch Purion.
- Battute mozzi Boost.
- Garanzia a vita sul telaio.
- Taglie: S, M, L, XL.
- Colore: Black-Yellow.



E-VANTAGE R+

Frame	e-Vantage 27,5+ 6061 Alloy Stealth Evo
Shock	-
Fork	Rockshox Revelation 27,5 RC Solo Air 140 mm
Headset	Onoff Saturn Tapered for 1-1/8" -> 1/5"
R. Derailleur	SRAM GX, long cage
Chain	SRAM PC-1031 10s
Shifters	Sram Trigger X5, 10s
Brakes	Sram Level
Rotors	Sram Centerline 200/180 mm
Crankset	Miranda Delta crankset 16T
Cassette	Sunrace CSMCS3 11-42T 10s
Handlebar	Mondraker custom design 1.0 780mm
Stem	Onoff Stoic FG 30mm. Forged 6061 alloy, 31.8mm bar bore
Grips	Onoff Diamond, 1lock-on, 130mm
Seatpost	Onoff Pija Dropper 31.6mm, internal hose guide
Saddle	Mondraker E-mtb exclusive design
Front Tire	Maxxis Rekon 27,5x2.8, tubeless ready, Dual compound, Exo-protection, 60TPI
Rear Tire	Maxxis Rekon 27,5x2.8, tubeless ready, Dual compound, Exo-protection, 60TPI
Tubes/Sealant	-
Front Hub	MDK Pro II 15x110mm
Rear Hub	MDK Pro II 12x148 mm
Rim	NEW MDK-EP1 27,5+ Asy 35 TLR wheelset
Spokes	CN stainless
Weight	ND
Prezzo bici	€4.499,00

E-PRIME +

Se di primo acchito vi piace, quando la userete non vorrete più scendere di sella.

La gamma Mondraker e-Prime Carbon è stata la prima ad adottare un telaio in fibra di carbonio in abbinamento a un motore elettrico. La serie 2018 prevede anche la versione SX+, ossia un allestimento pensato per il commuting e per l'uso urbano.

Le caratteristiche tecniche sono ampiamente riprese dai modelli più votati al divertimento, ma con un'attenzione maggiore allo stile. Le Mondraker e-Prime sono fatte per essere usate e ammirate.

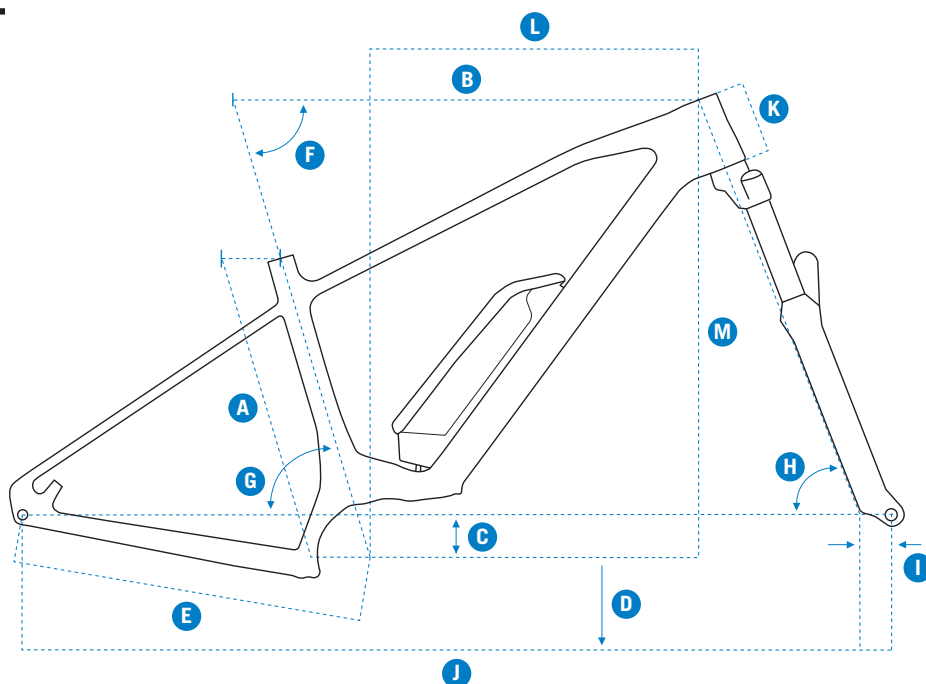

GEOMETRIA

	S	M	L	XL
A Seat Tube Length	390mm	430mm	470mm	510mm
B Top Tube Length	609mm	634mm	657mm	681mm
C Bottom Bracket Drop	-73mm	-73mm	-73mm	-73mm
D Bottom Bracket Height	295mm	295mm	295mm	295mm
E Chainstay Length	480mm	480mm	480mm	480mm
F Seat Tube Angle, Actual	75°	75°	75°	75°
G Seat Tube Angle, Effective	75°	75°	75°	75°
H Head Tube Angle	70°	70°	70°	70°
I Fork Offset	43mm	43mm	43mm	43mm
J Wheelbase	1151mm	1182mm	1213mm	1244mm
K Head Tube Length	90mm	100mm	110mm	120mm
L Reach	440mm	470mm	495mm	525mm
M Stack	605mm	615mm	625mm	635mm

CARATTERISTICHE

- Telaio in fibra di carbonio Stealth.
- Pneumatici da 27,5x2,8".
- Mondraker Forward Geometry.
- Motore Bosch Performance Cx con Bosch PowerPack 500.
- Display Bosch Purion.
- Battute mozzi Boost.
- Garanzia a vita sul telaio.
- Taglie: S, M, L, XL.
- Colore: Carbon-Graphite-Black (e-Prime Carbon SX+)
Carbon-Yellow-Light Blue (E-Prime Carbon R+)
Black-Flame Red-Amber (e-Prime R+)
Black-Light Blue, Flame Red-Black (e-Prime +).





	E-PRIME CARBON SX+	E-PRIME CARBON R+	E-PRIME R+	E-PRIME +
Frame	e-Prime 27,5+ Stealth Full Carbon	e-Prime 27,5+ Stealth Full Carbon	e-Prime 27,5+ 6061 Xtralite Alloy	e-Prime 27,5+ 6061 Xtralite Alloy
Shock	-	-	-	-
Fork	Stealth Full carbon fork 27,5+, 15x110mm	RockShox Judy Gold 27,5+ RL Solo Air 120 mm	Fox 32 27,5 Rhythm Sweep adjust Evol, 120 mm	RockShox Judy Silver TK 27,5+ Solo Air Solo Air 120mm
Headset	Onoff Saturn Tapered for 1-1/8" -> 1/5"	Onoff Saturn Tapered for 1-1/8" -> 1/5"	Onoff Saturn Tapered for 1-1/8" -> 1/5"	Onoff Saturn Tapered for 1-1/8" -> 1/5"
R. Derailleur	Sram GX Type 2.1 11s	Sram GX Type 2.1 10s	Sram NX Type 3	Sram GX, long cage
Chain	Sram PC 1110 11s	Sram PC-1031 10s	Sram PC-1110 11s	Sram PC-1031 10s
Shifters	Sram Trigger GX, 11s	Sram Trigger GX, 10s	Sram Trigger NX1, 11s	Sram Trigger X5, 10s
Brakes	Magura MT5E	Sram Level T	SRAM Level T	Sram Level
Rotors	Magura MT5E 203mm	Sram Centerline 200 mm	Sram Centerline 200/180 mm	Sram Centerline 200/180 mm
Crankset	Sram EX1 crankset 18T	Miranda Delta crankset 16T	Miranda Delta crankset 16T	Miranda Delta crankset 16T
Cassette	Sram PG-1130 11-42T	Sunrace CSMCS3 11-42T 10s	Sram PG-1130 11-42T 11s	Sunrace CSMCS3 11-42T 10s
Handlebar	Mondraker custom design 0.5 760mm	Mondraker custom design 0.5 760 mm	Mondraker custom design 0.5 760 mm	Mondraker custom design 0.5 760 mm
Stem	Onoff Stoic FG 30mm. Forged 6061 alloy, 31.8mm barbore	Onoff Stoic FG 30mm. Forged 6061 alloy, 31.8mm barbore	Onoff Stoic FG 30mm. Forged 6061 alloy, 31.8mm barbore	Onoff Stoic FG 30mm. Forged 6061 alloy, 31.8mm barbore
Grips	Onoff Diamond, 1lock-on, 130mm	Onoff Diamond, 1lock-on, 130mm	Onoff Diamond, 1lock-on, 130mm	Onoff Diamond, 1lock-on, 130mm
Seatpost	Onoff Notion O-R. aluminium 2014 T6 2D-molded head, 31.6mm-400mm.	Onoff Pija Dropper 31.6mm, internal hose guide	Onoff Pija Dropper 31.6mm, internal hose guide	Onoff Pija Dropper 31.6mm, internal hose guide
Saddle	Mondraker e-Prime Carbon SX + exclusive design	Exclusive Mondraker e-Prime Carbon R+ design	Exclusive Mondraker e-Prime R+ design	Exclusive Mondraker e-Prime R+ design
Front Tire	Schwalbe Super Moto X 27.5x2.8, Race-Guard, SnakeSkin, ECE-R75	Kenda Havok 27.5x2.8, TLR, DTC, EMC, 120TPI, folding	Kenda Havok 27.5x2.8, TLR, DTC, EMC, 120TPI, folding	Kenda Havok 27.5x2.8, TLR, DTC, EMC, 120TPI, folding
Rear Tire	Schwalbe Super Moto X 27.5x2.8, Race-Guard, SnakeSkin, ECE-R75	Kenda Havok 27.5x2.8, TLR, DTC, EMC, 120TPI, folding	Kenda Havok 27.5x2.8, TLR, DTC, EMC, 120TPI, folding	Kenda Havok 27.5x2.8, TLR, DTC, EMC, 120TPI, folding
Tubes/Sealant	-	-	-	-
Front Hub	DT Swiss 370, Boost 15x110mm axle, IS 6 bolts mount	MDK Pro II 15x110mm	MDK Pro II 15x110mm	MDK Pro II 15x110mm
Rear Hub	DT Swiss 370, Boost 12x148 mm axle, IS 6 bolts mount	MDK Pro II 12x148mm	MDK Pro II 12x148mm	MDK Pro II 12x148mm
Rim	DT Swiss H1900 Spline 27,5, internal width 35mm, e-bike specific, tubeless	NEW MDK-EP1 27,5+ Asy 35 TLR wheelsset	NEW MDK-EP1 27,5+ Asy 35 TLR	NEW MDK-EP1 27,5+ Asy 35 TLR
Spokes	Hybrid sytem, stainless steel	CN stainless	CN stainless	CN stainless
Weight	18,2 Kg	20,1 Kg	20,6 Kg	20,8 Kg
Prezzo bici	€5.299,00	€4.599,00	€4.199,00	€2.999,00

SUMMUM

È una bici che cambia le regole di guida.

La Mondraker Summum (disponibile sia con telaio in fibra di carbonio che in lega d'alluminio) è la bici che premia il talento di guida e allo stesso tempo è in grado di mettere a proprio agio qualunque biker.

La sospensione Zero con travel di 205 mm e i cuscinetti sigillati è capace di un livello di rigidità torsionale da riferimento.

L'arrivo della versione in carbonio ha spalancato orizzonti gloriosi alla Mondraker Summum e la conquista del podio del Mondiale Dh 2016 in Val di Sole ne è la testimonianza.

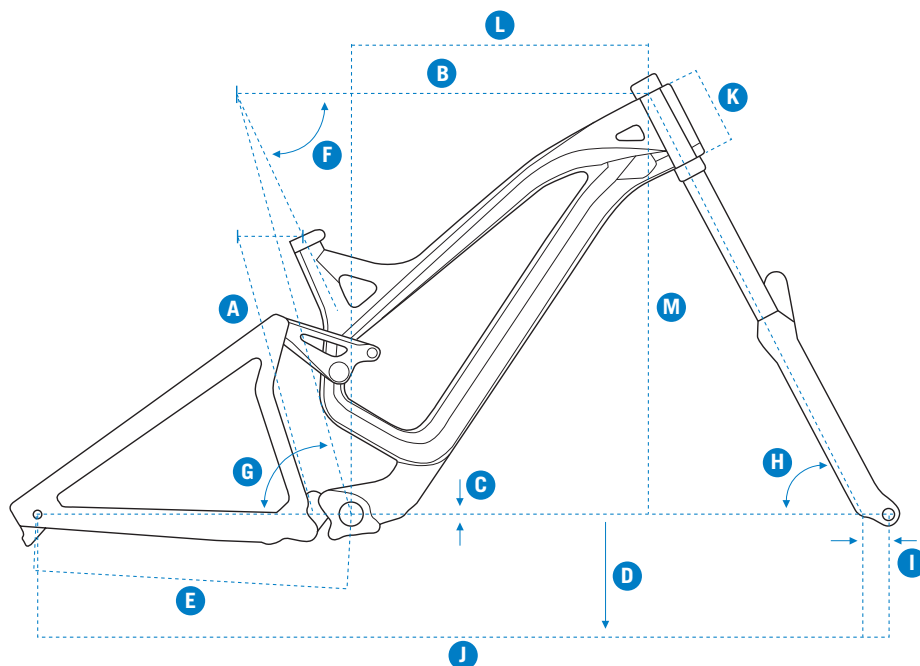

GEOMETRIA

	S	M	L	XL
A Seat Tube Length	400mm	400mm	400mm	400mm
B Top Tube Length	575mm	600mm	622mm	647mm
C Bottom Bracket Drop	0mm	0mm	0mm	0mm
D Bottom Bracket Height	350mm	350mm	350mm	350mm
E Chainstay Length	445 - 460mm	445 - 460mm	445 - 460mm	445 - 460mm
F Seat Tube Angle, Actual	65°	65°	65°	65°
G Seat Tube Angle, Effective	73.5°	73.5°	73.5°	73.5°
H Head Tube Angle	63° (+/-2°)	63° (+/-2°)	63° (+/-2°)	63° (+/-2°)
I Fork Offset	52mm	52mm	52mm	52mm
J Wheelbase	1200mm	1225mm	1250mm	1280mm
K Head Tube Length	112mm	112mm	122mm	122mm
L Reach	397mm	422mm	442mm	468mm
M Stack	597mm	597mm	606mm	606mm

CARATTERISTICHE

- 205 mm di escursione.
- Compatibile con ruote da 27,5".
- Telaio in fibra di carbonio Stealth o in lega leggera 6061 Alloy Stealth Evo.
- Mondraker Forward Geometry.
- Geometria regolabile tramite accessori opzionali (di serie sulla Carbon Pro Team).
- Battuta mozzo posteriore 12x150 mm.
- Cuscinetti sospensione sigillati MAX.
- Garanzia a vita sul telaio.
- Taglie: S, M, L, XL.
- Colore: Carbon-Light Blue-Flame Red (Summum Carbon Pro Team)
Carbon-Flame Red-Amber (Summum Carbon Pro)
Flame Red-Light Blue-White (Summum Pro), Vibrant Blue-Black-Orange (Summum).





	SUMMUM CARBON PRO TEAM	SUMMUM CARBON PRO	SUMMUM PRO	SUMMUM
Frame	Summum 27,5 Stealth Full Carbon	Summum 27,5 Stealth Full Carbon	Summum 6061 Alloy Stealth Evo, hydroformed tubing	Summum 6061 Alloy Stealth Evo, hydroformed tubing
Shock	Fox DHX2 Factory Kashima 222x70mm	Fox DHX2 Performance Elite 222x70mm	Fox DHX2 Performance Elite 222x70mm	Fox Van RC Performance 222x70mm
Fork	Fox 40 27,5 Float FIT HSC LSC EVOL Factory Kashima 203mm	Fox 40 27,5 Float FIT4 LSC EVOL Performance Elite 203 mm	Fox 40 27,5 Float FIT4 LSC EVOL Performance Elite 203 mm	Marzocchi 380 27,5' CR 200mm, Coil Spring
Headset	Internal Onoff Mercurium 1.5 ZS for 1-1/8" head tube	Internal Onoff Mercurium 1.5 ZS for 1-1/8" head tube	Internal Onoff Mercurium 1.5 ZS for 1-1/8" head tube	Internal Onoff Mercurium 1.5 ZS for 1-1/8" head tube
R. Derailleur	Shimano Saint RD-M820-SS 10s. Shadow Plus technology. Short cage	Shimano Zee RD-M640-SS 10s. Shadow Plus technology. Short cage	Shimano Zee RD-M640-SS 10s. Shadow Plus technology. Short cage	Sram X7 9s short cage
Chain	Shimano HG95 10s	Shimano HG95 10s	Shimano HG95 10s	SRAM PC-951 9s
Shifters	Shimano Saint SL-M820 10s	Shimano Zee SL-M640 10s	Shimano Zee SL-M640 10s	Sram Trigger X5
Brakes	Shimano Saint M820	Sram Guide R	Sram Guide R	Sram Guide R
Rotors	Shimano RT86 2-piece 6 bolts 203 rotor ICE tech, resin pads with cooler	Sram Centerline 203 mm	Sram Centerline 203 mm	Sram G2 203 mm
Crankset	Shimano Saint M825. HOLLOWTECH II technology, 165mm, 36 T	Shimano Zee M645, alloy, reinforced steel axle. 165mm, 36 T	Shimano Zee M645, alloy, reinforced steel axle. 165mm, 36 T	Truvativ Ruktion 1.0, Alloy HP cast arm, 165mm, 36 T
Cassette	Shimano Ultegra CS-HG6700, 11-25T, 10s	Shimano CS-HG500-10 11-25T, 10s	Shimano CS-HG500-10 11-25T, 10s	Sram PG-950 11-26T 9s
Handlebar	Renthal Fatbar series 7 alloy, rise: 30mm, width: 780mm	Mondraker double butted 6061 aluminium, design for Summum Pro	Mondraker double butted 6061 aluminium, design for Summum Pro	Mondraker double butted 6061 aluminium, design for Summum Pro
Stem	Onoff Stoic DH Integrated FG, 20-30mm adjustable length	Onoff Stoic DH Integrated FG, 20-30mm adjustable length	Onoff Stoic DH Integrated FG, 20-30mm adjustable length	Onoff Stoic DH Integrated FG, 20-30mm adjustable length
Grips	Renthal, double lock-on. Made with kevlar, 130mm	Onoff Diamond, 1lock-on, 130mm	Onoff Diamond, 1lock-on, 130mm	Onoff Diamond, 1lock-on, 130mm
Seatpost	SDG I-Beam SP-951 Carbon 31.6 300mm	SDG I-Beam SP-751 Alloy 31.6, 300mm length and micro-adjustment	SDG I-Beam SP-751 Alloy 31.6, 300mm length and micro-adjustment	SDG I-Beam SP-751 Alloy 31.6, 300mm length and micro-adjustment
Saddle	SDG I-beam I - Fly 2.0 Eva	SDG I-Beam I-Fly 2.0. High-density PU, lateral protection in cordura	SDG I-Beam I-Fly 2.0. High-density PU, lateral protection in cordura	SDG I-Beam I-Fly 2.0. High-density PU, lateral protection in cordura
Front Tire	Maxxis Minion DHR II 27,5 x 2.4 Super Tacky Compound, Wire	Maxxis Minion DHR II 27,5 x 2.4 Super Tacky Compound, Wire	Maxxis Minion DHR II 27,5 x 2.4 Super Tacky Compound, Wire	Maxxis Minion DHR II 27,5 x 2.4 Super Tacky Compound, Wire
Rear Tire	Maxxis Minion DHR II 27,5 x 2.4 Super Tacky Compound, Wire	Maxxis Minion DHR II 27,5 x 2.4 Super Tacky Compound, Wire	Maxxis Minion DHR II 27,5 x 2.4 Super Tacky Compound, Wire	Maxxis Minion DHR II 27,5 x 2.4 Super Tacky Compound, Wire
Tubes/Sealant	-	-	-	-
Front Hub	DT Classic 240 20x110mm, IS 6 bolts	MDK Disc Pro DH 20x110mm, IS 6 bolts	MDK Disc Pro DH 20x110mm, IS 6 bolts	MDK Disc Pro DH 20x110mm, IS 6 bolts
Rear Hub	DT Classic 240 Ratchet system 12x150mm, IS 6 bolts	MDK Disc Pro DH 12x150mm, sealed bearings, IS 6 bolts	MDK Disc Pro DH 12x150mm, sealed bearings, IS 6 bolts	MDK Disc Pro DH 12x150mm, sealed bearings, IS 6 bolts
Rim	Dt Swiss FR1950 27,5, 33mm external width, tubeless ready	Dt Swiss FR570 27,5, 33mm external width, tubeless ready. 32 holes	Dt Swiss FR570 27,5, 33mm external width, tubeless ready. 32 holes	MDK-DP1 27,5 32mm external width. 32 holes
Spokes	DT competition, black	CN stainless steel butted 2.0-1.8-2.0	CN stainless steel butted 2.0-1.8-2.0	CN stainless steel
Weight	16,6 Kg	16,5 Kg	17 Kg	17 Kg
Prezzo telaio	€4.199,00	-	€2.499,00	-
Prezzo bici	€8.999,00	€6.499,00	€4.999,00	€3.599,00

DUNE

Insieme alla Summum, la Dune è stata una delle prime Mondraker a portare al debutto la Forward Geometry.

Non è stata accolta con entusiasmo unanime, ha destato perplessità, ha richiesto cambiamenti importanti nello stile di guida, ma ora è diventata un riferimento per molti altri marchi.

La Mondraker Dune è la macchina da gara che si trova a suo agio nelle Speciali.

160 mm di escursione e telaio sia in fibra di carbonio che in lega d'alluminio.

Preparati ad andare davvero forte e a scegliere bene la traiettoria...

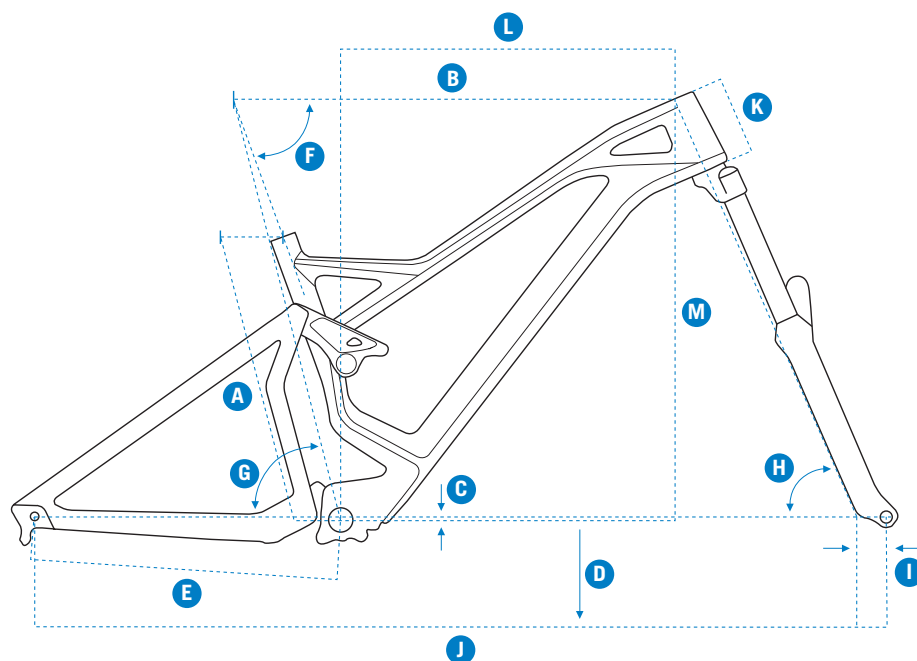

GEOMETRIA

	S	M	L	XL
A Seat Tube Length	380mm	420mm	470mm	510mm
B Top Tube Length	610mm	630mm	655mm	673mm
C Bottom Bracket Drop	-5mm	-5mm	-5mm	-5mm
D Bottom Bracket Height	350mm	350mm	350mm	350mm
E Chainstay Length	430 - 440mm	430 - 440mm	430 - 440mm	430 - 440mm
F Seat Tube Angle, Actual	69.9°	69.9°	69.9°	69.9°
G Seat Tube Angle, Effective	74.7°	74.7°	74.7°	74.7°
H Head Tube Angle	66° (+/-1°)	66° (+/-1°)	66° (+/-1°)	66° (+/-1°)
I Fork Offset	44mm	44mm	44mm	44mm
J Wheelbase	1198mm	1218mm	1243mm	1265mm
K Head Tube Length	110mm	110mm	120mm	130mm
L Reach	452mm	472mm	493mm	508mm
M Stack	596mm	596mm	606mm	613mm

CARATTERISTICHE

- 160 mm di escursione.
- Compatibile con ruote da 27,5".
- Telaio in fibra di carbonio Stealth o in lega leggera 6061 Alloy Stealth Evo.
- Mondraker Forward Geometry.
- Geometria regolabile tramite accessori opzionali (di serie sulla Dune Xr Carbon).
- Battuta mozzo posteriore 12x142 mm Carbon e 12x148 mm Alloy.
- Cuscinetti sospensione sigillati MAX.
- Garanzia a vita sul telaio.
- Taglie: S, M, L, XL.
- Colore: Carbon-Light Blue-Flame Red (Dune Carbon XR)
Carbon-Fuchsia-Yellow (Dune Carbon RR), Carbon-Amber-White (Dune Carbon R)
Light Blue-Black-Flame Red (Dune R), Black-Light Blue-Yellow (Dune).





	DUNE CARBON XR	DUNE CARBON RR	DUNE CARBON R
Frame	Dune 27,5' Stealth full Carbon	Dune 27,5' Stealth full Carbon	Dune 27,5' Stealth full Carbon
Shock	Fox DHX2 2Pos Lever Factory Kashima 215x63.5mm	Fox Float X2 Factory Kashima	Fox Float X2 Performance
Fork	Fox 36 27,5 Float FIT4 EVOL Factory Kashima 170mm	Fox 36 27,5 Float FIT4 EVOL Factory Kashima 170mm	Fox 36 27,5 Float Grip EVOL Performance 170mm
Headset	Onoff Titan internally Tapered for 1-1/8" -> 1/5" head tube	Onoff Titan internally Tapered for 1-1/8" -> 1/5" head tube	Onoff Titan internally Tapered for 1-1/8" -> 1/5" head tube
R. Derailleur	SRAM X01 Eagle Type 3	SRAM X01 Eagle Type 3	Sram GX1 Type 2.1
Chain	SRAM GX Eagle 12s	SRAM GX Eagle 12s	SRAM PC-1110 11s
Shifters	Sram Trigger X01 Eagle	Sram Trigger GX Eagle	Sram Trigger NX1, 11s
Brakes	Sram Guide RS	Sram Guide R	Sram Guide R
Rotors	Sram Centerline 200 mm	Sram Centerline 200 mm	Sram Centerline 200/180 mm
Crankset	SRAM X1 Eagle 12s carbon crank arms	Truativ Descendant 7K Eagle	SRAM NX16000 series aluminium, 24mm axle
Cassette	SRAM XG-1275 10-50T	SRAM XG-1275 10-50T	Sunrace CSMS8, 11-46T, 11s
Handlebar	Onoff Stoic Carbon. Exclusive Dune Carbon XR design	Onoff Stoic Carbon. Exclusive Dune Carbon RR design	Mondraker double butted 6061 aluminium, Exclusive Dune R design
Stem	Onoff Stoic FG 30mm. 6061 forged aluminium. 35mm barbore	Onoff Stoic FG 30mm. 6061 forged aluminium. 35mm barbore	Onoff Stoic FG 30mm. 6061 forged aluminium. 31.8mm barbore
Grips	Onoff Diamond, 1lock-on, 130mm	Onoff Diamond, 1lock-on, 130mm	Onoff Diamond, 1lock-on, 130mm
Seatpost	Fox Transfer Performance Elite internal 31.6mm, internal hose guide	Fox Transfer Performance Elite internal 31.6mm, internal hose guide	Onoff Pija Dropper 31.6mm, internal hose guide
Saddle	SDG Circuit MTN T1, High-density PU, titanium rail, black Cordura sides	SDG Fly MTN T1, High-density PU, chromium rail, cordura sides protection	SDG Fly MTN T1, High-density PU, chromium rail, cordura sides protection
Front Tire	Maxxis High Roller II 27,5'x2.3 Tubeless ready, dual compound, Exo, 60 TPI	Maxxis High Roller II 27,5'x2.3 Tubeless ready, dual compound, Exo, 60 TPI	Maxxis High Roller II 27,5'x2.3 Tubeless ready, dual compound, Exo, 60 TPI
Rear Tire	Maxxis High Roller II 27,5'x2.3 Tubeless ready, dual compound, Exo, 60 TPI	Maxxis High Roller II 27,5'x2.3 Tubeless ready, dual compound, Exo, 60 TPI	Maxxis High Roller II 27,5'x2.3 Tubeless ready, dual compound, Exo, 60 TPI
Tubes/Sealant	-	-	-
Front Hub	Spline One 240s, 15mm axel, 6 bolts rotor	Mavic XA Elite 15x110mm, IS 6 bolts mount	MDK DC511 15x110mm, sealed bearings, IS 6 bolts mount
Rear Hub	Spline One 240s 36T Ratchet System, 12x142mm, 6 bolts rotor and Sram XD	Mavic XA Elite 12x142mm, ITS4 with 4 ratchets, 6 bolts rotor and XD 1x11	MDK GW 12x142mm, sealed bearings, IS 6 bolts mount
Rim	Dt Swiss EX1501 Spline One 27,5' 30mm internal width, tubeless	Mavic XA Elite. 25mm internal width, hookless, tubeless ready, 24 spokes	MDK-EP1 27,5 TLR ASY, internal width 27mm, tubeless ready, 32 spokes
Spokes	DT Competition, straight pull	Mavic steal straight pull	CN round stainless steel
Weight	13,3 Kg	13,1 Kg	13,7 Kg
Prezzo telaio	€3.999,00	-	-
Prezzo bici	€8.699,00	€6.999,00	€5.799,00

DUNE
R

DUNE

Frame	Dune 6061 Alloy Stealth Evo, hydroformed tubing	Dune 6061 Alloy Stealth Evo, hydroformed tubing
Shock	Fox Float DPX2 LV EVOL Performance	RockShox Monarch Plus R
Fork	Fox 36 27,5 Float Grip EVOL Performance 170 mm	RockShox Yari 27.5" RC 170mm
Headset	Onoff Saturn Tapered for 1-1/8" -> 1/5" head tube.	Onoff Saturn Tapered for 1-1/8" -> 1/5" head tube
R. Derailleur	Sram GX Eagle Type 3	Sram NX Type 3
Chain	SRAM GX Eagle 12s	SRAM PC-1110 11s
Shifters	Sram Trigger GX Eagle 12s	Sram Trigger NX1
Brakes	Sram Guide R	Sram Level T
Rotors	Sram Centerline 200/180 mm	Sram Centerline 200/180 mm
Crankset	Truvativ Descendant 7K Eagle, aluminium crank arms, 24 mm axle	FSA Gamma 2x10, aluminium cranks
Cassette	SRAM XG-1275 10-50T	Sunrace CSMS7, 11-42T, 11s
Handlebar	Mondraker aluminium 6061 double butted. Exclusive Dune R design	Mondraker aluminium 6061 double butted. Exclusive Dune design
Stem	Onoff Stoic FG 30mm. 6061 forged aluminium. 31.8mm barbore	Onoff Stoic FG 30mm. 6061 forged aluminium. 31.8mm barbore
Grips	Onoff Diamond, 1lock-on, 130mm	Onoff Diamond, 1lock-on, 130mm
Seatpost	Onoff Pija Dropper 31.6mm, internal hose guide	Onoff Pija Dropper 31.6mm, internal hose guide
Saddle	SDG Circuit MTN, High-density PU, black steel rail, Cordura sides	SDG Fly MTN, High-density PU, steel rail, black Cordura sides
Front Tire	Maxxis High Roller II 27,5 x 2.3 Tubeless Ready, Dual compound, Exo, 60TPI	Maxxis High Roller II 27,5 x 2.3 Tubeless Ready, Dual compound, Exo, 60TPI
Rear Tire	Maxxis High Roller II 27,5 x 2.3 Tubeless Ready, Dual compound, Exo, 60TPI	Maxxis High Roller II 27,5 x 2.3 Tubeless Ready, Dual compound, Exo, 60TPI
Tubes/Sealant	-	-
Front Hub	Mavic 15x110mm, sealed bearings, IS 6 bolts mount	MDK DC511 15x110mm, sealed bearings, IS 6 bolts mount
Rear Hub	Mavic 12x148mm, sealed bearings, TS-2 freehub for XD, IS 6 bolts	MDK GW 12x148mm, sealed bearings, IS 6 bolts mount
Rim	Mavic XA 27,5, Tubeless Ready, internal width 25mm	MDK-EP1 27,5 TLR ASY, asymmetrical rim, internal width 27mm, tubeless
Spokes	Mavic Steel, straight-pull	CN round stainless steel
Weight	13,8 Kg	14,4 Kg
Prezzo telaio	€1.999,00	-
Prezzo bici	€4.499,00	€3.199,00





FOXY

La Mondraker Foxy fa di tutto per sfuggire alla definizione di trail bike. È qualcosa di più e allo stesso tempo è perfettamente una trail bike, cioè una bici per essere guidata con spavalderia. E grande soddisfazione. Nel catalogo Mondraker è una delle bici più raffinate perchè eredita tutte le caratteristiche di spicco di Summum e Dune, vale a dire il telaio in carbonio (disponibile anche in lega), la sospensione Zero, la Forward Geometry e pur avendo solo 150 mm di corsa è una bici capace di numeri pazzeschi. C'è in opzione il kit per regolare la geometria del telaio.

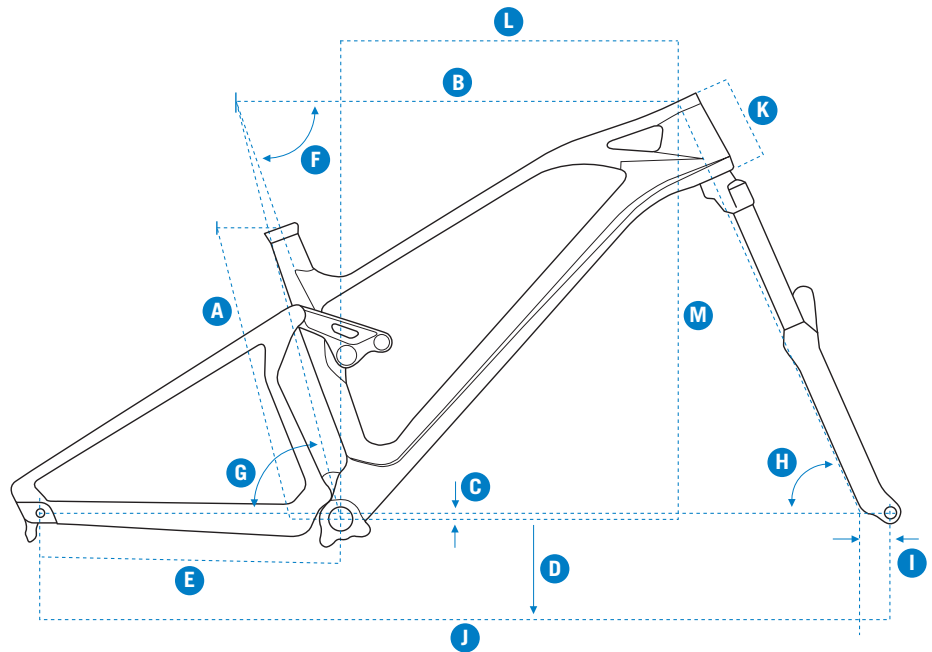

GEOMETRIA

	S	M	L	XL
A Seat Tube Length	380mm	420mm	470mm	510mm
B Top Tube Length	616mm	638mm	663mm	686mm
C Bottom Bracket Drop	-9mm	-9mm	-9mm	-9mm
D Bottom Bracket Height	345mm	345mm	345mm	345mm
E Chainstay Length	425-435mm	425-435mm	425-435mm	425-435mm
F Seat Tube Angle, Actual	70.5°	70.5°	70.5°	70.5°
G Seat Tube Angle, Effective	75°	75°	75°	75°
H Head Tube Angle	66°	66°	66°	66°
I Fork Offset	44mm	44mm	44mm	44mm
J Wheelbase	1189mm	1213mm	1241mm	1265mm
K Head Tube Length	110mm	120mm	140mm	150mm
L Reach	460mm	480mm	500mm	520mm
M Stack	584mm	593mm	611mm	620mm

CARATTERISTICHE

- 150 mm di escursione.
- Compatibile con ruote da 27,5".
- Telaio in fibra di carbonio Stealth o in lega leggera 6061 Alloy Stealth Evo.
- Mondraker Forward Geometry.
- Geometria regolabile tramite accessori opzionali (di serie sulla Foxy Carbon RR SL).
- Battuta mozzo posteriore 12x148 mm.
- Cuscinetti sospensione sigillati Enduro MAX.
- Garanzia a vita sul telaio.
- Taglie: S, M, L, XL.
- Colore: Carbon-Light Blue-Flame Red (Foxy Carbon RR SL)
Yellow-Black-Orange (Foxy Carbon XR), Flame Red-Black-Light Blue (Foxy Carbon RR)
Vibrant Blue-Black-Yellow (Foxy Carbon R), Black-Amber-Light Blue (Foxy).





	FOXY CARBON RR SL	FOXY CARBON XR	FOXY CARBON RR	FOXY CARBON R
Frame	Foxy 27,5 Stealth Air full Carbon Structure	Foxy 27,5 Stealth Air full Carbon Structure	Foxy 27,5 Stealth Air full Carbon Structure	Foxy 27,5 Stealth Air full Carbon Structure
Shock	Fox Float DPX2 LV EVOL Factory Kashima	RockShox Superdeluxe Coil RCT	Fox Float DPX2 LV EVOL Performance	RockShox Deluxe RL Debonair
Fork	Fox 34 27,5 Float FIT4 EVOL Factory Kashima 150mm	RockShox Pike 27,5 RCT3, Charger 2, Debon Air, 160mm	Fox 34 Float 27,5 Grip Performance EVOL, 150mm	Rockshox Revelation RC Solo Air, 150mm
Headset	Onoff Saturn Tapered for 1-1/8" -> 1/5" head tube	Onoff Saturn Tapered for 1-1/8" -> 1/5" head tube	Onoff Saturn Tapered for 1-1/8" -> 1/5" head tube	Onoff Saturn Tapered for 1-1/8" -> 1/5" head tube
R. Derailleur	SRAM X01 Eagle Type 3	Sram GX Eagle Type 3	Sram GX Eagle Type 3	Sram NX Type 3
Chain	SRAM X01 Eagle 12s	Sram GX Eagle 12s	Sram GX Eagle 12s	SRAM PC-1110 11s
Shifters	Sram Trigger X01 Eagle	Sram Trigger GX Eagle 12s	Sram Trigger GX Eagle 12s	Sram Trigger NX1
Brakes	Shimano XTR M9020	Shimano XT M8000	Shimano XT M8000	Shimano MT-500
Rotors	Shimano RT99 Ice-Tech CL 200/180 mm	Shimano RT76 203/180 mm	Shimano RT76 203/180 mm	Shimano 203/180 mm
Crankset	Sram X01 Eagle, carbon crank arms	Truativ Descendant Eagle Carbon	RaceFace Aeffect 12s, Molded aluminium 6066	SRAM NX16000 series aluminium
Cassette	SRAM XG-1295 10-50T	SRAM XG-1275 10-50T	SRAM XG-1275 10-50T	Sunrace CSMS8, 11-46T, 11s
Handlebar	Onoff Stoic Carbon. Exclusive design for Foxy Carbon RR SL	Onoff Stoic Carbon. Exclusive design for Foxy Carbon XR	Mondraker 6061 Aluminium 6061 double-Tapered for Foxy Carbon RR	Mondraker 6061 Aluminium 6061 double-Tapered for Foxy Carbon R
Stem	Onoff Stoic FG 30mm. Molded aluminium 6061, handlebar diameter 35mm	Onoff Stoic FG 30mm. Molded aluminium 6061, handlebar diameter 35mm	Onoff Stoic FG 30mm. Molded aluminium 6061, handlebar diameter 35mm	Onoff Stoic FG 30mm. Molded aluminium 6061, handlebar diameter 35mm
Grips	Onoff Diamond, 1lock-on, 130mm	Onoff Diamond, 1lock-on, 130mm	Onoff Diamond, 1lock-on, 130mm	Onoff Diamond, 1lock-on, 130mm
Seatpost	Fox Transfer Performance Elite internal 31.6mm, internal hose guide	Onoff Pija Dropper 31.6mm, internal hose guide.	Onoff Pija Dropper 31.6mm, internal hose guide.	Onoff Pija Dropper 31.6mm, internal hose guide.
Saddle	SDG Fly MTN TI, High-density PU, titanium rails, cordura sides	SDG Fly MTN, High-density PU, steel rails, cordura sides	SDG Fly MTN, High-density PU, steel rails, cordura sides	Mondraker Foxy Carbon R exclusive design
Front Tire	Maxxis High Roller II 27,5x2.3 Tubeless Ready, Dual compound, Exo, 60TPI	Maxxis High Roller II 27,5x2.3 Tubeless Ready, Dual compound, Exo, 60TPI	Maxxis High Roller II 27,5x2.3 Tubeless Ready, Dual compound, Exo, 60TPI	Maxxis Ardent 27,5x2.40. Single compound, 60 TPI, wire
Rear Tire	Maxxis High Roller II 27,5x2.3 Tubeless Ready, Dual compound, Exo, 60TPI	Maxxis High Roller II 27,5x2.3 Tubeless Ready, Dual compound, Exo, 60TPI	Maxxis High Roller II 27,5x2.3 Tubeless Ready, Dual compound, Exo, 60TPI	Maxxis Ardent 27,5x2.40. Single compound, 60 TPI, wire.
Tubes/Sealant	-	-	-	-
Front Hub	DT Spline One 240s, 15x110mm	DT Spline 15x110mm, IS 6 bolts mount.	Mavic Boost axle 15x110mm, sealed bearings, IS 6 bolts mount.	MDK DC511 15x110mm, sealed bearings, IS 6 bolts mount
Rear Hub	DT Spline One 240s, 12x148mm, XD freehub	DT Spline 12x148mm, XD freehub, IS 6 bolts mount	Mavic, Boost axle 12x148mm, sealed bearings, TS-2 freehub for XD	MDK GW 12x148mm, sealed bearings, IS 6 bolts mount
Rim	DT Swiss XM1501 Spline One 27,5 internal width 30mm	DT Swiss M1700 Spline 27,5	Mavic XA 27,5, Tubeless Ready, internal width 25mm, asymmetrical rim	MDK-EP1 27,5 TLR ASY, internal width 27mm, tubeless
Spokes	Dt Competition, straight	Dt Competition, straight	Mavic Steel, straight-pull	CN round stainless steel
Weight	12,1 Kg	13,6 Kg	13,1 Kg	13,6 Kg
Prezzo telaio	€3.499,00	-	-	-
Prezzo bici	€8.499,00	€6.199,00	€4.999,00	€4.199,00



FOXY

Frame	Foxy 27,5 6061 Alloy Stealth Evo
Shock	RockShox Monarch RT Solo Air HV tube
Fork	Rockshox Reba 27,5 RL Solo Air, 150mm
Headset	Onoff Saturn Tapered for 1-1/8" -> 1/5" head tube
R. Derailleur	Sram NX Type 3
Chain	SRAM PC-1110 11s
Shifters	Sram Trigger NX1, 11s
Brakes	SRAM Level T
Rotors	Sram Centerline 180 mm
Crankset	SRAM NX16000 series aluminium
Cassette	Sunrace CSMS8, 11-46T, 11s
Handlebar	Mondraker 6061 Aluminium 6061 double-Tapered. Ddesign for Foxy
Stem	Onoff Stoic FG 30mm. 6061 forged aluminium. 31.8mm barbore
Grips	Onoff Diamond, 1lock-on, 130mm
Seatpost	Onoff Pija Dropper 31.6mm, internal hose guide
Saddle	Exclusive Mondraker Foxy R design
Front Tire	Maxxis Ardent 27,5x2.40. Single compound, 60 TPI, wire
Rear Tire	Maxxis Ardent 27,5x2.40. Single compound, 60 TPI, wire
Tubes/Sealant	-
Front Hub	MDK DC511 15x110mm, sealed bearings, IS 6 bolts mount
Rear Hub	MDK GW 12x148mm, sealed bearings, IS 6 bolts mount
Rim	MDK-EP1 27,5 TLR ASY, internal width 27mm, tubeless ready
Spokes	CN round stainless steel
Weight	13,8 Kg
Prezzo telaio	€1.849,00
Prezzo bici	€2.999,00





VANTAGE

La Mondraker Vantage rappresenta qualcosa di veramente unico e allo stesso tempo estremo: una hardtail con telaio in lega leggera 6061 con geometria pensata per guidare forte. La forcella da 140 mm di escursione, l'angolo di sterzo da 66° e la Forward Geometry rendono questa bici un piacere unico in discesa.

La Vantage ha una sola regola: più semplice uguale più veloce.

La battuta Boost, infine, aiuta a migliorare la precisione di guida. Se non vi piacciono le sospensioni posteriori, questa bici ha ciò che occorre per mandarvi fuori di testa.

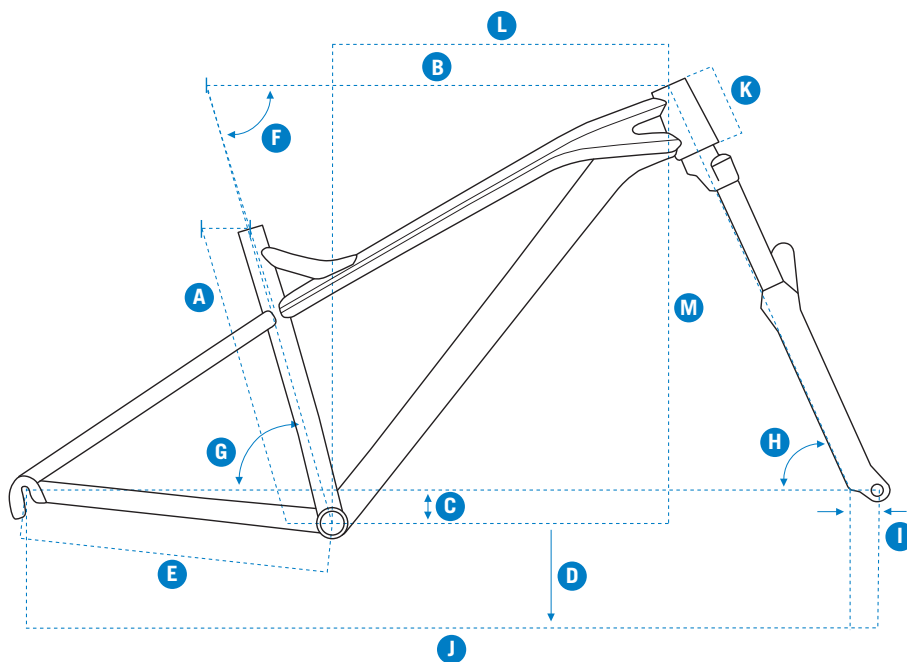

GEOMETRIA

	S	M	L	XL
A Seat Tube Length	380mm	420mm	470mm	510mm
B Top Tube Length	615mm	635mm	660mm	680mm
C Bottom Bracket Drop	-50mm	-50mm	-50mm	-50mm
D Bottom Bracket Height	300mm	300mm	300mm	300mm
E Chainstay Length	425mm	425mm	425mm	425mm
F Seat Tube Angle, Actual	74°	74°	74°	74°
G Seat Tube Angle, Effective	74°	74°	74°	74°
H Head Tube Angle	66°	66°	66°	66°
I Fork Offset	44mm	44mm	44mm	44mm
J Wheelbase	1161mm	1181mm	1207mm	1229mm
K Head Tube Length	100mm	100mm	110mm	120mm
L Reach	442mm	462mm	484mm	502mm
M Stack	601mm	601mm	610mm	620mm

CARATTERISTICHE

- Forcella da 140 mm di escursione.
- Angolo di sterzo da 66°.
- Compatibile con ruote da 27,5".
- Telaio in lega leggera 6061 Alloy Stealth Evo.
- Mondraker Forward Geometry.
- Battuta mozzo posteriore 12x148 mm.
- Garanzia a vita sul telaio.
- Taglie: S, M, L, XL.
- Colore: Light Blue-Flame Red (Vantage RR)
Yellow-Orange (Vantage R)
Flame Red-Navy (Vantage).





VANTAGE RR

VANTAGE R

VANTAGE

	VANTAGE RR	VANTAGE R	VANTAGE
Frame	Vantage 27,5 6061 Alloy Stealth Evo	Vantage 27,5 6061 Alloy Stealth Evo	Vantage 27,5 6061 Alloy Stealth Evo
Shock	-	-	-
Fork	Fox 34 27,5 Rhythm Sweep adjust EVOL, 140mm	RockShox Recon RL 27,5 Solo Air, 140mm	RST Blaze 27,5 TNL 130mm, 1-1/8" steering tube, 9mm QR axle
Headset	Onoff Saturn Tapered for 1-1/8" -> 1/5" head tube	Onoff Saturn Tapered for 1-1/8" -> 1/5" head tube	Onoff Saturn Tapered for 1-1/8" -> 1/5" head tube
R. Derailleur	Sram NX Type 3	SRAM GX, long cage	Shimano Alivio RD-M4000 SGS
Chain	Sram PC-1110 11s	SRAM PC1031 10s	KMC Z99
Shifters	Sram Trigger NX1, 11s	Sram Trigger X5, 10s	Shimano Acera SL-M300, rapidfire plus, 2x9s
Brakes	Sram Guide R	SRAM Level T	Tektro hydraulic brake
Rotors	Sram Centerline 180 mm	Sram Centerline 180 mm	Tektro 180 mm
Crankset	Sram NX1, forged 6066 aluminium	SRAM NX16000 series aluminium, 24mm axle	Suntour XCM 2x9s
Cassette	Sunrace CSMS8, 11-46T, 11s	Sunrace CSMCS3, 11-42T, 10s	Sunrace CS-M909 11-34t 9s
Handlebar	Mondraker aluminium 6061 double butted	Mondraker aluminium 6061 double butted	Mondraker aluminium 6061 double butted
Stem	Onoff Stoic FG 30mm. 6061 forged aluminium. 31.8mm barbore	Onoff Stoic FG 30mm. 6061 forged aluminium. 31.8mm barbore	Onoff Stoic FG 30mm. 6061 forged aluminium. 31.8mm barbore
Grips	Onoff Diamond, 1lock-on, 130mm	Onoff Diamond, 1lock-on, 130mm	Onoff Wave, Kraton/gel, 130mm
Seatpost	Onoff Pija Dropper 31.6mm, internal hose guide	Onoff Pija Dropper 31.6mm, internal hose guide	Onoff Notion O-R 2014 T6 Alloy 2D forged. 31.6mm, 400mm length.
Saddle	Mondraker Vantage RR exclusive design	Mondraker Vantage R exclusive design	Mondraker Vantage exclusive design
Front Tire	Maxxis High Roller II 27,5x2.3 Tubeless Ready, Dual compound, Exo, 60TPI	Maxxis Ardent 27,5x2.40, Single compound, 60 TPI, Wire	Kenda Honey Badger 27,5x2.20, single compound, 30 TPI, Wire
Rear Tire	Maxxis High Roller II 27,5x2.3 Tubeless Ready, Dual compound, Exo, 60TPI	Maxxis Ardent 27,5x2.40, Single compound, 60 TPI, Wire	Kenda Honey Badger 27,5x2.20, single compound, 30 TPI, Wire
Tubes/Sealant	-	-	-
Front Hub	Mavic Boost axle 15x110mm, sealed bearings, IS 6 bolts mount	MDK DC511 15x110mm, sealed bearings, IS 6 bolts mount.	MDK-EP1, 9mm QR axle, cup & cone ball bearings, IS 6 bolts
Rear Hub	Mavic, Boost axle 12x148mm, sealed bearings, TS-2 freehub, IS 6 bolts	MDK GW 12x148mm, sealed bearings, IS 6 bolts mount.	MDK-EP1, 9mm QR axle, cup & cone ball bearings, IS 6 bolts
Rim	Mavic XA 27,5, Tubeless Ready, internal width 25mm, asymmetrical rim	MDK-EP1 27,5 TLR ASY, internal width 27mm, tubeless ready	MDK-EP1 27,5, 24mm external width, 32 spokes
Spokes	Mavic Steel, straight-pull	CN round stainless steel	CN round stainless steel
Weight	12,4 Kg	12,8 Kg	ND
Prezzo telaio	€699,00	-	-
Prezzo bici	€2.699,00	€1.999,00	€1.249,00

FACTOR

Meno escursione = più divertimento
Per alcuni questa equazione è quanto mai vera e allora Mondraker risponde con una bici all'altezza della situazione.

La Mondraker Factor, con un telaio in lega leggera 6061, sospensione Zero, Forward Geometry, 120 mm di corsa e un angolo di sterzo da 67°, concretizza questo concetto.

Divertimento (tanto) senza portare con sé troppi millimetri di travel e troppo peso.

Se vi piace guidare e se amate il supporto di una sospensione posteriore, allora la Mondraker Factor è un gran bel pezzo di mountainbike...

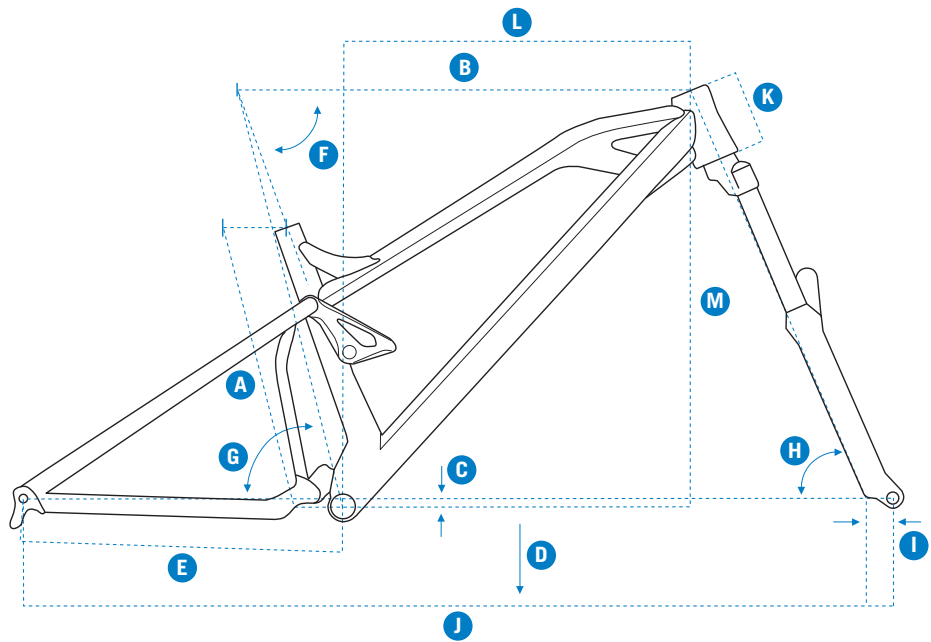

GEOMETRIA

	S	M	L	XL
A Seat Tube Length	380mm	420mm	470mm	510mm
B Top Tube Length	615mm	635mm	660mm	680mm
C Bottom Bracket Drop	-7mm	-7mm	-7mm	-7mm
D Bottom Bracket Height	342mm	342mm	342mm	342mm
E Chainstay Length	440mm	440mm	440mm	440mm
F Seat Tube Angle, Actual	69.5°	69.5°	69.5°	69.5°
G Seat Tube Angle, Effective	74°	74°	74°	74°
H Head Tube Angle	67°	67°	67°	67°
I Fork Offset	42mm	42mm	42mm	42mm
J Wheelbase	1175mm	1196mm	1222mm	1243mm
K Head Tube Length	100mm	110mm	120mm	130mm
L Reach	454mm	471mm	493mm	511mm
M Stack	561mm	570mm	579mm	588mm

CARATTERISTICHE

- 120 mm di escursione.
- Compatibile con ruote da 27,5".
- Telaio in lega leggera 6061 Alloy Stealth Evo.
- Mondraker Forward Geometry.
- Angolo di sterzo da 67°.
- Battuta mozzo posteriore 12x148 mm.
- Garanzia a vita sul telaio.
- Taglie: S, M, L, XL.
- Colore: Amber-Vibrant Blue-Black (Factor RR)
Navy-Flame Red-Light Blue (Factor R)
Black-Amber-Light Blue (Factor).





**FACTOR
RR**

**FACTOR
R**

FACTOR

Frame	Factor 27,5 6061 Alloy Stealth Evo + SAT hydroforming tubes	Factor 27,5 6061 Alloy Stealth Evo + SAT hydroforming tubes	Factor 27,5 6061 Alloy Stealth Evo + SAT hydroforming tubes
Shock	Fox Float DPS SV Performance	RockShox Monarch RT Solo Air	X-Fusion O2 Pro RL
Fork	Fox 34 27,5 Rhythm Sweep adjust EVOL, 130mm	RockShox Recon RL 27,5 Solo Air 130mm	RockShox 30 Silver 27,5 TK Solo Air 120mm
Headset	Onoff Saturn Tapered for 1-1/8" -> 1/5" head tube	Onoff Saturn Tapered for 1-1/8" -> 1/5" head tube	Onoff Saturn Tapered for 1-1/8" -> 1/5" head tube
R. Derailleur	Sram NX Type 3	Sram NX Type 3	SRAM GX, long cage
Chain	SRAM PC-1110 11s	SRAM PC-1110 11s	SRAM PC1031 10s
Shifters	Sram Trigger NX1, 11s	Sram Trigger NX1, 11s	Sram Trigger X5, 10s
Brakes	Sram Level T	Shimano M-315	Shimano M-315
Rotors	Sram Centerline 180 mm	Shimano 180 mm	Shimano 180 mm
Crankset	SRAM NX16000 series aluminium	SRAM NX16000 series aluminium	Suntour Zeron, AC4C Aluminum
Cassette	Sunrace CSMS8, 11-46T, 11s	Sunrace CSMS8, 11-46T, 11s	Sunrace CSMCS3, 11-42T, 10s
Handlebar	Onoff Notion 1.0. Aluminium 6061 double-Tapered	Onoff Notion 1.0. Aluminium 6061 double-Tapered	Onoff Notion 1.0. Aluminium 6061 double-Tapered
Stem	Onoff Stoic FG 30mm. 6061 forged aluminium. 31.8mm barbore	Onoff Stoic FG 30mm. 6061 forged aluminium. 31.8mm barbore	Onoff Stoic FG 30mm. 6061 forged aluminium. 31.8mm barbore
Grips	Onoff Diamond, 1lock-on, 130mm	Onoff Diamond, 1lock-on, 130mm	Onoff Diamond, 1lock-on, 130mm
Seatpost	Onoff Pija Dropper 31.6mm, internal hose guide.	Onoff Pija Dropper 31.6mm, internal hose guide.	Onoff Notion O-R. 2D forged head 2014 T6 aluminium
Saddle	Mondraker Factor RR 27,5 exclusive design	Mondraker Factor R 27,5 exclusive design	Mondraker Factor 27,5 exclusive design
Front Tire	Maxxis Ardent 27,5x2.4 Tubeless Ready, Dual compound, Exo, 60TPI	Maxxis Ardent 27,5x2.4 Tubeless Ready, Dual compound, Exo, 60TPI	Maxxis Ardent 27,5x2.4 Tubeless Ready, Dual compound, Exo, 60TPI
Rear Tire	Maxxis Ardent 27,5x2.4 Tubeless Ready, Dual compound, Exo, 60TPI	Maxxis Ardent 27,5x2.4 Tubeless Ready, Dual compound, Exo, 60TPI	Maxxis Ardent 27,5x2.4 Tubeless Ready, Dual compound, Exo, 60TPI
Tubes/Sealant	-	-	-
Front Hub	MDK DC511 15x110mm, sealed bearings, IS 6 bolts mount	MDK GW 15x110mm, sealed bearings, IS 6 bolts mount	MDK DC20, 9mm Qr axle, cup & cone ball bearing, IS 6 bolts
Rear Hub	MDK GW 12x148mm, sealed bearings, IS 6 bolts mount.	MDK GW 12x148mm, sealed bearings, IS 6 bolts mount	MDK DC22LW, 9mm Qr axle, cup & cone ball bearing, IS 6 bolts
Rim	MDK-EP1 27,5 TLR ASY, internal width 27mm, tubeless ready	MDK-EP1 27,5 TLR ASY, internal width 27mm, tubeless ready, 32 spokes	MDK-XP1 27,5, internal width 27mm, tubeless ready, 32 spokes
Spokes	CN round stainless steel	CN round stainless steel	CN round stainless steel
Weight	13,8 Kg	13,8 Kg	13,9 Kg
Prezzo bici	€3.199,00	€2.749,00	€2.199,00

PRIME +

Le ruote 650b Plus con sezione da 2,8" sono uno degli elementi che caratterizza di più la guida della Mondraker Prime +.

Tanto grip, tanto comfort e tanta facilità di guida per una hardtail con telaio in lega leggera che fa della maneggevolezza e della semplicità i suoi punti di forza. Grazie prima di tutto alla Forward Geometry, ad un angolo di sterzo da 69° e a un carro da 43,5 cm di lunghezza.

La Mondraker Prime + è una Mtb che si trova a metà strada fra il cross country e il trail riding: sta a te scegliere quale attitudine scegliere di questa bici.

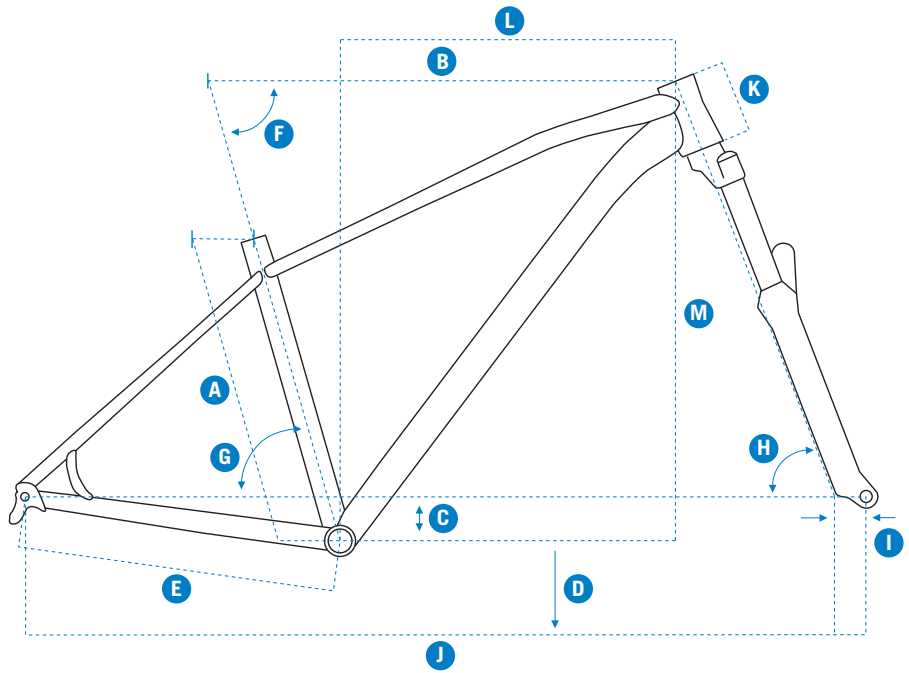

GEOMETRIA

	S	M	L	XL
A Seat Tube Length	390mm	430mm	470mm	510mm
B Top Tube Length	610mm	640mm	670mm	700mm
C Bottom Bracket Drop	-60mm	-60mm	-60mm	-60mm
D Bottom Bracket Height	305mm	305mm	305mm	305mm
E Chainstay Length	435mm	435mm	435mm	435mm
F Seat Tube Angle, Actual	74°	74°	74°	74°
G Seat Tube Angle, Effective	74°	74°	74°	74°
H Head Tube Angle	69°	69°	69°	69°
I Fork Offset	51mm	51mm	51mm	51mm
J Wheelbase	1133mm	1163mm	1194mm	1225mm
K Head Tube Length	90mm	100mm	110mm	120mm
L Reach	432mm	459mm	487mm	514mm
M Stack	620mm	630mm	639mm	648mm

CARATTERISTICHE

- Forcella da 120 mm di escursione.
- Angolo di sterzo da 69°.
- Compatibile con ruote da 27,5" Plus.
- Telaio in lega leggera 6061 Alloy Stealth Evo.
- Mondraker Forward Geometry.
- Battuta mozzo posteriore 12x148 mm.
- Garanzia a vita sul telaio.
- Taglie: S, M, L, XL.
- Colore: Yellow- Black (Prime R+) Orange-Black (Prime+).



PRIME
R+PRIME
+

Frame	Prime 27,5"+ 6061 Xtralite Alloy butted	Prime 27,5"+ 6061 Xtralite Alloy butted
Shock	-	-
Fork	RockShox Judy Gold 27,5+ RL Solo Air 120mm	RockShox Judy Silver TK 27,5+ Solo Air Solo Air 120mm
Headset	Onoff Saturn Tapered for 1-1/8" -> 1/5" head tube	Onoff Saturn Tapered for 1-1/8" -> 1/5" head tube
R. Derailleur	Sram NX Type 3	SRAM GX, long cage
Chain	SRAM PC-1110 11s	SRAM PC1031 10s
Shifters	Sram Trigger NX1	Sram Trigger X5, 10s
Brakes	Shimano MT500	Shimano M-365
Rotors	Shimano 180 mm	Shimano 180 mm
Crankset	SRAM NX16000 series aluminium	Suntour Zeron, AC4C Aluminum
Cassette	Sunrace CSM58, 11-46T, 11s	Sunrace CSMCS3, 11-42T, 10s
Handlebar	Mondraker aluminium 6061 double butted. Exclusive Prime R+ design	Mondraker aluminium 6061 double butted. Exclusive Prime R+ design
Stem	Onoff Stoic FG 30mm. Forged aluminium 6061, 31.8mm barbore	Onoff Stoic FG 30mm. Forged aluminium 6061, 31.8mm barbore
Grips	Onoff Wave, Kraton with gel, 130mm	Onoff Wave, Kraton with gel, 130mm
Seatpost	Onoff Pija Dropper 31.6mm, internal hose guide	Onoff Notion O-R. 2D forged head 2014 T6 aluminium. 31.6mm 400mm
Saddle	Mondraker Prime R+ exclusive design	Mondraker Prime R exclusive design
Front Tire	Kenda Havoc 27,5x2,80, tubeless ready, DTCEMC120 TPI	Kenda Havoc 27,5x2,80, tubeless ready, DTCEMC120 TPI
Rear Tire	Kenda Havoc 27,5x2,80, tubeless ready, DTCEMC120 TPI, foldable	Kenda Havoc 27,5x2,80, tubeless ready, DTCEMC120 TPI
Tubes/Sealant	-	-
Front Hub	MDK DC511 15x110mm, sealed bearings, IS 6 bolts mount	MDK DC511 15x110mm, sealed bearings, IS 6 bolts mount
Rear Hub	MDK GW 12x148mm, sealed bearings, IS 6 bolts mount	MDK GW 12x148mm, sealed bearings, IS 6 bolts mount
Rim	MDK-EP1 27,5 TLR ASY, internal width 35mm, tubeless ready	MDK-EP1 27,5 TLR ASY, internal width 35mm, tubeless ready
Spokes	CN round stainless steel	CN round stainless steel
Weight	13,1 Kg	13,1 Kg
Prezzo bici	€2.099,00	€1.549,00



PODIUM

La Mondraker Podium Carbon è una delle hardtail più originali ed efficaci nella scena delle Mtb da cross country. Ovvero è tipicamente Mondraker. Telaio in fibra di carbonio Stealth Air, Forward Geometry, attacco manubrio "integrato" nella linea del tubo superiore, ruote da 29" e standover molto basso per favorire la maneggevolezza.

La Podium Carbon nasce per un obiettivo molto chiaro: dare il meglio di sé in gara e assecondare i biker più esigenti e potenti. È proposta in 4 taglie e con allestimenti di alto livello. Pronti per correre?

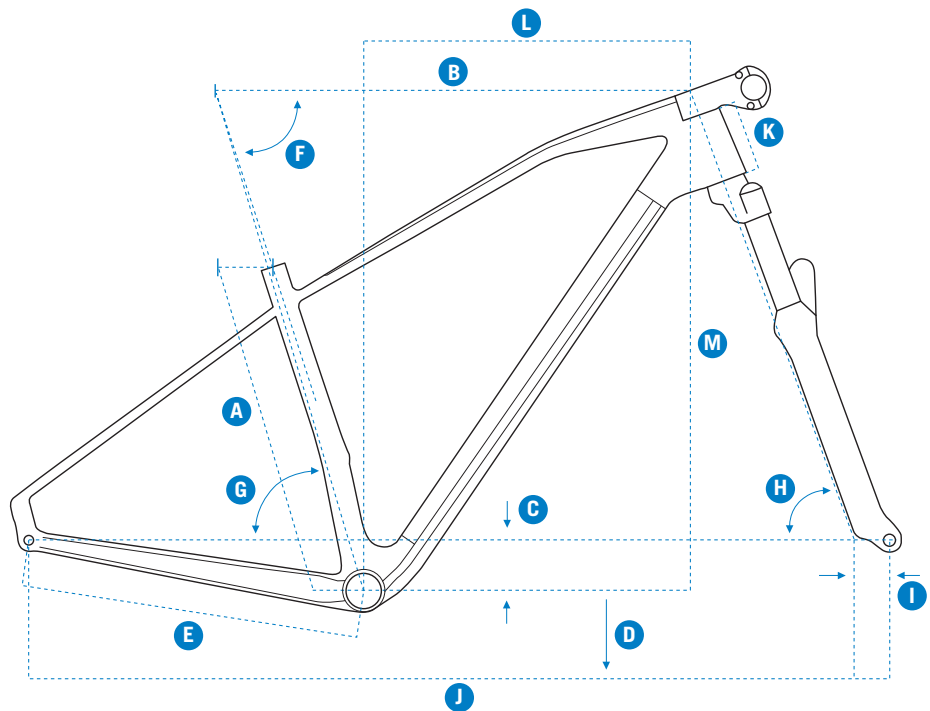

GEOMETRIA

	S	M	L	XL
A Seat Tube Length	395mm	430mm	470mm	520mm
B Top Tube Length	590mm	610mm	630mm	650mm
C Bottom Bracket Drop	-65mm	-65mm	-65mm	-65mm
D Bottom Bracket Height	300mm	300mm	300mm	300mm
E Chainstay Length	432mm	432mm	432mm	432mm
F Seat Tube Angle, Actual	72°	72°	72°	72°
G Seat Tube Angle, Effective	73.5°	73.5°	73.5°	73.5°
H Head Tube Angle	70°	70°	70°	70°
I Fork Offset	46mm	46mm	46mm	46mm
J Wheelbase	1086mm	1106mm	1127mm	1147mm
K Head Tube Length	85mm	90mm	100mm	115mm
L Reach	402mm	420mm	437mm	452mm
M Stack	637mm	642mm	651mm	666mm

CARATTERISTICHE

- Forcella da 100 mm di escursione.
- Angolo di sterzo da 70°.
- Compatibile solo con ruote da 29".
- Telaio in fibra di carbonio Mondraker Stealth Air.
- Mondraker Forward Geometry.
- Battuta mozzo posteriore 12x148 mm.
- Garanzia a vita sul telaio.
- Taglie: S, M, L, XL.
- Colore: Carbon-Light Blue-Flame Red (Podium Carbon RR 29)
Carbon-Flame Red-Amber (Podium Carbon R 29)
Carbon-Yellow-Light Blue (Podium Carbon 29).





PODIUM
CARBON RR 29

PODIUM
CARBON R 29

PODIUM
CARBON 29

	PODIUM CARBON RR 29	PODIUM CARBON R 29	PODIUM CARBON 29
Frame	Podium 29er Stealth Air Carbon	Podium 29er Stealth Air Carbon	Podium 29er Stealth Air Carbon
Shock	-	-	-
Fork	Fox 32 Step Cast Float 29 Factory, FIT4, EVOL, Boost axle, travel 100mm	Fox 32 Step Cast Float 29 Performance, GRIP, EVOL, travel 100 mm	RockShox SID 29 RL Solo Air 100mm
Headset	Onoff Titan internally Tapered for 1-1/8" -> 1/5" head tube	Onoff Titan internally Tapered for 1-1/8" -> 1/5" head tube	Onoff Titan internally Tapered for 1-1/8" -> 1/5" head tube
R. Derailleur	SRAM XX1 Eagle Type 3	SRAM X01 Eagle Type 3	Sram NX Type 3
Chain	SRAM GX Eagle 12s.	SRAM GX Eagle 12s	SRAM PC-1110 11s
Shifters	Sram Trigger XX1 Eagle 12s	Sram Trigger GX Eagle 12s	Sram Trigger NX1
Brakes	Sram Level TLM	Sram Level TLM	Sram Level T
Rotors	Sram Centerline 160 mm	Sram Centerline 160 mm	Sram Centerline 160 mm
Crankset	Rotor REX 1.1, CNC machined aluminium 7055	Rotor REX 2.1, CNC machined aluminium 7055	Truvativ Stylo 6k Eagle, 6000 series aluminium crank arms
Cassette	SRAM XG-1295 10-50T	SRAM XG-1275 10-50T	Sunrace CSMS8, 11-46T
Handlebar	Onoff Peak Carbon 0.2. 4.8mm rise, 710mm width	Onoff Peak Carbon 0.2. 4.8mm rise, 710mm width	Onoff Peak 0.2 710mm
Stem	Stealth Carbon Integrated	Stealth Carbon Integrated	Stealth Carbon Integrated
Grips	Onoff Diamond, 1lock-on, 130mm	Onoff Diamond, 1lock-on, 130mm	Onoff Diamond, 1lock-on, 130mm
Seatpost	Onoff Peak Carbon 0-R. 27.2mm. Diameter. 400mm length	Onoff Peak Carbon 0-R. 27.2mm. Diameter. 400mm length	Onoff Peak 0-R. Aluminium 7075. 27.2mm diameter
Saddle	Fizik Antares R5 K:IUM	Fizik Antares R7	Exclusive Mondraker Podium 29er design
Front Tire	Maxxis Ikon 3CMaxx Speed TR 29x2.20, tubeless ready, double compound	Maxxis Ikon 3CMaxx Speed TR 29x2.20, tubeless ready, double compound	Maxxis Ikon 3CMaxx Speed TR 29x2.20, tubeless ready, double compound
Rear Tire	Maxxis Ikon 3CMaxx Speed TR 29x2.20, tubeless ready, double compound	Maxxis Ikon 3CMaxx Speed TR 29x2.20, tubeless ready, double compound	Maxxis Ikon 3CMaxx Speed TR 29x2.20, tubeless ready, double compound
Tubes/Sealant	-	-	-
Front Hub	Mavic, Boost 15x110mm axle	Mavic, Boost 15x110mm axle	Mavic, Boost 15x110mm axle
Rear Hub	Mavic, Boost 12x148mm axle, sealed bearings	Mavic, Boost 12x148mm axle, sealed bearings	Mavic, Boost 12x148mm axle, sealed bearings
Rim	Mavic Crossmax Elite 29	Mavic Crossmax Light 29	Mavic Crossmax 29
Spokes	Mavic steel, straight pull, profiled, double butted	Mavic steel, straight pull, profiled, double butted	Mavic steel, straight pull, profiled, double butted
Weight	8.9 Kg	9,2 Kg	10,1 Kg
Prezzo telaio	€ 1.999,00	-	-
Prezzo bici	€ 6.399,00	€ 4.999,00	€ 3.499,00

CHRONO CARBON

Se la Mondraker Podium Carbon è una macchina da competizione Xc pura, la Mondraker Chrono Carbon è il mezzo adatto per chi predilige le marathon, le lunghe percorrenze e cerca un assetto più confortevole. Rispetto alla Podium il reach è leggermente inferiore e lo stack è maggiore, favorendo una postura più eretta e una maggiore facilità nella guida.

Il telaio è in fibra di carbonio Stealth 2.0 senza la Forward Geometry proprio per favorire chi ha meno esperienza nella guida. Meno leggerezza, ma prezzi più facilmente abbordabili.

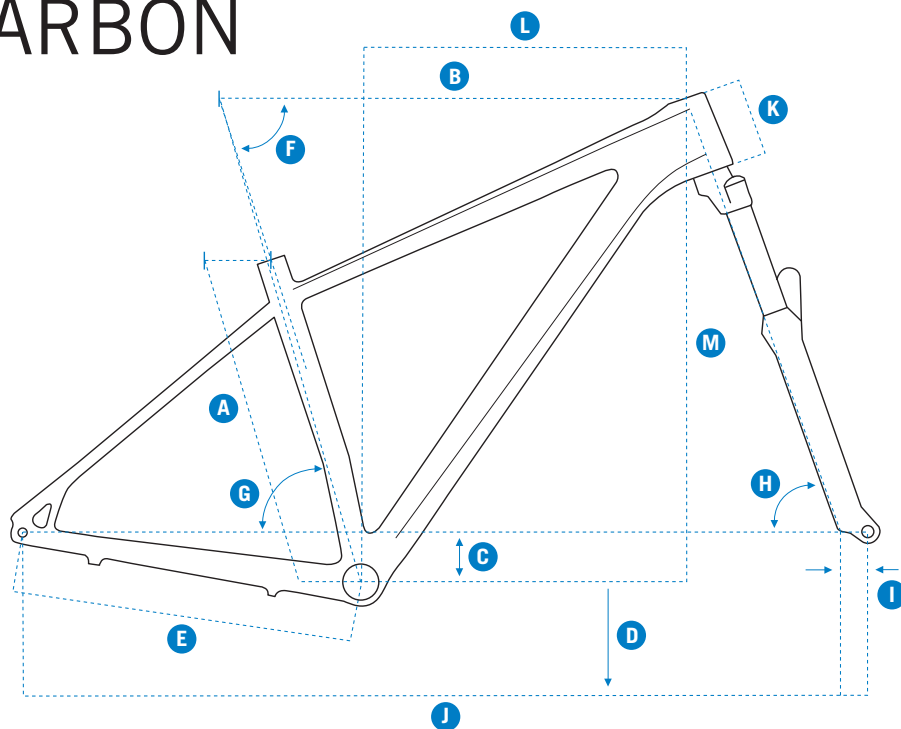

GEOMETRIA

	M	L	XL
A Seat Tube Length	430mm	480mm	520mm
B Top Tube Length	600mm	620mm	640mm
C Bottom Bracket Drop	-65mm	-65mm	-65mm
D Bottom Bracket Height	300mm	300mm	300mm
E Chainstay Length	438mm	438mm	438mm
F Seat Tube Angle, Actual	72°	72°	72°
G Seat Tube Angle, Effective	73.5°	73.5°	73.5°
H Head Tube Angle	70,5°	70,5°	70,5°
I Fork Offset	46mm	46mm	46mm
J Wheelbase	1097mm	1118mm	1140mm
K Head Tube Length	100mm	110mm	125mm
L Reach	416mm	433mm	447mm
M Stack	621mm	640mm	659mm

CARATTERISTICHE

- Forcella da 100 mm di escursione.
- Angolo di sterzo da 70,5°.
- Compatibile solo con ruote da 29".
- Telaio in fibra di carbonio Mondraker Stealth 2.0.
- Battuta mozzo posteriore 12x148 mm.
- Garanzia a vita sul telaio.
- Taglie: M, L, XL.
- Colore: Carbon-Light Blue-Flame Red (Chrono Carbon R 29)
Black Phantom (Chrono Carbon 29).





CHRONO CARBON
R 29

CHRONO CARBON
29

Frame	Chrono 29er Stealth 2.0 Carbon, PF30 bottom bracket,	Chrono 29er Stealth 2.0 Carbon, PF30 bottom bracket,
Shock	-	-
Fork	RockShox SID 29 RL Solo Air 100mm	RockShox Judy Gold 29 RL Solo Air 100mm
Headset	Onoff Titan internally Tapered for 1-1/8" -> 1/5" head tube	Onoff Titan internally Tapered for 1-1/8" -> 1/5" head tube
R. Derailleur	Sram GX Eagle Type 3	Sram GX Eagle Type 3
Chain	SRAM GX Eagle 12s.	SRAM GX Eagle 12s.
Shifters	Sram Trigger GX Eagle 12s	Sram Trigger GX Eagle 12s
Brakes	Sram Level T	Sram Level T
Rotors	Sram Centerline 160 mm	Sram Centerline 160 mm
Crankset	Truativ Stylo 6k Eagle, 6000 series aluminium crank arms	Truativ Stylo 6k Eagle, 6000 series aluminium crank arms
Cassette	SRAM XG-1275 10-50T	SRAM XG-1275 10-50T
Handlebar	Onoff Notion 0.2. Aluminium 6061 T6 double butted	Onoff Notion 0.2. Aluminium 6061 T6 double butted
Stem	Onoff Notion. 3D forged 6061 T6 aluminium	Onoff Notion. 3D forged 6061 T6 aluminium
Grips	Onoff Diamond, 1lock-on, 130mm	Onoff Diamond, 1lock-on, 130mm
Seatpost	Onoff Notion 0-R. Forged head 2014 T6 aluminium. 31.6mm, 400mm	Onoff Notion 0-R. Forged head 2014 T6 aluminium. 31.6mm, 400mm
Saddle	Exclusive Mondraker XC Chrono 29er design	Exclusive Mondraker XC Chrono 29er design
Front Tire	Maxxis Ikon Exo 29x2.35, 60 TPI	Maxxis Ikon Exo 29x2.35, 60 TPI
Rear Tire	Maxxis Ikon Exo 29x2.35, 60 TPI	Maxxis Ikon Exo 29x2.35, 60 TPI
Tubes/Sealant	-	-
Front Hub	Mavic, Boost 15x110mm axle	MDK-XP1 rotor, 15x100mm axle
Rear Hub	Mavic, Boost 12x142mm axle	MDK-XP1 rotor, 12x142mm axle,
Rim	Mavic Crossmax 29	MDK-XP1 29", 24mm external width, tubeless ready, 32 spokes
Spokes	Mavic steel, straight pull	CN stainless steel round
Weight	10,7 Kg	11,2 Kg
Prezzo telaio	-	-
Prezzo bici	€2.999,00	€2.599,00



LEADER

Telaio in lega leggera 6061 Xtralite, posizione in sella ispirata a quella della Mondraker Chrono e un listino prezzi più facile rendono la Mondraker Leader una gamma di hardtail molto interessanti per chi sta iniziando a impegnarsi un po' più seriamente sui pedali. Chi ama le lunghe percorrenze e cerca un mezzo affidabile e facile da guidare troverà nella Leader una proposta molto valida. Con la Mondraker Avant Geometry la posizione in sella è più comoda e il livello tecnico dei componenti scelti permette comunque di togliersi qualche soddisfazione. Sia in gara che lontano dalle gare.

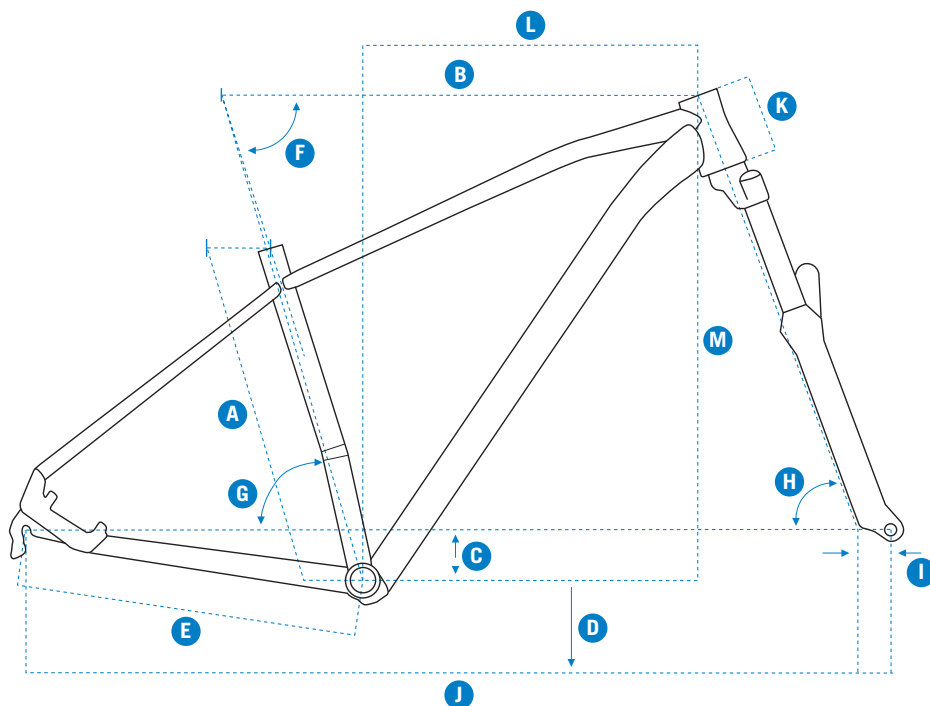

GEOMETRIA

	S	M	L	XL
A Seat Tube Length	395mm	440mm	480mm	520mm
B Top Tube Length	590mm	610mm	630mm	650mm
C Bottom Bracket Drop	-65mm	-65mm	-65mm	-65mm
D Bottom Bracket Height	300mm	300mm	300mm	300mm
E Chainstay Length	435mm	435mm	435mm	435mm,5
F Seat Tube Angle, Actual	72,5°	72,5°	72,5°	72,5°
G Seat Tube Angle, Effective	73.5°	73.5°	73.5°	73.5°
H Head Tube Angle	70°	70°	70°	70°
I Fork Offset	46mm	46mm	46mm	46mm
J Wheelbase	1087mm	1107mm	1127mm	1148mm
K Head Tube Length	100mm	100mm	110mm	125mm
L Reach	406mm	426mm	444mm	460mm
M Stack	618mm	618mm	628mm	642mm

CARATTERISTICHE

- Forcella da 100 mm di escursione.
- Angolo di sterzo da 70°.
- Compatibile solo con ruote da 29".
- Mondraker Avant Geometry.
- Telaio Mondraker Leader 29er 6061 Xtralite Alloy butted.
- Perno passante anteriore 15x100 mm.
- Garanzia a vita sul telaio.
- Taglie: S, M, L, XL.
- Colori: Amber-Black (Leader RR29)
Navy-Orange-Yellow (Leader R29)
Light Blue-Black-Flame Red (Leader S29)
Black-White-Flame Red (Leader 29).



LEADER
RR 29LEADER
R 29LEADER
S 29LEADER
29

	LEADER RR 29	LEADER R 29	LEADER S 29	LEADER 29
Frame	Leader 29er 6061 Xtralite Alloy butted, Avant Geometry	Leader 29er 6061 Xtralite Alloy butted, Avant Geometry	Leader 29er 6061 Xtralite Alloy butted, Avant Geometry	Leader 29er 6061 Xtralite Alloy butted, Avant Geometry
Shock	-	-	-	-
Fork	RockShox SID 29 RL Solo Air 100mm			
Headset	Onoff Saturn Tapered for 1-1/8" -> 1/5" head tube	Onoff Saturn Tapered for 1-1/8" -> 1/5" head tube	Onoff Saturn Tapered for 1-1/8" -> 1/5" head tube	Onoff Saturn Tapered for 1-1/8" -> 1/5" head tube
R. Deraillieur	Sram NX Type 3	Sram NX Type 3	Shimano XT RD-M781	Shimano SLX RD-M670 SGS Shadow
Chain	Sram PC-1110 11s	Sram PC-1110 11s	KMC X10 10s	KMC X11
Shifters	Sram Trigger XX1, 11s	Sram Trigger NX1	Shimano Deore SL-M6000 2x10s	Shimano Deore SL-M6000 2x10s
Brakes	SRAM Level	Shimano M-365	Shimano M-315	Tektro HDM285
Rotors	Sram Centerline 160 mm	Shimano 160 mm	Shimano 160 mm	Tektro 160 mm
Crankset	Race Face Aeffect SL, 6000 aluminium	SRAM NX16000 series aluminium	Suntour XCM 2x10s	Suntour XCM 2x10s
Cassette	Sunrace CSMS8, 11-46T	Sunrace CSMS8, 11-46T	SunRace CSMS, 11-36T 10s	SunRace CSMS, 11-36T 10s
Handlebar	Onoff Notion 0.2. Aluminium 6061 T6 double butted	Onoff Notion 0.2. Aluminium 6061 T6 double butted	Onoff Notion 0.2. Aluminium 6061 T6 double butted	MDK XC 0.2 Aluminium 6061 T6 double butted
Stem	Onoff Notion. Aluminium 6061-T6 3D-molded	Onoff Notion. Aluminium 6061-T6 3D-molded	Onoff Notion. Aluminium 6061-T6 3D-molded	MDK XC. Molded aluminium, angle +/-7°
Grips	Onoff Diamond, 1lock-on, 130mm	Onoff Diamond, 1lock-on, 130mm	Onoff Diamond, 1lock-on, 130mm	Onoff Diamond, 130mm
Seatpost	Onoff Notion 0-R. 2D forged head 2014 T6 27.2 mm 400mm	Onoff Notion 0-R. 2D forged head 2014 T6 27.2 mm 400mm	Onoff Notion 0-R. 2D forged head 2014 T6 27.2 mm 400mm	MDK XC. 6061 T6 aluminium casting. 27.2mm diameter
Saddle	Selle Royal with exclusive desing for Mondraker Leader	Selle Royal with exclusive desing for Mondraker Leader	Selle Royal with exclusive desing for Mondraker Leader	Selle Royal with exclusive desing for Mondraker Leader
Front Tire	Maxxis Ikon Exo 29x2.35, 60 TPI	Maxxis Ikon Exo 29x2.35, 60 TPI	Kenda Slant Six 29x2.35 single compound, 30TPI, wire	Kenda Slant Six 29x2.35 single compound, 30TPI, wire
Rear Tire	Maxxis Ikon Exo 29x2.35, 60 TPI	Maxxis Ikon Exo 29x2.35, 60 TPI	Kenda Slant Six 29x2.35 single compound, 30TPI, wire	Kenda Slant Six 29x2.35 single compound, 30TPI, wire
Tubes/Sealant	-	-	-	-
Front Hub	MDK-XP1, 15mm axle	MDK-XP1, 15mm axle	MDK-XP1, 15mm axle	MDK-XP1, 9 mm axle
Rear Hub	MDK-XP1, 9mm QR axle	MDK-XP1, 9mm QR axle	MDK-XP1, 9mm QR axle	MDK-XP1, 9mm QR axle
Rim	MDK-XP1 29", 21mm internal width	MDK-XP1 29", 21mm internal width	MDK-XP1 29", 24mm external width, tubeless ready, 32 spokes	MDK-XP1 29", 24mm external width, tubeless ready, 32 spokes
Spokes	CN stainless steel round	CN stainless steel round	CN stainless steel round	CN stainless steel round
Weight	11,8 Kg	12,4 Kg	-	13,9 Kg
Prezzo bici	€ 1.799,00	€ 1.349,00	€ 1.249,00	€ 1.049,00

PHASE

La gamma Mondraker Phase con ruote da 27,5" o da 29" è rivolta ai nuovi biker. Se volete scoprire il mondo della Mtb iniziando con un mezzo di facile utilizzo e con un costo contenuto, allora la Mondraker Phase fa per voi. Il telaio è in lega leggera Custolite a triplo spessore con la Mondraker Avant Geometry per un assetto in sella orientato verso la comodità e la facilità di guida. I due allestimenti previsti nel catalogo richiedono un esborso contenuto e prevedono componenti affidabili e con poche regolazioni. Se volete iniziare, con la Mondraker Phase siete sulla strada giusta.

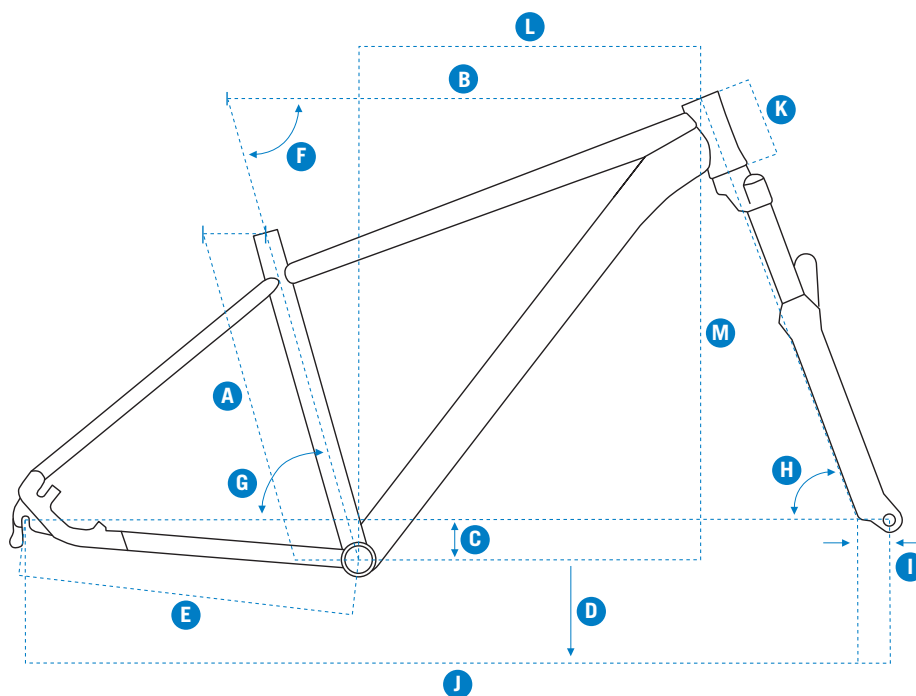

GEOMETRIA

	S	M	L	XL
A Seat Tube Length	380mm	430mm	480mm	530mm
B Top Tube Length	575mm	600mm	620mm	640mm
C Bottom Bracket Drop	-50mm	-50mm	-50mm	-50mm
D Bottom Bracket Height	300mm	300mm	300mm	300mm
E Chainstay Length	425mm	425mm	425mm	425mm
F Seat Tube Angle, Actual	74°	74°	74°	74°
G Seat Tube Angle, Effective	74°	74°	74°	74°
H Head Tube Angle	68.5°	68.5°	68.5°	68.5°
I Fork Offset	42mm	42mm	42mm	42mm
J Wheelbase	1085mm	1110mm	1131mm	1153mm
K Head Tube Length	100mm	100mm	110mm	130mm
L Reach	407mm	432mm	450mm	464mm
M Stack	583mm	583mm	592mm	611mm

CARATTERISTICHE

- Forcella da 100 mm di escursione.
- Angolo di sterzo da 70°.
- Compatibile con ruote da 27,5" e da 29".
- Mondraker Avant Geometry.
- Telaio Mondraker Phase 27,5 6061 Custolite Alloy triple butted.
- Garanzia a vita sul telaio.
- Taglie: S, M, L, XL.
- Colore: Orange Yellow Black (Phase S 27.5)
Black-Flame Red-Amber (Phase 27.5)
Navy-Amber (Phase S 29)
Flame Red-Black (Phase 29).





	PHASE S 27.5	PHASE 27.5	PHASE S 29	PHASE 29
Frame	Phase 27,5 6061 Custolite Alloy triple butted	Phase 27,5 6061 Custolite Alloy triple butted	Phase 29er 6061 Custolite Alloy triple butted	Phase 27,5 6061 Custolite Alloy triple butted
Shock	-	-	-	-
Fork	Suntour XCM ATB RL 27,5 100mm	Suntour XCT HLO 27,5 100mm	Suntour XCM ATB RL 29 100mm	Suntour XCT ATB 29 100mm
Headset	CH 9280, Internal ZS, 44mm external diameter cups	CH 9280, Internal ZS, 44mm external diameter cups	FSA No. 10, Internal ZS, 44mm external diameter cup	FSA No. 10, Internal ZS, 44mm external diameter cup
R. Derailleur	Shimano Alivio RD-M4000 SGS, 9s	Shimano Acera RD-M3000 SGS, long cage 8s	Shimano Alivio RD-M4000 SGS, 9s	Shimano Acera RD-M3000 SGS, 9s
Chain	KMC Z99 9s	KMC Z99 8s	KMC Z99 9s	KMC Z99 8s
Shifters	Shimano Altus SL-M2000 3x9s	Shimano Altus SL-M2000 3x8s	Shimano Altus FD-M2000 Low clamp	Shimano Altus SL-M2000 3x8s
Brakes	Tektro hydraulic brake, with 2 fingers lever	Tektro HDM285 hydraulic	Tektro HDM285 hydraulic	Tektro HDM285 hydraulic
Rotors	Tektro 160 mm	Tektro 160 mm	Tektro 160 mm	Tektro 160 mm
Crankset	Shimano Altus FC-M2000, 3x9s crank arms	Suntour XCT T, 3x8s crank arms	Shimano Altus FC-M2000, 3x9s crank arms	Suntour XCT T, 3x8s crank arms
Cassette	SunRace CS-M90, 11-34T 9s	Sunrace CS-M55 11-32T 8s	SunRace CS-M90, 11-34T 9s	Sunrace CS-M55 11-32T 8s
Handlebar	MDK XC 0.5 Aluminium 6061 T6 double-Tapered	MDK XC 0.5 Aluminium 6061 T6 double-Tapered	MDK XC 0.2 Aluminium 6061 T6 double butted, 4,8mm rise	MDK XC 0.2 Aluminium 6061 T6 double butted, 4,8mm rise
Stem	MDK XC. Molded aluminium, angle +/-7°	MDK XC. Molded aluminium, angle +/-7°	MDK XC. Molded aluminium, angle +/-7°	MDK XC. Molded aluminium, angle +/-7°
Grips	Onoff Diamond, 130mm	Onoff Diamond, 130mm	Onoff Diamond, 130mm	Onoff Diamond, 130mm
Seatpost	MDK XC. 6061 T6 forged aluminium	MDK XC. 6061 T6 forged aluminium	MDK XC. 6061 T6 aluminium casting	MDK XC. 6061 T6 aluminium casting
Saddle	Exclusive Mondraker Phase 27,5 design	Exclusive Mondraker Phase 27,5 design	Exclusive Mondraker Phase 29er design	Exclusive Mondraker Phase 29er design
Front Tire	Kenda Slant Six 27,5x2.35 single compound, 30TPI	Kenda Slant Six 27,5x2.35 single compound, 30TPI	Kenda Slant Six 29x2.35 single compound, 30TPI	Kenda Slant Six 29x2.35 single compound, 30TPI
Rear Tire	Kenda Slant Six 27,5x2.35 single compound, 30TPI	Kenda Slant Six 27,5x2.35 single compound, 30TPI	Kenda Slant Six 29x2.35 single compound, 30TPI	Kenda Slant Six 29x2.35 single compound, 30TPI
Tubes/Sealant	-	-	-	-
Front Hub	MDK-XS1, 9mm QR axle	MDK-XS1, 9mm QR axle	MDK-XS1, 9mm QR axle	MDK-XS1, 9mm QR axle
Rear Hub	MDK-XS1, 9mm QR axle	MDK-XS1, 9mm QR axle	MDK-XS1, 9mm QR axle	MDK-XS1, 9mm QR axle
Rim	MDK-XS1 27,5, 24mm external width, 32 spokes	MDK-XS1 27,5, 24mm external width, 32 spokes	MDK-XS1 29", 24mm external width, 32 spokes	MDK-XS1 29", 24mm external width, 32 spokes
Spokes	Black stainless steel	Black stainless steel	Black stainless steel	Black stainless steel
Weight	14,2 Kg	14,3 Kg	14,4 Kg	14,5 Kg
Prezzo bici	€849,00	€749,00	€849,00	€749,00

NEVA

La mountain bike piace sempre di più anche alle ragazze.

Ed ecco la serie Mondraker Neva, pensata proprio per loro, con un telaio dal tubo superiore più inclinato e un tubo verticale più corto per accomodare anche chi ha una statura ridotta.

La Mondraker Neva, con telaio in lega leggera 6061 Custolite a triplo spessore e componenti specifici per chi è alle prime armi, permette di iniziare a usare la bici offroad con estrema facilità.

La Mondraker Avant Geometry e l'angolo di sterzo da 68,5° permettono stabilità e facilità nella guida.

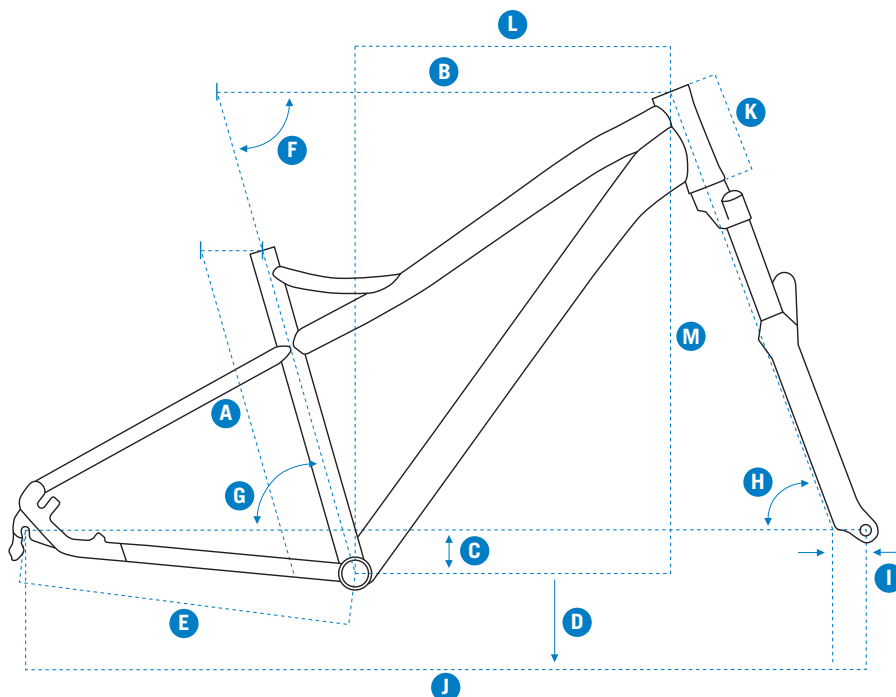

GEOMETRIA

	S	M	L	XL
A Seat Tube Length	330mm	380mm	430mm	480mm
B Top Tube Length	535mm	555mm	580mm	600mm
C Bottom Bracket Drop	-55mm	-55mm	-55mm	-55mm
D Bottom Bracket Height	300mm	300mm	300mm	300mm
E Chainstay Length	425mm	425mm	425mm	425mm
F Seat Tube Angle, Actual	74°	74°	74°	74°
G Seat Tube Angle, Effective	74°	74°	74°	74°
H Head Tube Angle	68.5°	68.5°	68.5°	68.5°
I Fork Offset	42mm	42mm	42mm	42mm
J Wheelbase	1042mm	1064mm	1090mm	1112mm
K Head Tube Length	100mm	120mm	130mm	140mm
L Reach	366mm	380mm	403mm	420mm
M Stack	588mm	607mm	616mm	626mm

CARATTERISTICHE

- Forcella da 100 mm di escursione.
- Telaio specifico per ragazze con tubo superiore più inclinato e piantone più corto.
- Angolo di sterzo da 68,5°.
- Compatibile con ruote da 27,5".
- Mondraker Avant Geometry.
- Telaio Mondraker Phase 27,5 6061 Custolite Alloy triple butted.
- Garanzia a vita sul telaio.
- Taglie: S, M, L, XL.
- Colore: Fuchsia-Amber-White (Neva S), Black-Light Blue-Fuchsia (Neva).



NEVA
S 27.5NEVA
27.5

	NEVA S 27.5	NEVA 27.5
Frame	Neva 27,5 6061 Custolite Alloy triple butted	Neva 27,5 6061 Custolite Alloy triple butted
Shock	-	-
Fork	Suntour XCM RL 27,5 100mm	Suntour XCM RL 27,5 100mm
Headset	CH 9280 Internal ZS,	CH 9280 Internal ZS,
R. Derailleur	Shimano Alivio RD-M4000 SGS, 9s	Shimano Acera RD-M3000 SGS, 8s
Chain	KMC Z99 9s	KMC Z99 8s
Shifters	Shimano Altus SL-M2000 3x9s	Shimano Altus SL-M2000 3x8s
Brakes	Tektro HDM286 hydraulic, 160mm 6-hole one-piece rotor	Tektro HDM286 hydraulic, 160mm 6-hole one-piece rotor
Rotors	Tektro 160 mm	Tektro 160 mm
Crankset	Shimano Altus FC-M2000, 3x9s crank arms	Suntour XCT T, 3x8s
Cassette	SunRace CS-M90, 11-34T 9s	Sunrace CS-M55 11-32T 8s
Handlebar	MDK XC 1.0 Aluminium 6061 T6 double butted	MDK XC 1.0 Aluminium 6061 T6 double butted
Stem	MDK XC. Molded aluminium, angle +/-7°, Diameter 31.8mm	MDK XC. Molded aluminium, angle +/-7°, Diameter 31.8mm
Grips	Onoff Ergo grip	Onoff Ergo grip
Seatpost	MDK XC. 6061 T6 forged aluminium. 27.2 diameter. 20mm setback	MDK XC. 6061 T6 forged aluminium. 27.2 diameter. 20mm setback
Saddle	Exclusive Mondraker Neva 27,5 design	Exclusive Mondraker Neva 27,5 design
Front Tire	Kenda Slant Six 27,5x2.35 single compound, 30TPI, wire	Kenda Slant Six 27,5x2.35 single compound, 30TPI, wire
Rear Tire	Kenda Slant Six 27,5x2.35 single compound, 30TPI, wire	Kenda Slant Six 27,5x2.35 single compound, 30TPI, wire
Tubes/Sealant	-	-
Front Hub	MDK-XS1, 9mm QR axle, cup & cone ball bearings, IS 6 bolts	MDK-XS1, 9mm QR axle, cup & cone ball bearings, IS 6 bolts
Rear Hub	MDK-XS1, 9mm QR axle, cup & cone ball bearings, IS 6 bolts	MDK-XS1, 9mm QR axle, cup & cone ball bearings, IS 6 bolts
Rim	MDK-XS1 27,5, 24mm external width, 32 spokes	MDK-XS1 27,5, 24mm external width, 32 spokes
Spokes	Black stainless steel	Black stainless steel
Weight	14,3 Kg	14,4 Kg
Prezzo bici	€849,00	€749,00



FACTOR KIDS

E arriviamo alle bici per i più giovani. Si comincia con la gamma Mondraker Factor, disponibile sia con ruote da 26 che da 24 pollici, con sospensione posteriore da 90 mm di escursione e una geometria ispirata ai modelli da grandi. La forcella ha 100 mm di corsa, la trasmissione Sram Gx è di tipo monocorona e di serie sono previsti i freni a disco con azionamento idraulico. La Mondraker Factor Kids è per chi vuole fare i primi passi nel mondo offroad con un certo stile. I prezzi sono identici per le due versioni: 2.299€ Pronti per partire?

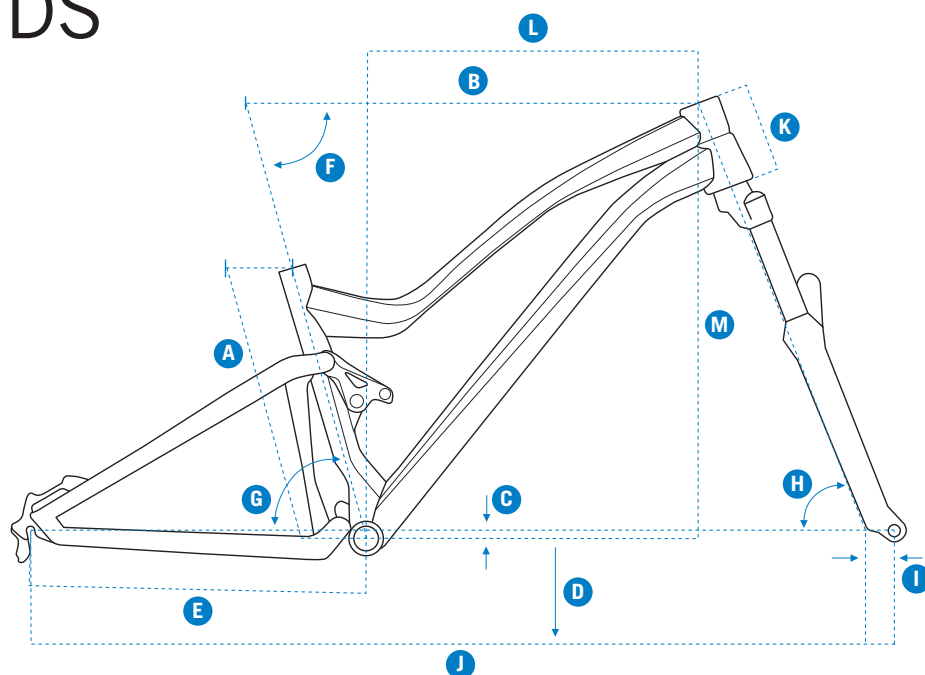

GEOMETRIA

	26"	24"
A Seat Tube Length	350mm	300mm
B Top Tube Length	570mm	525mm
C Bottom Bracket Drop	-10mm	-10mm
D Bottom Bracket Height	320mm	295mm
E Chainstay Length	420mm	420mm
F Seat Tube Angle, Actual	73°	73°
G Seat Tube Angle, Effective	74°	74°
H Head Tube Angle	69°	69°
I Fork Offset	39mm	39mm
J Wheelbase	1075mm	1028mm
K Head Tube Length	112mm	112mm
L Reach	414mm	374mm
M Stack	542mm	515mm

CARATTERISTICHE

- Sospensione Zero da 90 mm di escursione.
- Compatibile con ruote da 26 o 24 pollici.
- Telaio in lega leggera 6066 Alloy Stealth Evo.
- Angolo di sterzo da 69°.
- Garanzia a vita sul telaio.
- Colore: Light Blue-Black (Factor Kids 26"), Yellow-Black (Factor Kids 24").





FACTOR KIDS
26"

FACTOR KIDS
24"

Frame	Factor 26" 6066 Alloy Stealth Evo, hydroformed tubing	Factor 24" 6066 Alloy Stealth Evo, hydroformed tubing
Shock	RockShox Monarch R Solo Air. Settings: rebound. 152x31mm	RockShox Monarch R Solo Air. Settings: rebound. 152x31mm
Fork	RockShox 30Gold 26" TK Solo Air 100mm, Tapered head tube	RockShox 30Gold 26" TK Solo Air 80mm, Tapered head tube
Headset	Onoff Saturn Tapered for 1-1/8" -> 1/5" head tube	Onoff Saturn Tapered for 1-1/8" -> 1/5" head tube
R. Derailleur	SRAM GX, long cage, Exact actuation. 10s	SRAM GX, long cage, Exact actuation. 10s
Chain	SRAM PC-1031 10s	SRAM PC-1031 10s
Shifters	Sram Trigger X5, 1:1 Actuation	Sram Trigger X5, 1:1 Actuation
Brakes	Shimano MT-500 hydraulic, aluminium caliper, mineral oil resin pads	Shimano MT-500 hydraulic, aluminium caliper, mineral oil resin pads
Rotors	Shimano 160 mm	Shimano 160 mm
Crankset	SRAM NX16000 series aluminium, Direct Mount, 155mm crank arms.	SRAM GX1000 series aluminium, Direct Mount, 155mm crank arms.
Cassette	Sram PG-1020 11-36T 10s	Sram PG-1020 11-36T 10s
Handlebar	Onoff Notion 0.5 Aluminium 6061 double-Tapered, Height 12mm	Onoff Notion 0.5 Aluminium 6061 double-Tapered, Height 12mm
Stem	Onoff Stoic FG 30mm. Molded aluminium 6061, 31.8mm.	Onoff Stoic FG 30mm. Molded aluminium 6061, 31.8mm.
Grips	Onoff Diamond, 130mm	Onoff Diamond, 130mm
Seatpost	Onoff Notion 0-R. Aluminium 2014 T6 2D-molded head. Diameter 31.6mm	Onoff Notion 0-R. Aluminium 2014 T6 2D-molded head. Diameter 31.6mm
Saddle	SDG Fly JR	SDG Fly JR
Front Tire	Kenda Small Block Eight 26x2.35, DTC, 60TPI, folding	Kenda Small Block Eight 24x2.1, DTC, 60TPI, folding
Rear Tire	Kenda Small Block Eight 26x2.35, DTC, 60TPI, folding	Kenda Small Block Eight 24x2.1, DTC, 60TPI, folding
Tubes/Sealant	-	-
Front Hub	MDK DC20 9mm Qr axle, cup & cone ball bearing, IS 6 bolts mount	MDK DC20 9mm Qr axle, cup & cone ball bearing, IS 6 bolts mount
Rear Hub	MDK DC22LW 9mm Qr axle, cup & cone ball bearing, IS 6 bolts mount	MDK DC22LW 9mm Qr axle, cup & cone ball bearing, IS 6 bolts mount
Rim	MDK-XP1 26", internal width 24mm, 32 spokes	MDK-XP1 24", internal width 24mm, 32 spokes
Spokes	CN round stainless steel	CN round stainless steel
Weight	12,7 Kg	11,4 Kg
Prezzo bici	€2.299,00€	€2.299,00



PRIME KIDS

Lo stile è quello delle fatbike e le gomme Kenda da 2,8" di sezione parlano chiaro: la Mondraker Prime 20+ è una bici per i bambini che vogliono ripercorrere le orme dei papà biker. Il telaio è in lega leggera 7005 di grande solidità mentre la forcella è a steli dritti per una maggiore precisione di guida. L'allestimento per la versione con ruote da 20" è senza troppi fronzoli per contenere il prezzo di acquisto in 669€. È disponibile anche in versione con ruote da 24" al costo di 699€. Il telaio è in taglia unica e le ruote sono pronte per l'offroad.

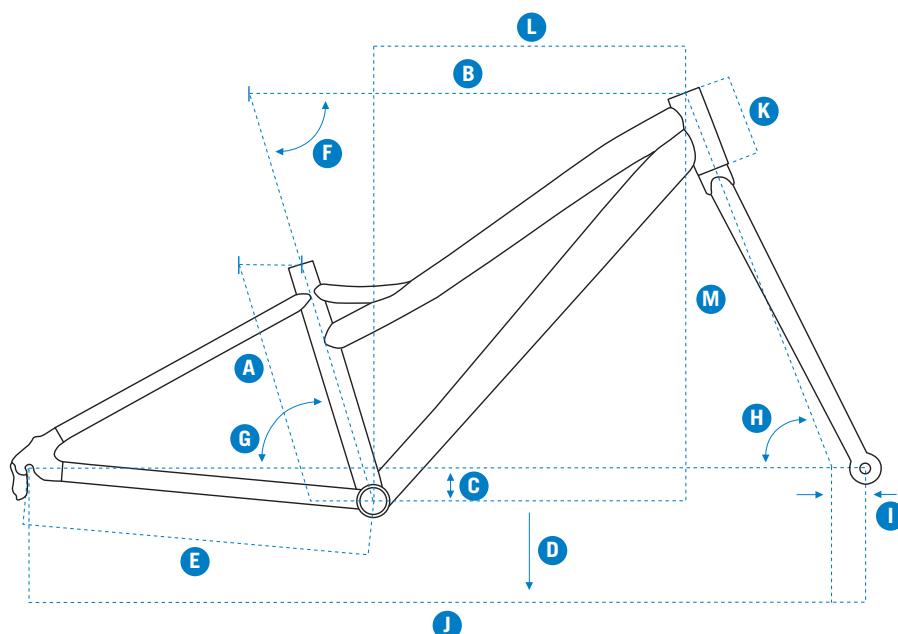

GEOMETRIA

20"

A Seat Tube Length	350mm
B Top Tube Length	570mm
C Bottom Bracket Drop	-10mm
D Bottom Bracket Height	320mm
E Chainstay Length	420mm
F Seat Tube Angle, Actual	73°
G Seat Tube Angle, Effective	74°
H Head Tube Angle	69°
I Fork Offset	39mm
J Wheelbase	1075mm
K Head Tube Length	112mm
L Reach	414mm
M Stack	542mm

CARATTERISTICHE

- Forcella lega leggera.
- Angolo di sterzo da 69°.
- Compatibile con ruote da 20" o da 24" (Prime 24+).
- Copertoni in stile fatbike da 2,8" di sezione.
- Telaio Mondraker Prime 20" 7005 Custolite alloy.
- Garanzia a vita sul telaio.
- Taglia unica.
- Colore: Flame Red-Navy-White (Prime 20+)
Navy-Orange-Yellow (Prime 24+).



PRIME KIDS 20+

Frame	Prime 20" 7005 Custolite alloy, internal headset, replaceable hanger
Shock	-
Fork	MDK Plus 20" Kid, aluminium bars and Chromoly head tube, Oversized bridge.
Headset	CH 9280 Aheadset 1-1/8" semi-integrated
R. Derailleur	Shimano RD-TX800 SGS 8s
Chain	KMC Z-72
Shifters	Shimano SL RS45, Revoshift
Brakes	Tektro Mechanical MD-300, 160mm, 6-hole one-piece rotor
Rotors	Tektro 160 mm
Crankset	ProWhell PRO, Length of crank arm 140mm
Cassette	Sunrace CS-M66 11-34T 8s
Handlebar	Mondraker double height 540x30mm
Stem	Mondraker XC 15x60mm
Grips	Black Diamond soft composite 75/102mm
Seatpost	Mondraker XC, Diameter 27.2mm, length 250mm
Saddle	Mondraker Prime Kids series
Front Tire	Kenda Slant Six 20x2.8, single compound, 30TPI, wire
Rear Tire	Kenda Slant Six 20x2.8, single compound, 30TPI, wire
Tubes/Sealant	-
Front Hub	Black aluminium formula cup & cone ball bearing, 32 spokes
Rear Hub	Black aluminium formula cup & cone ball bearing, 32 spokes
Rim	MDK Plus 20" internal width 30mm
Spokes	Stainless steel
Weight	10,8 Kg
Prezzo bici	€669,00



LEADER KIDS

La serie Mondraker Leader Kids è disponibile con ruote da 16, 20 o 24 pollici di diametro e si presta per iniziare a pedalare sia offroad che nei parchi cittadini.

La robustezza è la sua peculiarità grazie al telaio in lega leggera 7005 Custolite e ai componenti che privilegiano la solidità e il rapporto qualità/prezzo. È la gamma di bici di accesso nel mondo Mondraker per i più piccoli di età.

I prezzi oscillano fra 499€ e 399€ a seconda del modello.

Se volete che i vostri figli inizino con il piede giusto con la Mtb, adesso avete una soluzione ad hoc.

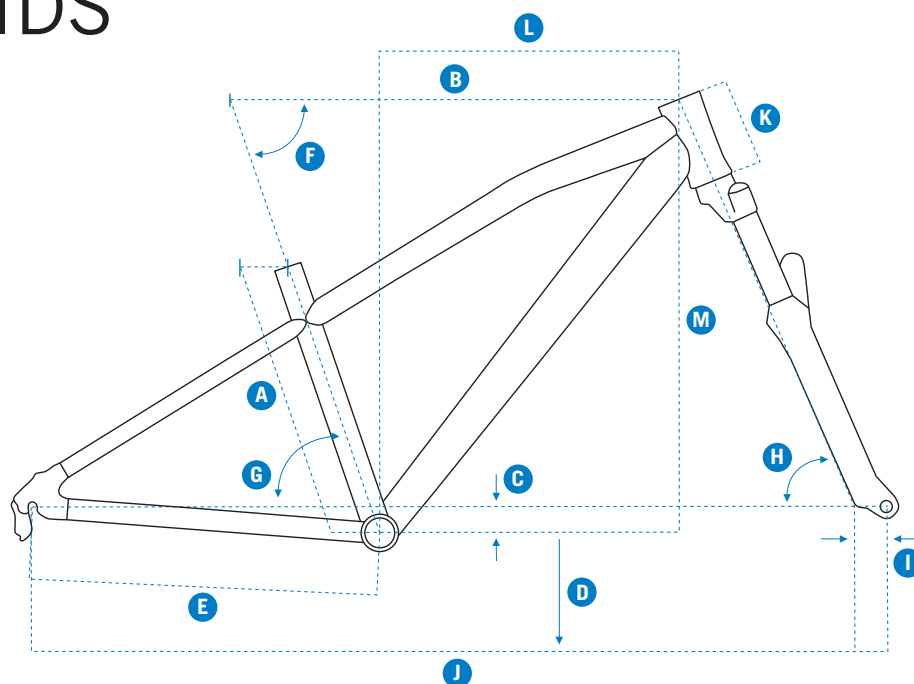

GEOMETRIA

	16"	20"	24"
A Seat Tube Length	350mm	260mm	320mm
B Top Tube Length	570mm	440mm	510mm
C Bottom Bracket Drop	-10mm	-15mm	-30mm
D Bottom Bracket Height	320mm	240mm	280mm
E Chainstay Length	420mm	350mm	395mm
F Seat Tube Angle, Actual	73°	71°	71°
G Seat Tube Angle, Effective	74°	71°	71°
H Head Tube Angle	69°	68°	68°
I Fork Offset	39mm	45mm	40mm
J Wheelbase	1075mm	855mm	964mm
K Head Tube Length	112mm	100mm	100mm
L Reach	414mm	307mm	340mm
M Stack	542mm	385mm	495mm

CARATTERISTICHE

- Forcella ammortizzata.
- Angolo di sterzo da 69°-68°.
- Compatibile con ruote da 16, 20 o 24 pollici.
- Trasmissione monocorona.
- Telaio Mondraker Leader 7005 Custolite alloy.
- Garanzia a vita sul telaio.
- Taglie uniche.
- Colore: Flame Red-Navy, Fuchsia-White-Light Blue (Leader 16)
Orange-Black-Yellow, Light Blue-White (Leader 20)
Black-Amber-Flame Red, Pearl White-Amber-Fuchsia (Leader 24).





LEADER KIDS 24"

LEADER KIDS 20"

LEADER KIDS 16"

	LEADER KIDS 24"	LEADER KIDS 20"	LEADER KIDS 16"
Frame	Leader 24" 7005 Custolite alloy, internal headset, replaceable hanger	Leader 20" 7005 Custolite alloy, internal headset, replaceable hanger	Leader 16" 7005 Custolite alloy, internal headset, replaceable hanger
Shock	-	-	-
Fork	Suntour M3010 50mm, 25mm stanchions, soft spring	MDK 20" Kid, Aluminium stanchions and Chromoly steering tube	MDK 16" Kid, Aluminium stanchions and Chromoly steering tube
Headset	CH 9280 Aheadset 1-1/8" semi-integrated	CH 9280 Aheadset 1-1/8"	CH 9280 Aheadset 1-1/8" semi-integrated
R. Derailleur	Shimano Altus RD-M310 8s	Shimano RD-TY300 short cage 6v	Shimano RD-TY300 short cage 6v
Chain	KCM Z-73	KCM Z-50	KCM Z-50
Shifters	Shimano SL RS45, Revoshift	Shimano SL RS35, Revoshift	Shimano SL RS35, Revoshift
Brakes	Tektro V-Brake Aluminium	Tektro V-Brake Aluminium	Tektro V-Brake Aluminium
Rotors	-	-	-
Crankset	Prowheel black steel 152mm crank length. 36T	Prowheel black steel 140mm crank length. 36T	Prowheel black steel 102mm crank length. 36T
Cassette	Sunrace CS-M66 11-34T 8s	Shimano MF-TZ20 14-28T 6s	Shimano MF-TZ20 14-28T 6s
Handlebar	Mondraker 580x30mm double height	Mondraker 560x30mm double height	Mondraker 450x20mm double height
Stem	Mondraker XC 15x60mm	Mondraker XC 15x60mm	Mondraker XC 15x40mm
Grips	86mm black diamond soft compound	75/102mm black diamond soft compound	75/102mm black diamond soft compound
Seatpost	Mondraker XC 27.2mm diameter, 300mm length	Mondraker XC 27.2mm diameter, 250mm length	Mondraker XC 27.2mm diameter, 250mm length
Saddle	Mondraker Leader Kids series	Mondraker Leader Kids series	Mondraker Finalist Kids series
Front Tire	Kenda Small Block Eight 24x2.10, DTC, 30TPI	Kenda Small Block Eight 20x2.10, DTC, 30TPI, wire	Kenda Kenda Kaos 16x2.10, single compound, 30TPI, wire.
Rear Tire	Kenda Small Block Eight 24x2.10, DTC, 30TPI	Kenda Small Block Eight 20x2.10, DTC, 30TPI, wire	Kenda Kenda Kaos 16x2.10, single compound, 30TPI, wire.
Tubes/Sealant	-	-	-
Front Hub	Black aluminium formula, cup & cone ball bearings, 32 spokes	Formula aluminium black, cup & cone ball bearings, 32 spokes	Formula aluminium black, cup & cone ball bearings, 32 spokes
Rear Hub	Black aluminium formula, cup & cone ball bearings, 32 spokes	Formula aluminium black, cup & cone ball bearings, 32 spokes	Formula aluminium black, cup & cone ball bearings, 32 spokes
Rim	MDK-24 black aluminium, AV valve, 32 spokes	MDK-20 black aluminium, AV valve, 32 spokes	MDK-16 black aluminium, AV valve, 32 spokes
Spokes	Black stainless steel	Black stainless steel	Black stainless steel
Weight	11,7 Kg	8,9 Kg	8,1 Kg
Prezzo bici	€499,00	€449,00	€399,00

YETI



★dsb★

SEMPLICEMENTE BICI



Con l'arrivo della sospensione Switch Infinity Yeti ha compiuto un altro grande passo in avanti per l'evoluzione della mountain bike.

Il marchio di Golden, Colorado, incarna lo spirito della Mtb come pochi altri al mondo e la gamma 2018, ulteriormente raffinata, ne è un chiaro esempio.

La loro proposta di trail bike è la più ampia e completa che esista, dalla Sb6 per l'enduro fino alla Sb4.5 per l'Xc e il trail riding, passando per la Beti, specifica per le ragazze. C'è da perdere la testa solo a guardarle le Yeti e non appena andate un po' più a fondo nella loro storia e non appena vi diranno delle loro prestazioni... beh, siate pronti.

SB6

Dalla bici da enduro di casa Yeti scordatevi escursioni super (siamo a 152 mm) e impostazioni di guida estreme. La Yeti Sb6 è una bici capace di comportarsi bene ovunque, in salita, nel pedalato e, ovviamente, anche in discesa.

È una bici per chi sa guidare perchè la rigidità del telaio asseconda bene chi sa osare in discesa.

E la sospensione Switch Infinity permette un'elevata rigidità torsionale ed ha un comportamento lineare.

Tre le tipologie di telaio: Team Replica (cioè il top), Turq Series e Carbon Series.

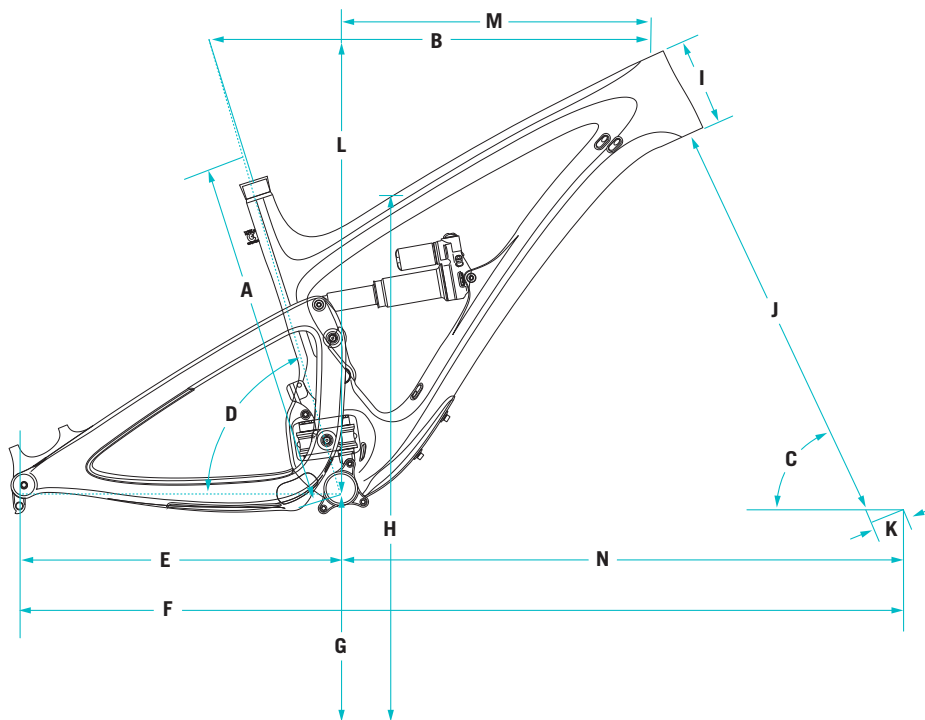

GEOMETRIA

(Forcella da 170 mm. Misure in mm)

	XS	SM	MD	LG	XL
A Seat Tube Length	381	419	445	483	521
B Toptube Length	555	581	608	634	659
C Headtube Angle °	65.0	65.1	65.1	65.1	65.1
D Eff. Seat Tube Angle °	73.1	73.0	72.9	72.8	72.7
E Chainstay Length	442	442	442	442	442
F Wheelbase	1138	1165	1192	1219	1247
G Estimated BB Height	349	349	349	349	349
H Standover	762	765	766	767	766
I Headtube Length	94	110	121	138	160
J Axle to Crown	559	559	559	559	559
K Offset	44	44	44	44	44
L Stack	578	593	604	619	639
M Reach	379	400	422	442	461
N Front Center	696	723	750	777	805

CARATTERISTICHE

- 152 mm di escursione Switch Infinity.
- Ruote da 27,5".
- Battuta Boost.
- Garanzia di 5 anni sul telaio.
- Perfetta per: sentieri aggressivi ed enduro racing.
- A suo agio su: terreni pieni di radici, rocciosi, tecnici.
- Taglie: XS, SM, MD, LG, XL
- Peso telaio: 2,83 kg Team Replica, 2,75 kg Turq Series, 3,01 kg Carbon Series.
- Colore: Tourquise, Black.



**SB6 T-Series
SHIMANO XT**
**SB6 T-Series
SRAM X01 EAGLE**
**SB6 T-Series
TEAM REPLICA**

Frame	T-Series	T-Series	T-Series
Fork	Fox Factory 36 160 27	Fox Factory 36 160 27	Fox Factory 36 Orange 170mm
Shock	Fox Factory	Fox Factory	Fox Factory DHX2 Air
Front Tire	Maxxis Minion DHF 2.5	Maxxis Minion DHF 2.5	Maxxis Minion DHF 2.5
Rear Tire	Maxxis Aggressor 2.3	Maxxis Aggressor 2.3	Maxxis Aggressor 2.3
Rear Rotor	Shimano SMTR66M	Sram Centerline 180	Shimano Frezza 180
Front Rotor	Shimano SMTR66M	Sram Centerline 180	Shimano Frezza 180
Headset	Cane Creek 40 Inset Taper	Cane Creek 40 Inset Taper	Chris King Inset Taper
Wheelset	DT Swiss 350 W/XM481	DT Swiss 350 W/XM481	DT Swiss XM1501 Spline 1 30mm
BB	Race Face BB92 30mm	Sram Gxp BB92	Shimano BB92
Tubes	Stans	Stans	-
Bar	Yeti 800x35 Turq	Yeti 800x35 Turq	Renthal Fatbar Carbon 35x800mm
Stem	Race Face Turbine Basic 50x35mm	Race Face Turbine Basic 50x35mm	Renthal Apex 35x50mm
Small	Small Parts Kit (4mm)	Small Parts Kit (4mm)	-
Crank	Race Face Turbine	Sram X01 Carbon 52mm	Shimano XTR 30T
Seat	WTB Custom Saddle	WTB Custom Saddle	Ergon SME3 Pro
Front Brake	Shimano XT	Sram Guide RSC	Shimano XTR
Rear Brake	Shimano XT	Sram Guide RSC	Shimano XTR
Rear Der	Shimano XT	Sram X01 Eagle	Shimano XTR
Cassette	Shimano XT 11-46	Sram 1275	Shimano XTR 11-40
Chain	Shimano SLX	Sram GX	Shimano XTR
Shift	Shimano XT	Sram X01 Eagle	Shimano XTR
Clamps/Adapt	N/A	Sram MMX/Left	-
Post	Fox Transfer	Fox Transfer	Fox Transfer Kashima
Prezzo telaio	€4.299,00	€4.299,00	-
Prezzo bici	€7.699,00	€8.299,00	€10.999,00





SB6 C-Series
SHIMANO XT/SLX

SB6 C-Series
SRAM GX EAGLE

	SB6 C-Series SHIMANO XT/SLX	SB6 C-Series SRAM GX EAGLE
Frame	C-Series	C-Series
Fork	Fox Performance 36 160 27	Fox Performance 36 160 27
Shock	Fox Performance	Fox Performance
Front Tire	Maxxis Minion DHF 2.5	Maxxis Minion DHF 2.5
Rear Tire	Maxxis Aggressor 2.3	Maxxis Aggressor 2.3
Rear Rotor	Shimano SMTR66M	Sram Centerline 180
Front Rotor	Shimano SMTR66M	Sram Centerline 180
Headset	Cane Creek 40 Inset Taper	Cane Creek 40 Inset Taper
Wheelset	DT Swiss E1900 Wheelset 27 6-Bolt Shim	DT Swiss E1900 Wheelset 27 6-Bolt Shim
BB	Race Face BB92 Shim	Sram Gxp BB92
Tubes	Stans	Stans
Bar	Race Face Respond 785	Race Face Respond 785
Stem	Race Face Respond 45	Race Face Respond 45
Small	Small Parts Kit (4mm)	Small Parts Kit (4mm)
Crank	Race Face Affect	Sram GX
Seat	WTB Custom Saddle	WTB Custom Saddle
Front Brake	Shimano SLX	Sram Guide R
Rear Brake	Shimano SLX	Sram Guide R
Rear Der	Shimano XT	Sram X01
Cassette	Shimano SLX KCSM7000146	Sram 1275
Chain	Shimano SLX	Sram GX Eagle
Shift	Shimano SLX	Sram GX Eagle
Clamps/Adapt	N/A	Sram MMX/Left
Post	Fox Transfer	Fox Transfer
Prezzo bici	€5.799,00	€6.399,00



SB5.5

Sì, le 29er sono cambiate e scordatevi definitivamente di tutti i pregiudizi che aleggiavano sulle “wagon wheels”.

La Yeti Sb5.5 è una trail bike di straordinaria capacità capace di districarsi con facilità anche sui tracciati enduro.

I 140 mm di escursione abbinati a ruote da 29” e a una geometria molto “disinvolta” permettono una guida precisa ed eccitante, specie con una forcella da 160 mm di escursione.

La Yeti Sb5.5 nasce per i sentieri più cattivi, per le Prove Speciali e per chi in bici cerca emozioni forti.

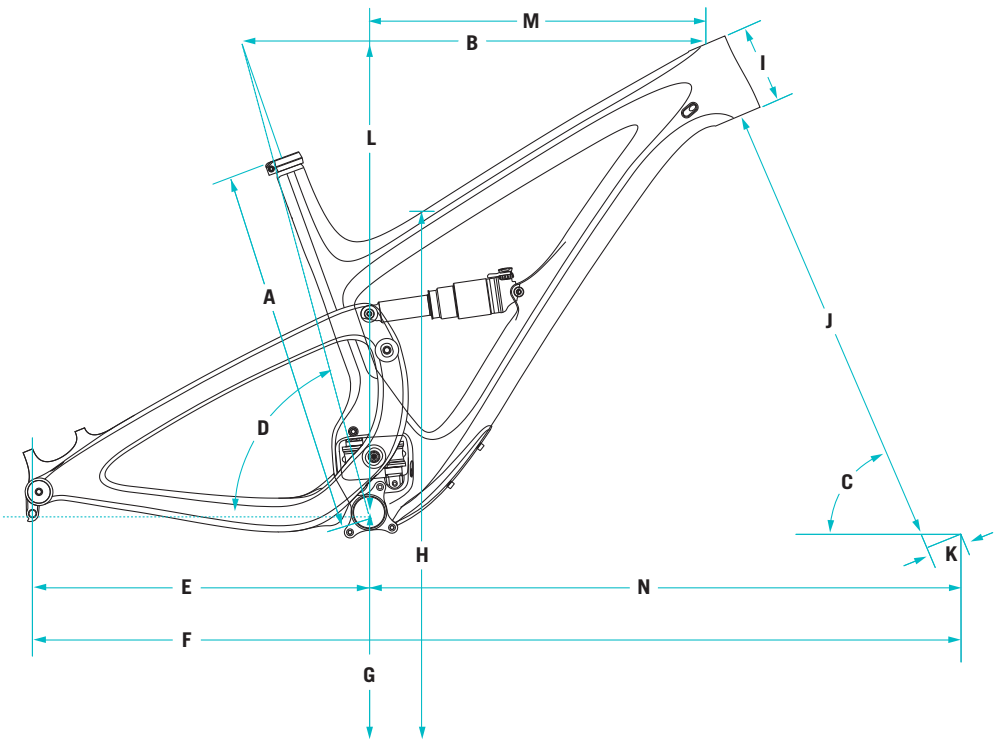

GEOMETRIA

(Forcella da 160 mm. Misure in mm)

	MD	LG	XL
A Seat Tube Length	445	483	521
B Toptube Length	601	626	652
C Headtube Angle °	66.5	66.5	66.5
D Eff. Seat Tube Angle °	73.6	73.6	73.6
E Chainstay Length	437	437	437
F Wheelbase	1168	1195	1222
G Estimated BB Height	346	346	346
H Standover	743	755	767
I Headtube Length	90	105	121
J Axle to Crown	567	567	567
K Offset	51	51	51
L Stack	610	624	639
M Reach	421	442	463
N Front Center	731	758	785

CARATTERISTICHE

- 140 mm di escursione Switch Infinity.
- Ruote da 29”.
- Battuta Boost.
- Garanzia di 5 anni sul telaio.
- Perfetta per: sentieri aggressivi e anche enduro.
- A suo agio su: terreni pieni di radici, rocciosi, tecnici.
- Taglie: MD, LG, XL.
- Peso telaio Turq Series: 2,57 kg.
- Peso telaio Carbon Series: 2,97 kg.
- Colore: Tourquise, Black.



**SB5.5 T-Series
SHIMANO XT**
**SB5.5 T-Series
SRAM X01 EAGLE**
**SB5.5 T-Series
SRAM XX1 EAGLE**

Frame	T-Series	T-Series	T-Series
Fork	Fox Factory 36 160 29	Fox Factory 36 160 29	Fox Factory 36 160 29
Shock	Fox Factory	Fox Factory	Fox Factory
Front Tire	Maxxis Minion DHF 2.5	Maxxis Minion DHF 2.5	Maxxis Minion DHF 2.5
Rear Tire	Maxxis Aggressor 2.3	Maxxis Aggressor 2.3	Maxxis Aggressor 2.3
Rear Rotor	Shimano SMTR66M	Sram Centerline 180	Sram Centerline 180
Front Rotor	Shimano SMTR66M	Sram Centerline 180	Sram Centerline 180
Headset	Cane Creek 40 Inset Taper	Cane Creek 40 Inset Taper	CHRIS KING
Wheelset	DT Swiss 350 W/XM481	DT Swiss 350 W/XM481	DT Swiss 350 W/XM481
BB	Race Face BB92 30mm	Sram Gxp BB92	Sram Gxp BB92
Tubes	Stans	Stans	Stans
Bar	Yeti 800x35 Turq	Yeti 800x35 Turq	Yeti 800x35 Turq
Stem	Race Face Turbine Basic 50x35mm	Race Face Turbine Basic 50x35mm	Race Face Turbine 50x35mm
Small	Small Parts Kit (4mm)	Small Parts Kit (4mm)	Small Parts Kit (4mm)
Crank	Race Face Turbine	Sram X01 Carbon 52mm	Sram X01 Carbon 52mm
Seat	WTB Custom Saddle	WTB Custom Saddle	Ergon
Front Brake	Shimano XT	Sram Guide RSC	Sram Guide RSC
Rear Brake	Shimano XT	Sram Guide RSC	Sram Guide RSC
Rear Der	Shimano XT	Sram X01 Eagle	Sram XX1 Eagle
Cassette	Shimano XT 11-46	Sram 1275	Sram 1299 Eagle Gold
Chain	Shimano SLX	Sram GX	Sram 1299 Eagle Gold
Shift	Shimano XT	Sram X01 Eagle	Sram XX1 Eagle
Clamps/Adapt	N/A	Sram MMX/Left	Sram MMX/Left
Post	Fox Transfer	Fox Transfer	Fox Transfer
Prezzo telaio	€4.299,00	€4.299,00	€4.299,00
Prezzo bici	€7.699,00	€8.299,00	€10.999,00

SB5.5 C-Series
SHIMANO XT/SLXSB5.5 C-Series
SRAM GX EAGLE

Frame	C-Series	C-Series
Fork	Fox Performance 36 160 27	Fox Performance 36 160 27
Shock	Fox Performance	Fox Performance
Front Tire	Maxxis Minion DHF 2.5	Maxxis Minion DHF 2.5
Rear Tire	Maxxis Aggressor 2.3	Maxxis Aggressor 2.3
Rear Rotor	Shimano SMTR66M	Sram Centerline 180
Front Rotor	Shimano SMTR66M	Sram Centerline 180
Headset	Cane Creek 40 Inset Taper	Cane Creek 40 Inset Taper
Wheelset	DT Swiss E1900 Wheelset 27 6-Bolt Shim	DT Swiss E1900 Wheelset 27 6-Bolt Shim
BB	Race Face BB92 Shim	Sram Gxp BB92
 Tubes	Stans	Stans
Bar	Race Face Respond 785	Race Face Respond 785
Stem	Race Face Respond 45	Race Face Respond 45
Small	Small Parts Kit (4mm)	Small Parts Kit (4mm)
Crank	Race Face Affect	Sram GX
Seat	WTB Custom Saddle	WTB Custom Saddle
Front Brake	Shimano SLX	Sram Guide R
Rear Brake	Shimano SLX	Sram Guide R
Rear Der	Shimano XT	Sram X01
Cassette	Shimano SLX KCSM7000146	Sram 1275
Chain	Shimano SLX	Sram GX Eagle
Shift	Shimano SLX	Sram GX Eagle
Clamps/Adapt	N/A	Sram MMX/Left
Post	Fox Transfer	Fox Transfer
Prezzo bici	€5.799,00	€6.399,00



SB5+

Le ruote 650b Plus hanno richiesto una modifica importante al disegno del carro: i foderi bassi sono rialzati in modo che la gomma Plus possa avere lo spazio necessario e affinché il carro rimanga su valori molto contenuti (43,7 cm) di lunghezza. Ed ecco la Yeti Sb5+, la prima trail bike della casa con travel di 127 mm specifica per le gomme Plus. L'obiettivo è arrivare a un livello di prestazioni che altre trail bike Plus non possono raggiungere. La sospensione Switch Infinity incrementa i livelli di trazione e rigidità. Insomma, scordatevi che trail bike Plus siano lente, goffe...

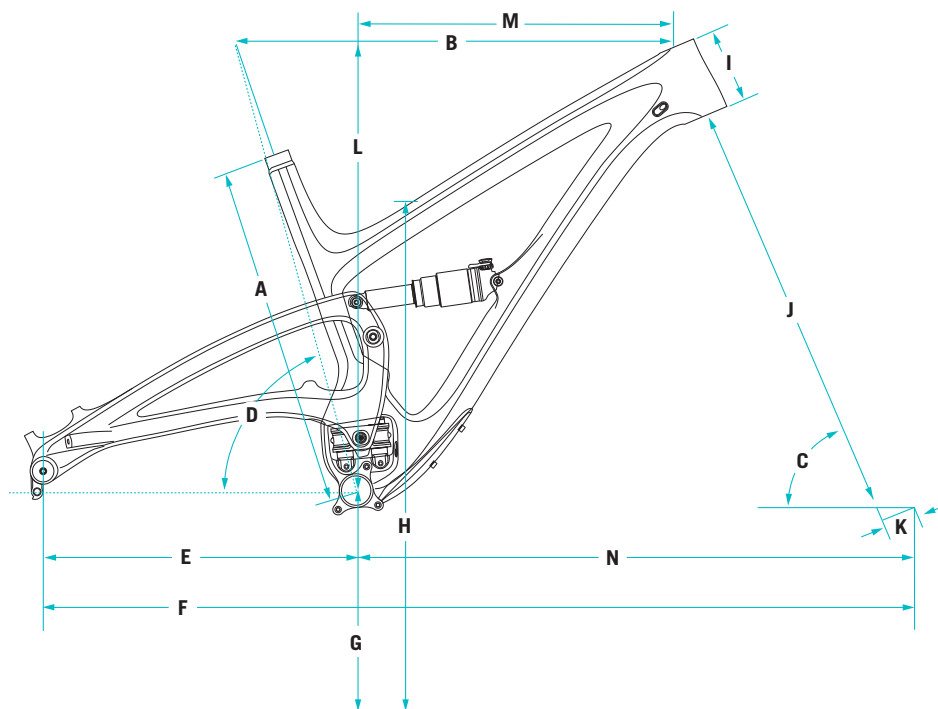

GEOMETRIA

(Forcella da 150 mm. Misure in mm)

	MD	LG	XL
A Seat Tube Length	445	483	521
B Toptube Length	601	625	650
C Headtube Angle °	66.5	67.1	67.1
D Eff. Seat Tube Angle °	73.6	74.1	74.1
E Chainstay Length	437	437	437
F Wheelbase	1168	1190	1218
G Estimated BB Height	346	331	331
H Standover	743	738	751
I Headtube Length	90	105	121
J Axle to Crown	567	556	556
K Offset	51	51	51
L Stack	610	620	634
M Reach	421	448	469
N Front Center	731	754	781

CARATTERISTICHE

- 127 mm di escursione Switch Infinity.
- Ruote 650b Plus.
- Battuta Boost.
- Garanzia di 5 anni sul telaio.
- Perfetta per: sentieri aggressivi e rocciosi.
- A suo agio su: terreni pieni di radici, rocciosi, tecnici.
- Taglie: MD, LG, XL.
- Peso telaio Turq Series: 2,43 Kg.
- Peso telaio Carbon Series: 2,67 Kg.
- Colore: Storm, Black.

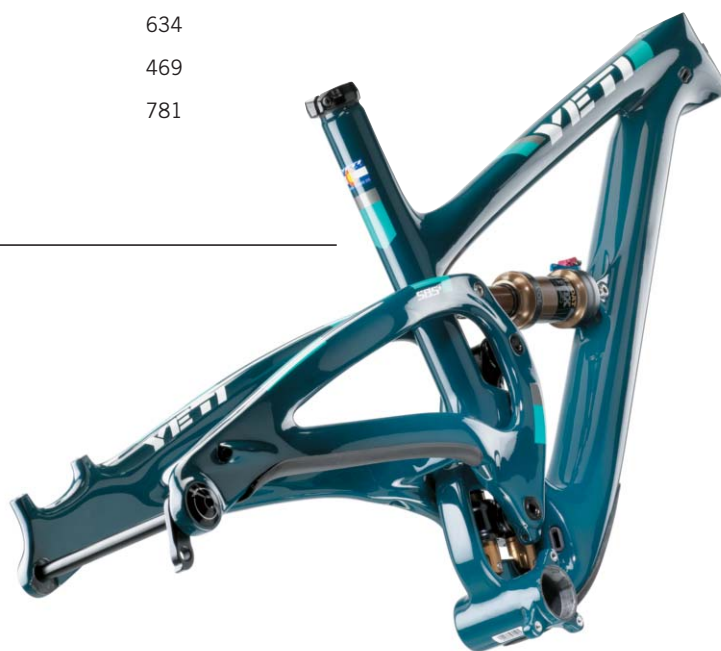

**SB5+ T-Series
SHIMANO XT**
**SB5+ T-Series
SRAM X01 EAGLE**
**SB5+ T-Series
SRAM XX1 EAGLE**

Frame	T-Series	T-Series	T-Series
Fork	Fox Factory 34 150 27+	Fox Factory 34 150 27+	Fox Factory 34 150 27+
Shock	Fox Factory	Fox Factory	Fox Factory
Front Tire	Maxxis Rekon 2.8	Maxxis Rekon 2.8	Maxxis Rekon 2.8
Rear Tire	Maxxis Rekon 2.8	Maxxis Rekon 2.8	Maxxis Rekon 2.8
Rear Rotor	Shimano SMTR66M	Sram Centerline 180	Sram Centerline 180
Front Rotor	Shimano SMTR66M	Sram Centerline 180	Sram Centerline 180
Headset	Cane Creek 40 Inset Taper	Cane Creek 40 Inset Taper	Chris King-
Wheelset	Dt Swiss 350 /XM551 Wheelset 27 6-Bolt	Dt Swiss 350 /XM551 Wheelset 27 6-Bolt	Dt Swiss 350 /XM551 Wheelset 27 6-Bolt
BB	Race Face BB92 30mm	Sram Gxp BB92	Sram Gxp BB92
Tubes	Stans	Stans	Stans
Bar	Yeti 800x35 Turq	Yeti 800x35 Turq	Yeti 800x35 Turq
Stem	Race Face Turbine Basic 50x35mm	Race Face Turbine Basic 50x35mm	Race Face Turbine 50x35mm
Small	Small Parts Kit (4mm)	Small Parts Kit (4mm)	Small Parts Kit (4mm)
Crank	Race Face Turbine	Sram X01 Carbon 52mm	Sram X01 Carbon 52mm
Seat	WTB Custom Saddle	WTB Custom Saddle	Ergon
Front Brake	Shimano XT	Sram Guide RSC	Sram Guide RSC
Rear Brake	Shimano XT	Sram Guide RSC	Sram Guide RSC
Rear Der	Shimano XT	Sram X01 Eagle	Sram XX1 Eagle
Cassette	Shimano XT 11-46	Sram 1275	Sram 1299 Eagle Gold
Chain	Shimano SLX	Sram GX	Sram 1299 Eagle Gold
Shift	Shimano XT	Sram X01 Eagle	Sram XX1 Eagle
Clamps/Adapt	N/A	Sram MMX/Left	Sram MMX/Left
Post	Fox Transfer	Fox Transfer	Fox Transfer
Prezzo telaio	€4.299,00	€4.299,00	€4.299,00
Prezzo bici	€7.499,00	€8.199,00	€10.799,00

**SB5+ C-Series
SHIMANO XT/SLX**
**SB5+ C-Series
SRAM GX EAGLE**

Frame	C-Series	C-Series
Fork	Fox Performance 34 150 27+	Fox Performance 34 150 27+
Shock	Fox Performance	Fox Performance
Front Tire	Maxxis Rekon 2.8	Maxxis Rekon 2.8
Rear Tire	Maxxis Rekon 2.8	Maxxis Rekon 2.8
Rear Rotor	Shimano SMTR66M	Sram Centerline 180
Front Rotor	Shimano SMTR66M	Sram Centerline 180
Headset	Cane Creek 40 Inset Taper	Cane Creek 40 Inset Taper
Wheelset	DT Swiss 370/M542 Wheelset 27 6-Bolt	DT Swiss 370/M542 Wheelset 27 6-Bolt
BB	Race Face BB92 Shim	Sram Gxp BB92
 Tubes	Stans	Stans
Bar	Race Face Evolve Bar 750	Race Face Evolve Bar 750
Stem	Race Face Ride 60	Race Face Ride 60
Small	Small Parts Kit (4mm)	Small Parts Kit (4mm)
Crank	Race Face Affect	Sram GX
Seat	WTB Custom Saddle	WTB Custom Saddle
Front Brake	Shimano SLX	Sram Guide R
Rear Brake	Shimano SLX	Sram Guide R
Rear Der	Shimano XT	Sram X01
Cassette	Shimano SLX KCSM7000146	Sram 1275
Chain	Shimano SLX	Sram GX Eagle
Shift	Shimano SLX	Sram GX Eagle
Clamps/Adapt	N/A	Sram MMX/Left
Post	Fox Transfer	Fox Transfer
Prezzo bici	€5.699,00	€6.199,00



SB5

Con le ruote da 27,5" di diametro, la Yeti SB5 è la trail bike perfetta per chi ama giocare in bici.

Puoi fare di tutto con il giusto talento nella guida, ma anche se non hai tutto il manico che vorresti i 127 mm di escursione della Sb5 e la sua geometria permettono margini elevatissimi.

È la bici perfetta per uscite lunghissime in montagna oppure per le sparate di un'ora a manetta sui tuoi sentieri preferiti.

Con una forcella da 160 mm di corsa è più vicina di quanto pensi alla Sb6 e alle bici da enduro.

Punta lo sguardo lontano e vai...

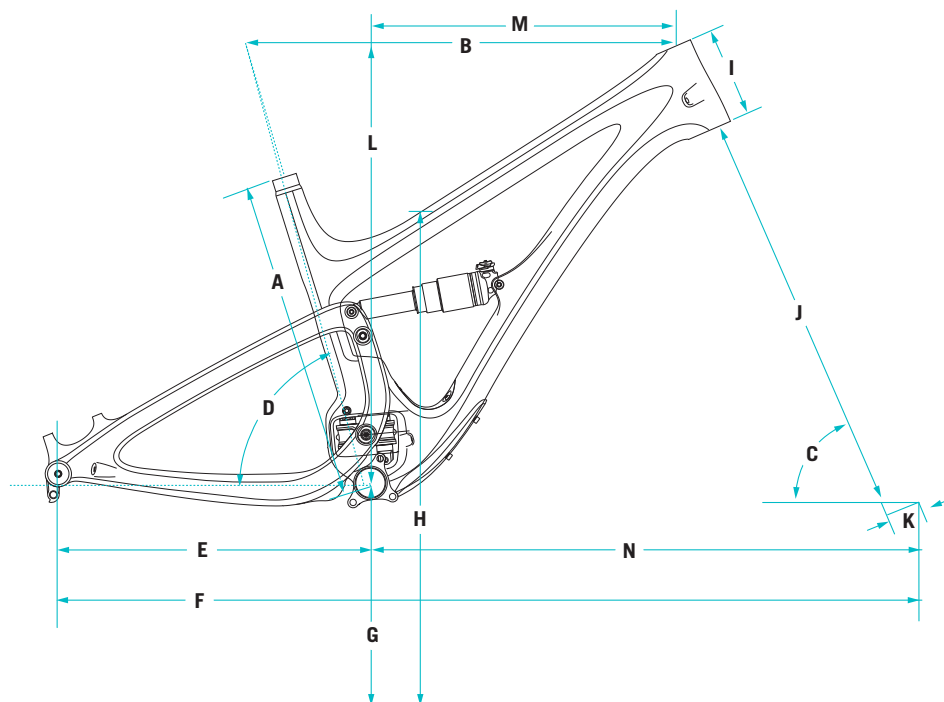

GEOMETRIA

(Forcella da 160 mm. Misure in mm)

	MD	LG	XL
A Seat Tube Length	445	483	521
B Toptube Length	605	630	656
C Headtube Angle °	66.1	66.1	66.1
D Eff. Seat Tube Angle °	73.1	73.1	73.1
E Chainstay Length	437	437	437
F Wheelbase	1172	1199	1226
G Estimated BB Height	341	341	341
H Standover	732	745	757
I Headtube Length	127	144	165
J Axle to Crown	549	549	549
K Offset	44	44	44
L Stack	613	629	648
M Reach	419	439	458
N Front Center	735	762	790



CARATTERISTICHE

- 127 mm di escursione Switch Infinity.
- Ruote da 27,5".
- Battuta Boost.
- Garanzia di 5 anni sul telaio.
- Perfetta per: sentieri tecnici, curve strette.
- A suo agio su: stretto, guidato e veloce.
- Taglie: MD, LG, XL.
- Peso telaio: 2,66 kg Turq Series.
- Colore: Tourquise, Black.

- Disponibile anche versione Beti da donna.





	SB5 T-Series SHIMANO XT	SB5 T-Series SRAM X01 EAGLE	SB5 T-Series SRAM X01 EAGLE LR	SB5 T-Series SRAM XX1 EAGLE
Frame	T-Series	T-Series	T-Series	T-Series
Fork	Fox Factory 34 150 27	Fox Factory 34 150 27	Fox Factory 36 160 27	Fox Factory 34 150 27
Shock	Fox Factory	Fox Factory	Fox Factory Float X	Fox Factory
Front Tire	Maxxis Ardent 2.4 Fold EXO/TR	Maxxis Ardent 2.4 Fold EXO/TR	Maxxis Minion DHF 2.5	Maxxis Ardent 2.4 Fold EXO/TR
Rear Tire	Maxxis Ardent 2.4 Fold EXO/TR	Maxxis Ardent 2.4 Fold EXO/TR	Maxxis Aggressor 2.3	Maxxis Ardent 2.4 Fold EXO/TR
Rear Rotor	Shimano SMTR66M	Sram Centerline 160	Sram Centerline 180	Sram Centerline 160
Front Rotor	Shimano SMRT66S	Sram Centerline 180	Sram Centerline 180	Sram Centerline 180
Headset	Cane Creek 40 Inset Taper	Cane Creek 40 Inset Taper	Cane Creek 40 Inset Taper	Cane Creek 40 Inset Taper
Wheelset	DT Swiss 350 W/XM421	DT Swiss 350 W/XM421	DT Swiss 350 W/XM481	DT Swiss 350/XM551 Wheelset 27 6-bolt
BB	Race Face BB92 30mm	Sram GXP BB92	Sram GXP BB92	Sram GXP BB92
Tubes	Stans	Stans	Stans	Stans
Bar	Yeti 760x35 Turq	Yeti 760x35 Turq	Yeti 800x35 Turq	Yeti 760x35 Turq
Stem	Race Face Turbine Basic 50x35mm	Race Face Turbine Basic 50x35mm	Race Face Turbine Basic 50x35mm	Race Face Turbine 50x35mm
Small	Small Parts Kit (4mm)	Small Parts Kit (4mm)	Small Parts Kit (4mm)	Small Parts Kit (4mm)
Crank	Race Face Turbine	Sram X01 Carbon 52mm	Sram X01 Carbon 52mm	Sram X01 Carbon 52mm
Seat	WTB Custom Saddle	WTB Custom Saddle	WTB Custom Saddle	Ergon
Front Brake	Shimano XT	Sram Guide RSC	Sram Guide RSC	Sram Guide RSC
Rear Brake	Shimano XT	Sram Guide RSC	Sram Guide RSC	Sram Guide RSC
Rear Der	Shimano XT	Sram X01 Eagle	Sram X01 Eagle	Sram XX1
Cassette	Shimano XT 11-46	Sram 1275	Sram 1275	Sram 1299 Eagle Gold
Chain	Shimano SLX	Sram GX	Sram GX	Sram 1299 Eagle Gold
Shift	Shimano XT	Sram X01 Eagle	Sram X01 Eagle	Sram XX1 Eagle
Clamps/Adapt	N/A	Sram MMX/Left	Sram MMX/Left	Sram MMX/Left
Post	Fox Transfer	Fox Transfer	Fox Transfer	Fox Transfer
Prezzo telaio	€4.299,00	€4.299,00	-	€4.299,00
Prezzo bici	€7.499,00	€8.199,00	€8.499,00	€10.799,00



SB5 C-Series
SHIMANO XT/SLX

SB5 C-Series
SRAM GX EAGLE

	SB5 C-Series SHIMANO XT/SLX	SB5 C-Series SRAM GX EAGLE
Frame	C-Series	C-Series
Fork	Fox Performance 34 150 27	Fox Performance 34 150 27
Shock	Fox Performance	Fox Performance
Front Tire	Maxxis Ardent 2.4 Fold EXO/TR	Maxxis Ardent 2.4 Fold EXO/TR
Rear Tire	Maxxis Ardent 2.4 Fold EXO/TR	Maxxis Ardent 2.4 Fold EXO/TR
Rear Rotor	Shimano SMTR66M	Sram Centerline 160
Front Rotor	Shimano SMRT66S	Sram Centerline 180
Headset	Cane Creek 40 Inset Taper	Cane Creek 40 Inset Taper
Wheelset	DT Swiss M1900 Wheelset 27 25mm Shim	DT Swiss M1900 Wheelset 27 25mm Shim
BB	Race Face BB92 Shim	Sram Gxp BB92
Tubes	Stans	Stans
Bar	Race Face Evolve Bar 750	Race Face Evolve Bar 750
Stem	Race Face Ride 60	Race Face Ride 60
Small	Small Parts Kit (4mm)	Small Parts Kit (4mm)
Crank	Race Face Affect	Sram GX
Seat	WTB Custom Saddle	WTB Custom Saddle
Front Brake	Shimano SLX	Sram Guide R
Rear Brake	Shimano SLX	Sram Guide R
Rear Der	Shimano XT	Sram X01
Cassette	Shimano SLX KCSM7000146	Sram 1275
Chain	Shimano SLX	Sram GX Eagle
Shift	Shimano SLX	Sram GX Eagle
Clamps/Adapt	N/A	Sram MMX/Left
Post	Fox Transfer	Fox Transfer
Prezzo bici	€5.699,00	€6.199,00



SB4.5

La Yeti Sb4.5 non appartiene a nessuna categoria, perché ogni categoria le sta stretta.

È una tuttofare camaleontica capace di far trovare a proprio agio anche con una forcella da 140 mm di escursione, quando al posteriore ha solo 114 mm.

Ha la compatibilità con il reggisella telescopico con passaggio interno del cavo (del resto è una Yeti) e con le ruote da 29" e un telaio leggero (2,40 Kg) se la cava molto bene anche in salita.

Quindi, prima di chiederti a quale categoria appartenga questa bici, assicurati di averla provata.

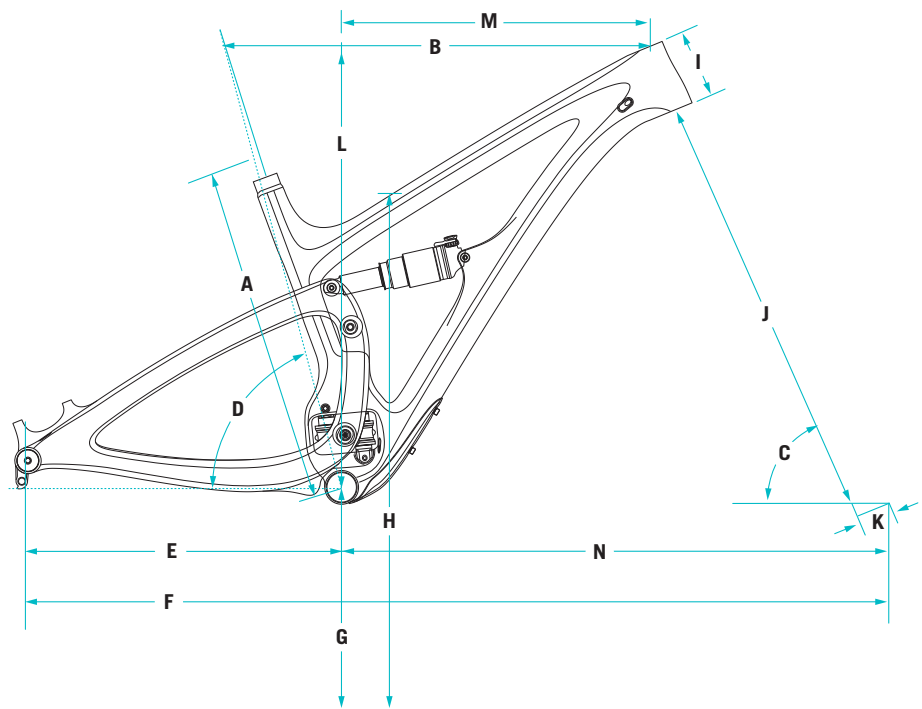

GEOMETRIA

(Forcella da 140 mm. Misure in mm)

	SM	MD	LG	XL
A Seat Tube Length	419	445	483	521
B Toptube Length	579	605	630	655
C Headtube Angle °	67.4	67.4	67.4	67.4
D Eff. Seat Tube Angle °	73.3	73.3	73.3	73.3
E Chainstay Length	437	437	437	437
F Wheelbase	1127	1153	1180	1207
G Estimated BB Height	334	334	334	334
H Standover	751	751	751	751
I Headtube Length	90	95	105	120
J Axle to Crown	547	547	547	547
K Offset	51	51	51	51
L Stack	608	613	622	636
M Reach	397	421	444	465
N Front Center	690	716	743	770

CARATTERISTICHE

- 114 mm di escursione Switch Infinity.
- Ruote da 29".
- Battuta Boost.
- Garanzia di 5 anni sul telaio.
- Perfetta per: sentieri scorrevoli, curve strette.
- A suo agio su: stretto, guidato e lunghe distanze.
- Taglie: SM, MD, LG, XL.
- Peso telaio: 2,40 kg Turq Series, 2,69 kg Carbon Series.
- Colore: Black, Storm.



**SB4.5 T-Series
SHIMANO XT**
**SB4.5 T-Series
SRAM X01 EAGLE**
**SB4.5 T-Series
SRAM XX1 EAGLE**

Frame	T-Series	T-Series	T-Series
Fork	Fox Factory 34 140 29	Fox Factory 34 140 29	Fox Factory 34 140 29
Shock	Fox Factory	Fox Factory	Fox Factory
Front Tire	Maxxis Ardent 2.4 Fold EXO/TR	Maxxis Ardent 2.4 Fold EXO/TR	Maxxis Ardent 2.4 Fold EXO/TR
Rear Tire	Maxxis Ardent 2.25 Fold EXO/TR	Maxxis Ardent 2.25 Fold EXO/TR	Maxxis Ardent 2.25 Fold EXO/TR
Rear Rotor	Shimano SMTR66M	Sram Centerline 160	Sram Centerline 160
Front Rotor	Shimano SMRT66S	Sram Centerline 160	Sram Centerline 160
Headset	Cane Creek 40 Inset Taper	Cane Creek 40 Inset Taper	Chris King
Wheelset	DT Swiss 350 W/XM421	DT Swiss 350 W/XM421	DT Swiss 350 W/XM421
BB	Race Face BB92 30mm	Sram GXP BB92	Sram GXP BB92
Tubes	Stans	Stans	Stans
Bar	Yeti 760X35 Turq	Yeti 760x35 Turq	Yeti 760x35 Turq
Stem	Race Face Turbine Basic 50x35mm	Race Face Turbine Basic 50x35mm	Race Face Turbine Stem 50mm
Small	Small Parts Kit (4mm)	Small Parts Kit (4mm)	Small Parts Kit (4mm)
Crank	Race Face Turbine	Sram X01 Carbon 52mm	Sram X01 Carbon 52mm
Seat	WTB Custom Saddle	WTB Custom Saddle	Ergon
Front Brake	Shimano XT	Sram Guide RSC	Sram Guide RSC
Rear Brake	Shimano XT	Sram Guide RSC	Sram Guide RSC
Rear Der	Shimano XT	Sram X01 Eagle	Sram XX1 Eagle
Cassette	Shimano XT 11-46	Sram 1275	Sram 1299 Eagle Gold
Chain	Shimano SLX	Sram GX	Sram 1299 Eagle Gold
Shift	Shimano XT	Sram X01	Sram XX1 Eagle
Clamps/Adapt	N/A	Sram MMX/Left	Sram MMX/Left
Post	Fox Transfer	Fox Transfer	Fox Transfer
Prezzo telaio	€4.299,00	€4.299,00	€4.299,00
Prezzo bici	€7.499,00	€8.199,00	€9.199,00

**SB5 C-Series
SHIMANO XT/SLX**
**SB5 C-Series
SRAM GX EAGLE**

Frame	C-Series	C-Series
Fork	Fox Performance 34 140 29	Fox Performance 36 160 27
Shock	Fox Performance	Fox Performance
Front Tire	Maxxis Ardent 2.4 Fold Exo/TR	Maxxis Ardent 2.4 Fold Exo/TR
Rear Tire	Maxxis Ardent 2.25 Fold Exo/TR	Maxxis Ardent 2.25 Fold Exo/TR
Rear Rotor	Shimano SMTR66M	Sram Centerline 160
Front Rotor	Shimano SMRT66S	Sram Centerline 160
Headset	Cane Creek 40 Inset Taper	Cane Creek 40 Inset Taper
Wheelset	Dt Swiss M1900 Wheelset 29 6-Bolt Shim	Dt Swiss M1900 Wheelset 29 6-Bolt Shim
BB	Race Face BB92 Shim	Sram Gxp BB92
 Tubes	Stans	Stans
Bar	Race Face Evolve Bar 750	Race Face Evolve Bar 750
Stem	Race Face Ride 60	Race Face Ride 60
Small	Small Parts Kit (4mm)	Small Parts Kit (4mm)
Crank	Race Face Affect 30t	Sram GX
Seat	WTB Custom Saddle	WTB Custom Saddle
Front Brake	Shimano SLX	Sram Guide R
Rear Brake	Shimano SLX	Sram Guide R
Rear Der	Shimano XT	Sram X01
Cassette	Shimano SLX KCSM7000146	Sram 1275
Chain	Shimano SLX	Sram GX Eagle
Shift	Shimano SLX	Sram GX Eagle
Clamps/Adapt	N/A	Sram MMX/Left
Post	Fox Transfer	Fox Transfer
Prezzo bici	€5.699,00	€6.199,00





Se tu oggi provassi a creare un nuovo marchio di bici?

Se tu oggi provassi a creare un nuovo marchio di bici e anche riuscissi a farlo figo, anzi fighissimo, a vendere solo online a prezzi super concorrenziali, a ingaggiare i piloti più bravi, e a farlo diventare un riferimento, presto o tardi ti scontreresti con un fatto: che il tuo marchio non ha una storia. Cioè, magari sarai pure cool, ma alla fine, sotto sotto, scusa

la franchezza, non sei nessuno.

Sei un marchio che oggi va di moda e che vende a prezzi bassi.

Ma ti manca un pezzo cruciale: non hai una storia.

E il non avere una storia presto o tardi ti sbatterà in faccia la verità: il tuo marchio non vale così tanto.

Tutto questo conduce a una riflessione.



A 2 cose devi fare attenzione: non darle subito del tu e aspetta di capire in cosa non è perfetta. Perché nessun grande amico è perfetto.



Cioè l'importanza che la storia (intesa come tradizione, esperienza, longevità, solidità) riveste per i marchi a cui siamo più affezionati e il discorso riguarda non solo l'ambito bici, ma tutti brand che circondano la nostra vita.

Ad alcuni marchi diamo una fiducia istantanea, riconosciamo loro un valore superiore (e accettiamo di pagarli di più), ammettiamo senza problemi di sentirne il fascino e ci professiamo fan senza vergogna. Perché tutto questo?

Possibile che sia tutto merito del marketing?

No, in effetti no, c'è dell'altro.

Molto altro, diverso da marchio a marchio.

Facciamo l'esempio di Yeti.

È un marchio che pur non godendo di una notorietà indiscussa (non è la Bianchi, per capirci), è comunque amato e noto a tutti gli appassionati al punto da essere diventato un'icona.

Un riferimento vero.

Basti pensare che le colorazioni di anno in anno sono quasi sempre le stesse.

Il turchese Yeti è iconico.

Alla domanda:

«Mi piacerebbe avere una Yeti?»

La risposta potrebbe essere la stessa per tutti, a prescindere



dall'età anagrafica, dal portafoglio e da una serie infinita di fattori.

Se sei molto giovane, diciamo sotto i 30 anni, forse non risponderesti subito di sì.

Ci pensi un attimo, pensi a chi le usa in gara, a quale dei tuoi amici ne ha una e poi pensi a come sono fatte.

La sospensione posteriore, i colori, le geometrie e le scelte

diciamo filosofiche, che rendono le Yeti così differenti. Di un altro livello.

E a quel punto inizi a riflettere su chi sia Yeti e da dove venga fuori.

Ed è lì che ti imbatti nella sua storia che è iniziata nel 1985 (probabilmente nemmeno eri nato), ossia un'era geologica fa parlando di ruote grasse.

Diamine, ecco chi è Yeti.



Sì, costa, ma hanno una storia più lunga della tua giovane età.
Sì, sono solo turchese, grigio, giallo, nero, ma sono fighe per questo.

«Beh, sì, quando avrò i soldi me ne prenderò una».

Se sei giovane, diciamo fra i 40 e i 50 (sì, sei ancora giovane...), sai chi è Yeti e chi ha usato quelle bici nel corso degli oltre 30 anni di storia di questo marchio.

Sai che il nome Yeti è un'icona, è evocativo di scenari magnifici e di grandi personaggi, di vittorie e di successi ottenuti a volte fin troppo in sordina.

Insomma, una Mtb Yeti vale tanto, proprio perché ha una storia che pesa e che ne delinea l'identità attuale.

Non ci sono isterismi da fanboy, non ci sono fisse o hashtag particolari, niente di tutto ciò, c'è solo la storia, ossia un susseguirsi di eventi e fatti che hanno segnato la strada fino ai giorni nostri.

E alla domanda di cui sopra, risponderesti, «Cazzo, sì!»

Se il tuo volto e la tua capigliatura (o ciò che ne resta) dicono chiaramente che hai passato i 50, quando pensi a Yeti ti sale un po' di rabbia, nostalgia, adrenalina, gioia ed eccitazione tutte insieme, perché quel marchio ti riporta all'epoca in cui la mountain bike forse nemmeno si chiamava così.

Ma Yeti c'era già.

Non c'era internet, non c'era la fibra di carbonio e per avere le notizie andavi in edicola e, pensa, spendevi dei soldi.

Sì, per saperne di più di quel marchio, di quel mondo, di una qualunque cosa aprivi il portafoglio e compravi le riviste.

Un'era geologica fa.

E se oggi ti chiedessero se ti piacerebbe avere una Yeti risponderesti: «Ne ho già avute un paio, ne riprenderei di sicuro un'altra».

I marchi che contano sono come gli amici di cui ti fidi.

Se ti invitano a uscire o a fare un weekend fuori per provare qualcosa di nuovo tu dici di sì.

Perché ti fidi e sai già che sarà un weekend figo.

Quando sali sopra una Yeti puoi aspettarti qualcosa di molto simile.

Devi sapere che state per diventare amici perché la storia di quel marchio, sotto al tuo fondoschiena e nella presa delle manopole, sembra parlare e spiegarti che cos'è la mountain bike.

Come si guida una mountain bike.

Cosa si può fare con la mountain bike.

Da dove viene la mountain bike.

E a fregartene delle mode e degli isterismi.

Solo a due cose devi fare attenzione, proprio come accade quando hai a che fare con i marchi di spicco: non darle subito del tu e aspetta che ti mostri in cosa non è perfetta. Perché nessun grande amico è perfetto.





ROCKY MOUNTAIN



★ d s b ★

SEMPLICEMENTE BICI



La gamma 2018 Rocky Mountain arriva direttamente al cuore. Il sacro rispetto che questo marchio ha per la propria identità lo ha portato a raggiungere livelli di appeal e qualità che pochi altri marchi possono vantare. L'ultima dimostrazione è la Altitude Powerplay, ossia la prima e-Bike del marchio canadese, costruita come piace a Rocky Mountain, senza scorciatoie. Con l'arrivo della versione rinnovata della Slayer, Rocky Mountain ha cambiato passo, tornando a guidare in fatto di caratteristiche tecniche, le bici da enduro, le bici per una guida aggressiva e i mezzi che in generale evocano il North Shore. Insomma, le Rocky Mountain 2018 sono da guardare con molta attenzione...

ALTITUDE POWERPLAY

Questa bici alza l'asticella in campo e-Bike per il modo in cui stata concepita e realizzata.

Una sfida per Rocky Mountain perchè con la Altitude Powerplay ha dimostrato di credere nelle e-bike al punto da sviluppare un modello di grande unicità.

Telaio in fibra di carbonio

Smoothwall, motore sviluppato in casa, batteria maggiorata da 632 Wh, geometria copiata alla Altitude con tutti i benefici che ne conseguono nella guida, sistema Ride9 e personalizzazione dell'erogazione del motore. Ecco perchè l'asticella ora è più in alto.

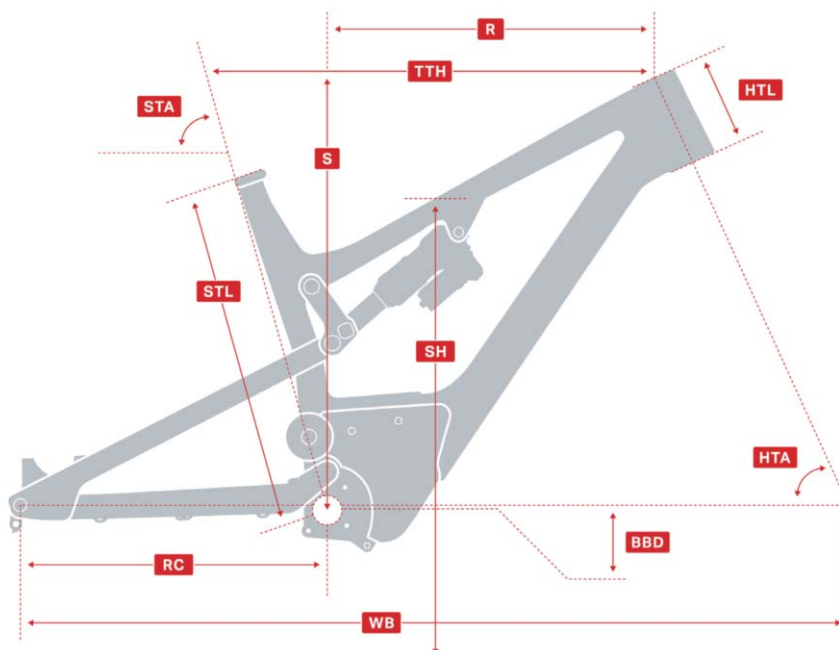

GEOMETRIA

	SM			MD			LG			XL		
	<i>Slack</i>	<i>Neutral</i>	<i>Steep</i>	<i>Slack</i>	<i>Neutral</i>	<i>Steep</i>	<i>Slack</i>	<i>Neutral</i>	<i>Steep</i>	<i>Slack</i>	<i>Neutral</i>	<i>Steep</i>
HTA Head Tube Angle (deg)	64.5°	65°	65.6°	65°	65.6°	66.1°	65°	65.6°	66.1°	65.1°	65.6°	66.1°
STA Seat Tube Angle (deg)	74°	74.5°	75.1°	74°	74.6°	75.1°	74°	74.6°	75.1°	74.1°	74.6°	75.1°
STL Seat Tube Length (mm)	419	419	419	457	457	457	483	483	483	521	521	521
TTH Top Tube Horizontal (mm)	578	576	575	603	601	600	628	626	625	658	656	655
HTL Head Tube Length (mm)	100	100	100	120	120	120	130	130	130	145	145	145
RC Rear Centre (mm)	426	425	423	426	425	423	426	425	423	426	425	423
BBD Bottom Bracket Drop (mm)	14	7	1	14	7	1	14	7	1	14	7	1
SH Standover Height (mm)	810	813	816	816	818	821	814	816	819	813	816	819
WB Wheelbase (mm)	1157	1156	1155	1180	1179	1177	1206	1205	1204	1239	1238	1236
R Reach (mm)	411	416	422	430	435	441	452	464	464	479	484	490
S Stack (mm)	583	579	575	604	600	596	614	610	605	628	623	619

CARATTERISTICHE

- travel posteriore di 150 mm
- travel anteriore di 160 mm
- Ruote da 27,5" Wide Trail
- Triangolo anteriore in fibra di carbonio Smoothwall
- Carro in lega leggera (sulle versioni Carbon 70 e Carbon 50)
- Batteria da 632 Wh (di serie su Carbon 90 e Carbon 70)
- 4 taglie: S, M, L e XL
- Colore: Tank Girl-Acid Rain (Altitude Powerplay 90 Carbon)
Tank Girl-Acid Rain, Back in Black-Acid Rain (Altitude Powerplay 70 Carbon)
Back in Black-Acid Rain (Altitude Powerplay 50 Carbon).





**ALTITUDE POWERPLAY
90 CARBON**

**ALTITUDE POWERPLAY
70 CARBON**

**ALTITUDE POWERPLAY
50 CARBON**

Frame	SMOOTHWALL™ carbon frame. Full Sealed Cartridge Bearings. Press Fit BB. Internal Cable Routing. ISCG05 Tabs. RIDE-9™ Adjustable Geometry + Suspension Rate. 250 W / 48V Powerplay Drive. Li-Ion 632 Watt/Hr.	SMOOTHWALL™ carbon front triangle, FORM™ alloy rear triangle. Full Sealed Cartridge Bearings. Press Fit BB. Internal Cable Routing. ISCG05 Tabs. RIDE-9™ Adjustable Geometry + Suspension Rate. 250 W / 48V Powerplay Drive. Li-Ion 632 Watt/Hr.	SMOOTHWALL™ Carbon. Full Sealed Cartridge Bearings. Press Fit BB. Internal Cable Routing. ISCG05 Tabs. RIDE-9™ Adjustable Geometry + Suspension Rate. 250 W / 48V Powerplay Drive. Li-Ion 500 Watt/Hr.
Fork	Fox 36 Float EVOL FIT4 Factory 160mm	Fox 36 Float EVOL Grip Performance 160mm	RockShox Yari RC 160mm
Shock	Fox Float DPS EVOL Factory 150mm	Fox Float DPS EVOL Performance Elite 150mm	RockShox Deluxe RT 150mm
Headset	FSA Orbit NO.57 Steerer Stop	FSA Orbit NO.57 Steerer Stop	FSA Orbit NO.57 Steerer Stop
Stem	Rocky Mountain 35 CNC DH	Rocky Mountain 35 AM	Rocky Mountain 35 AM
Handlebar	Race Face Next R 780mm	Race Face Chester 780mm	Race Face Chester 780mm
Grips	Rocky Mountain Lock On XC	Rocky Mountain Lock On Light	Rocky Mountain Lock On Light
Brakes	SRAM Guide RE. Sram Centerline 200mm	SRAM Guide RE. Sram Centerline 200mm.	SRAM Guide RE. Sram Centerline 200mm.
Brake Levers	SRAM Guide RE	SRAM Guide RE	SRAM Guide RE
Shifters	SRAM EX1	SRAM EX1	SRAM EX1
Rear Derailleur	SRAM EX1	SRAM EX1	SRAM EX1
Cranks & Chainrings	Race Face Next Cinch 34T	Race Face Next Cinch 34T	Race Face Next Cinch 34T
Bottom Bracket	Race Face BB92	Race Face BB92	Race Face BB92
Cassette	SRAM XG-899 11-48T	SRAM XG-899 11-48T	SRAM XG-899 11-48T
Chain	SRAM EX1	SRAM EX1	SRAM EX1
Front Hub	Rocky Mountain Sealed Boost 15mm	Rocky Mountain Sealed Boost 15mm	Rocky Mountain Sealed Boost 15mm
Rear Hub	DT Swiss 350 Boost 148mm	DT Swiss 350 Boost 148mm	Sram MTH 746 Boost 148mm
Spokes	WTB 2.0-1.8	WTB 2.0-1.8	WTB 2.0-1.8
Rims	Rocky Mountain 30AM Carbon Tubeless Ready - Tape / Valves Incl.	Sun Dürac 40. Tubeless Ready Tape / Valves Incl.	Sun Dürac 40. Tubeless Ready Tape / Valves Incl.
Tires	Maxxis Minion DHF WT Maxx Terra 3C Tubeless Ready 27.5 x 2.5	Maxxis Minion DHF WT EXO Tubeless Ready 27.5 x 2.5	Maxxis Minion DHF WT EXO Tubeless Ready 27.5 x 2.5
Seatpost	Fox Transfer Performance Elite 30.9mm 125mm Drop (S), 150mm Drop (M-XL)	Fox Transfer Performance Elite 30.9mm 125mm Drop (S), 150mm Drop (M-XL)	Race Face Aeffect Dropper 30.9mm. S: 125mm Drop / M - XL: 150mm Drop.
Saddle	WTB Silverado Race	WTB Silverado Race	WTB Volt Race
Weight	22.3kg	22.3kg	22.3kg
Prezzo bici	€9.999,00	€7.399,00	€6.399,00

ELEMENT 29

La Rocky Mountain Element 29 è una delle poche (e forse delle ultime) full con vocazione Xc a permettere una simile ampiezza di personalizzazioni della geometria e del comportamento grazie al sistema Ride9.

Lo eredita dai modelli più "cattivi" e lo interpreta in chiave Xc in modo perfetto. La Rocky Mountain Element 29 è la bici con cui partecipare alle gare Xc, alle marathon e anche divertirsi nella guida sui single track grazie ad un angolo di sterzo da 68,6-69,8° e a una costruzione sapiente del telaio in fibra di carbonio Smoothwall.

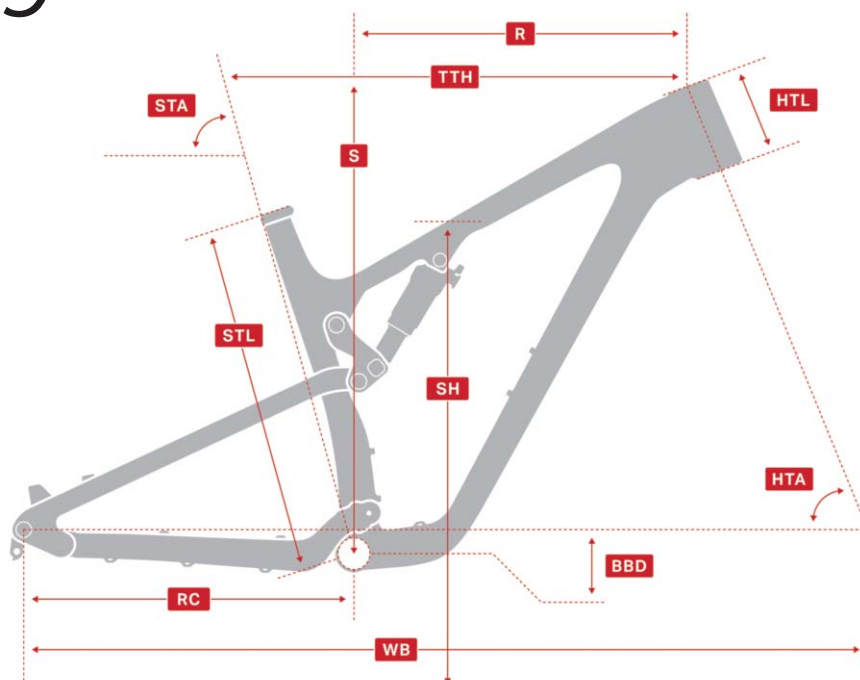

GEOMETRIA

	SM			MD			LG			XL			XXL		
	Slack	Neutral	Steep	Slack	Neutral	Steep	Slack	Neutral	Steep	Slack	Neutral	Steep	Slack	Neutral	Steep
HTA Head Tube Angle (deg)	68.6°	69.2°	69.8°	68.7°	69.2°	69.8°	68.7°	69.2°	69.8°	68.7°	69.2°	69.8°	68.7°	69.2°	69.8°
STA Seat Tube Angle (deg)	74.1°	74.7°	75.3°	74.2°	74.7°	75.3°	74.2°	74.7°	75.3°	74.2°	74.7°	75.3°	74.2°	74.7°	75.3°
STL Seat Tube Length (mm)	394	394	394	432	432	432	470	470	470	508	508	508	546	546	546
TTH Top Tube Horizontal (mm)	567	566	564	592	591	589	617	616	614	648	646	644	668	666	664
HTL Head Tube Length (mm)	93	93	93	103	103	103	118	118	118	128	128	128	143	143	143
RC Rear Centre (mm)	439	438	437	439	438	437	439	438	437	439	438	437	439	438	437
BBD Bottom Bracket Drop (mm)	44	38	31	44	38	31	45	38	31	45	38	31	45	38	31
SH Standover Height (mm)	821	823	825	819	821	823	820	822	824	817	820	822	819	821	824
WB Wheelbase (mm)	1109	38	1108	1135	38	1134	1161	38	1160	1192	38	1191	1214	38	1213
R Reach (mm)	395	401	407	418	424	430	439	445	451	467	472	478	483	489	495
S Stack (mm)	606	602	598	615	611	607	630	625	621	639	635	630	653	649	644

CARATTERISTICHE

- Travel posteriore di 100 mm.
- Travel anteriore di 100 o 120 mm.
- Ruote da 29".
- Triangolo anteriore in fibra di carbonio Smoothwall.
- Carro in lega leggera Form (solo modello Carbon 50).
- Sistema Ride9 per regolazione geometria.
- Trasmissione Sram Eagle 12v su tutti gli allestimenti.
- 5 taglie: S, M, L, XL e XXL.
- Colore: Back in Black-Flaming Lips-Whitesnake (Element 29 Carbon 99)
Acid Rain-Night Train, Smoke on the Water-Back in Black-Whitesnake (Element 29 Carbon 70 / 50 / 30).



**ELEMENT 29
CARBON 99**
**ELEMENT 29
CARBON 70 XCO EDITION**
**ELEMENT 29
CARBON 50**
**ELEMENT 29
CARBON 30**

	ELEMENT 29 CARBON 99	ELEMENT 29 CARBON 70 XCO EDITION	ELEMENT 29 CARBON 50	ELEMENT 29 CARBON 30
Frame	SMOOTHWALL™ Carbon RIDE-9™ Adjustable Geometry	SMOOTHWALL™ Carbon RIDE-9™ Adjustable Geometry	SMOOTHWALL™ Carbon RIDE-9™ Adjustable Geometry	SMOOTHWALL™ Carbon RIDE-9™ Adjustable Geometry
Shock	Fox Float DPS Remote Factory 100mm	Fox Float DPS Remote Performance Elite 100mm	Fox Float DPS Remote Performance Elite	RockShox Monarch RL
Fork	Fox 34 Float Factory 120mm	Fox 32 Step Cast Performance 100mm	Fox 34 Float Performance 120mm	RockShox Reba RL 120mm
R. Derailleur	Sram XX1 Eagle	Sram X01 Eagle	Sram GX Eagle	Shimano SLX
F. Derailleur	-	-	-	-
Chainguide	-	-	-	-
Shifters	Sram XX1 Eagle	Sram GX Eagle	Sram GX Eagle	Shimano SLX
Brakes	Sram Level Ultimate	Sram Level TL	Shimano SLX	Shimano MT500
Rotors	-	-	Shimano RT66	Shimano RT54
Crankset	Sram XX1 Eagle 32T	Sram X1 Carbon Eagle 32T	Sram Stylo 6k Eagle 32T	FSA Comet Modular 38/28T
Cassette	Sram XG-1299 10-50T	Sram XG-1275 10-50T	Sram XG-1275 10-50T	Shimano SLX 11-40T
Chain	Sram XX1 Eagle	Sram GX Eagle	Sram GX Eagle	KMC X11-1
Handlebar	Race Face Next 760mm	Race Face Turbine 760mm	Rocky Mountain AM 760mm	Rocky Mountain AM 760mm
Stem	Rocky Mountain 35 CNC	Rocky Mountain 35 AM	Rocky Mountain AM	Rocky Mountain AM
Grips	Rocky Mountain Lock On XC	Rocky Mountain Lock On XC	Rocky Mountain Lock On XC	Rocky Mountain Lock On Light
Headset	FSA Orbit NO.57E	FSA Orbit NO.57E Extend-o-matic	FSA Orbit NO.57E	FSA Orbit NO.57E
Seatpost	Fox Transfer Factory 30.9mm	Rocky Mountain Carbon SL 30.9mm	Rocky Mountain SL 30.9mm	Rocky Mountain SL 30.9mm
Saddle	WTB Silverado Titanium	WTB Silverado Race	WTB Silverado Race	WTB Volt Race
Front Tire	Maxxis Forekaster 3C Maxx Speed Tubeless Ready 29 x 2.35	Maxxis Ikon Maxx Speed 3C Tubeless Ready 29 x 2.2	Maxxis Forekaster EXO Tubeless Ready 29 x 2.35	Maxxis Forekaster EXO Tubeless Ready 29 x 2.35
Rear Tire	Maxxis Ikon Maxx Speed 3C Tubeless Ready 29 x 2.2	Maxxis Ikon Maxx Speed 3C Tubeless Ready 29 x 2.2	Maxxis Ikon Maxx Speed 3C Tubeless Ready 29 x 2.2	Maxxis Ikon Folding 29 x 2.2
Tubes/Sealant	-	-	-	-
Front Hub	Rocky Mountain Sealed Boost 15mm	Rocky Mountain Sealed Boost 15mm	Rocky Mountain Sealed Boost 15mm	Shimano M618 Boost 15mm
Rear Hub	DT Swiss 350 Boost 148mm	DT Swiss 370 Boost 148mm	DT Swiss 370 Boost 148mm	Shimano M618 Boost 148mm
Rim	Rocky Mountain 24XC Carbon Tubeless Ready	Stans Crest MK3 - Tubeless Ready - Tape / Valves incl.	Sun Helix TR25 SL	WTB SX19
Spokes	WTB 1.8-1.6	WTB 1.8-1.6	WTB 1.8-1.6	WTB 2.0
Prezzo telaio	€3.699,00	-	-	-
Prezzo bici	€9.999,00	€5.799,00	€4.499,00	€3.999,00

THUNDERBOLT 27,5

Aggiungi un po' di vitamine e un po' di pepe alla Element 29 e ottieni la Thunderbolt, ossia una trail bike con 120 mm di escursione sulla ruota posteriore che permette una guida ancora più disinvolta senza perdere in efficienza.

È il ponte di collegamento fra l'Xc e il trail riding più impegnativo.

Il telaio in lega leggera Form e il sistema Ride9 permettono al biker di sentirsi a proprio agio e le ruote da 27,5" conferiscono un'agilità enorme.

5 le taglie disponibili e un angolo di sterzo che, volendo, arriva fino a 66,6°...

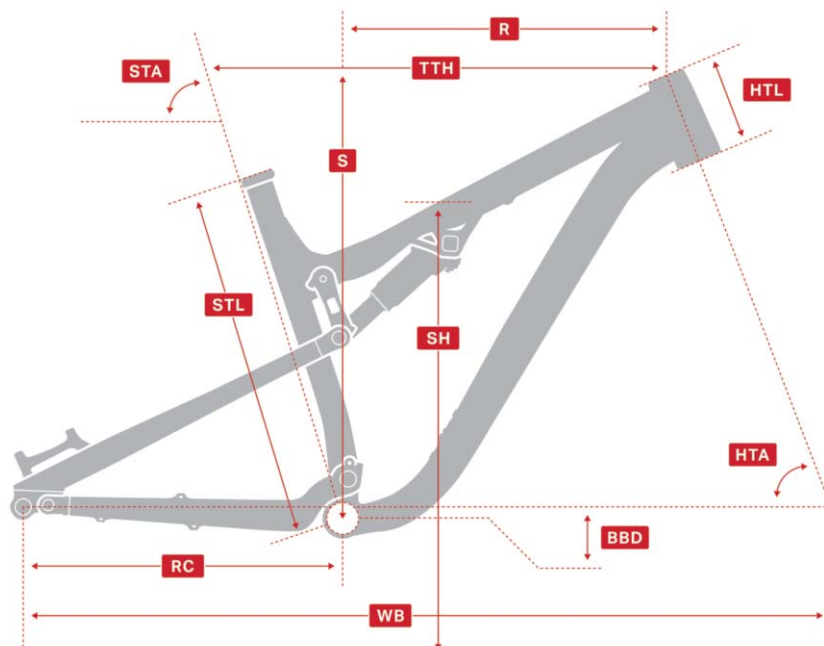

GEOMETRIA

	XS			SM			MD			LG			XL		
	Slack	Neutral	Steep	Slack	Neutral	Steep	Slack	Neutral	Steep	Slack	Neutral	Steep	Slack	Neutral	Steep
HTA Head Tube Angle (deg)	67.2°	68°	68.8°	67.2°	68°	68.8°	67.2°	68°	68.8°	67.2°	68°	68.8°	67.2°	68°	68.8°
STA Seat Tube Angle (deg)	73.7°	74.3°	75.3°	73.7°	74.3°	75.3°	73.7°	74.3°	75.3°	73.7°	74.3°	75.3°	73.7°	74.3°	75.3°
STL Seat Tube Length (mm)	381	381	381	419	419	419	457	457	457	483	483	483	521	521	521
TTH Top Tube Horizontal (mm)	540	540	540	565	565	565	590	590	590	615	615	615	645	645	645
HTL Head Tube Length (mm)	100	100	100	110	110	110	120	120	120	130	130	130	145	145	145
RC Rear Centre (mm)	422	422	422	422	422	422	422	422	422	422	422	422	422	422	422
BBD Bottom Bracket Drop (mm)	25.2	10	4.7	25.2	10	4.7	25.2	10	4.7	25.2	10	4.7	25.2	10	4.7
SH Standover Height (mm)	715	715	715	715	715	715	715	715	715	715	715	715	715	715	715
WB Wheelbase (mm)	1072	1072	1072	1098	1098	1098	1124	1124	1124	1150	1150	1150	1181	1181	1181
R Reach (mm)	376	385	393	398	407	415	420	429	437	443	452	460	469	478	486
S Stack (mm)	552	548	544	561	557	553	570	566	562	580	576	572	594	590	586

CARATTERISTICHE

- Travel posteriore di 120 mm.
- Travel anteriore di 130 mm.
- Ruote da 27,5".
- Telaio in lega leggera Form.
- Sistema Ride9 per regolazione geometria.
- 5 taglie: XS, S, M, L, XL.
- Colore: Tank Girl-Back in Black-Billy Ocean, Back in Black-Flaming Lips (Thunderbolt Alloy 50), Tank Girl-Back in Black-Billy Ocean (Thunderbolt Alloy 30), Back in Black-Flaming Lips (Thunderbolt Alloy 10).





THUNDERBOLT 27.5 Alloy 50

THUNDERBOLT 27.5 Alloy 30

THUNDERBOLT 27.5 Alloy 10

Frame	FORM™ Alloy. BC2™ / ABC™ Pivots RIDE-9™ Adjustable Geometry	FORM™ Alloy. BC2™ / ABC™ Pivots RIDE-9™ Adjustable Geometry	FORM™ Alloy. BC2™ / ABC™ Pivots RIDE-9™ Adjustable Geometry
Shock	Fox Float DPS EVOL Performance	RockShox Monarch RT	RockShox Monarch RT
Fork	Fox 34 Float Performance 130mm	RockShox Recon Gold Air 130mm	RockShox Recon Silver Air 120mm
R. Derailleur	Sram GX	Sram NX	Shimano Deore
F. Derailleur	-	-	Shimano Deore
Chainguide	-	-	-
Shifters	Sram GX	Sram NX	Shimano Deore
Brakes	Sram Level T	Sram Level	Shimano M315
Rotors	Sram Centerline 180mm	Sram Centerline 180 / 160mm	Shimano RT30 160mm
Crankset	Race Face Aeffect Cinch 32T Steel	Race Face Aeffect Cinch 32T Steel	FSA Gamma Drive 36/22T
Cassette	Sram PG-1130 11-42T	Sram PG-1130 11-42T	Shimano HG-50 11-36T
Chain	Sram PC-1110	Sram PC-1110	Shimano HG-54
Handlebar	Rocky Mountain AM 760mm	Rocky Mountain AM 760mm	Rocky Mountain AM 760mm
Stem	Rocky Mountain AM	Rocky Mountain AM	Rocky Mountain AM
Grips	Rocky Mountain Lock On Light	Rocky Mountain Lock On Light	Rocky Mountain Lock On Light
Headset	FSA Orbit NO.57E	FSA Orbit NO.57E	FSA Orbit NO.57E
Seatpost	Race Face Aeffect Dropper 30.9mm	Rocky Mountain SL 30.9mm	Race Face Aeffect Dropper 30.9mm
Saddle	WTB Volt Race	WTB Volt Race	WTB Volt Race
Front Tire	Maxxis Minion DHR II Folding 27.5 x 2.3	Maxxis Minion DHR II Folding 27.5 x 2.3	Maxxis Ardent 27.5 x 2.25
Rear Tire	Maxxis Crossmark II 27.5 x 2.25	Maxxis Crossmark II 27.5 x 2.25	Maxxis Ardent 27.5 x 2.25
Tubes/Sealant	-	-	-
Front Hub	Rocky Mountain Sealed Boost 15mm	Rocky Mountain Sealed Boost 15mm	Shimano TX505
Rear Hub	Sram MTH 746 142mm	Sram MTH 746 142mm	Shimano TX505
Rim	Sun Helix TR25 SL	WTB SX19	WTB SX19
Spokes	WTB 2.0-1.8	WTB 2.0	WTB 2.0
Prezzo bici	€3.699,00	€3.099,00	€2.599,00

INSTINCT 29

Se è vero che le trail bike 29er sono le più interessanti, divertenti e versatili allora non fatevi mancare un giro sulla Rocky Mountain Instinct 29.

L'obiettivo è semplice: facilitare la vita a chi guida e pedala grazie a un tubo superiore la cui lunghezza è quella tipicamente Rocky Mountain, a un carro di 43,5 cm e al sistema Ride 9.

Se poi volete qualcosa di veramente tosto allora date uno sguardo alla versione Bc Edition con forcella Fox 36 Float da 160 mm ed escursione posteriore da 155 mm.

A quel punto tenetevi forte...

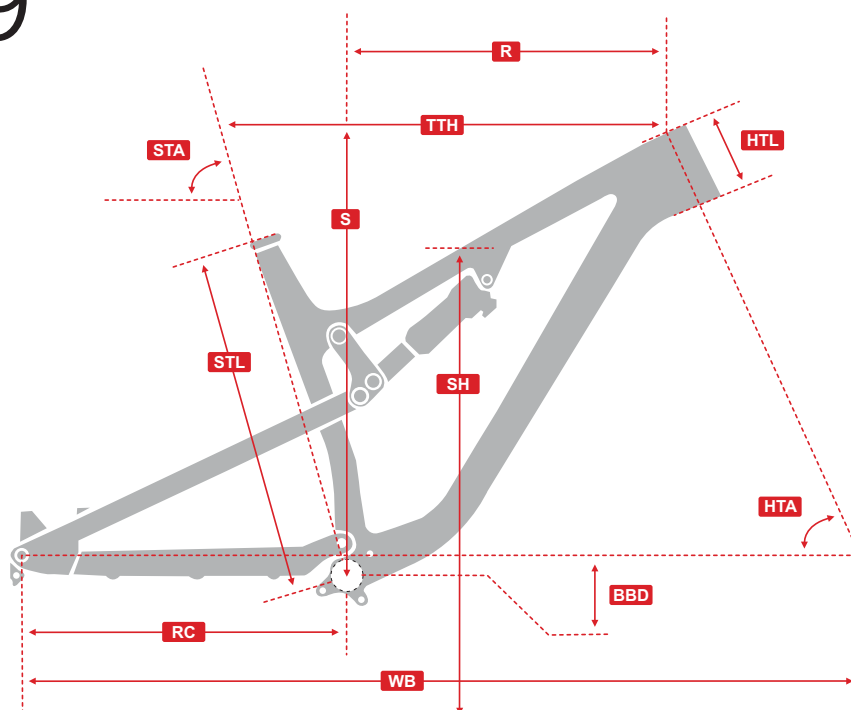

GEOMETRIA

	S	M	L	XL
TTH Top Tube Horizontal (mm)	577	602	627	657
HTA Head Tube Angle (deg)	65.9	65.9	65.9	65.9
HTL Head Tube Length (mm)	95	100	110	120
STA Seat Tube Angle (deg)	74.4	74.4	74.4	74.4
STL Seat Tube Length (mm)	392	432	470	508
RC Rear Centre (mm)	435	435	435	435
BBD Bottom Bracket Drop (mm)	19	19	19	19
R Reach (mm)	407	431	454	481
S Stack (mm)SH	607	612	621	630
SH Standover Height (mm)	828	828	828	828
WB Wheelbase (mm)	1161	1187	1213	1245

CARATTERISTICHE

- Travel posteriore di 140 mm (o 160 mm per la BC Edition).
- Travel anteriore di 140 mm (o 155 mm per la BC Edition).
- Ruote da 29" (compatibile 650b Plus).
- Telaio in fibra di carbonio Smoothwall o lega leggera Form.
- Carro in lega leggera Form (solo Carbon 50, Carbon 30 e Alloy 50).
- Sistema Ride9 per regolazione geometria (tranne Bc Edition).
- 4 taglie: S, M, L, XL.
- Colore: Tank Girl-Fox Racing Orange, Billy Ocean-Back in Black Tank Girl-Back in Black (Instinct 29 Alloy 50).





	INSTINCT 29 CARBON 90 BC EDITION	INSTINCT 29 CARBON 70	INSTINCT 29 CARBON 50	INSTINCT 29 CARBON 30
Frame	SMOOTHWALL™ Carbon	SMOOTHWALL™ Carbon RIDE-9™ Adjustable Geometry	SMOOTHWALL™ Carbon RIDE-9™ Adjustable Geometry	SMOOTHWALL™ Carbon RIDE-9™ Adjustable Geometry
Shock	Fox Float DPX2 Performance Elite 155mm	Fox Float DPS EVOL Performance Elite 140mm	Fox Float DPS EVOL Performance 140mm	RockShox Deluxe Debonair RT 140mm
Fork	Fox 36 Float EVOL FIT4 Performance Elite 160mm	Fox 34 Float Performance Elite 140mm	Fox 34 Float Performance 140mm	RockShox Reba RL 140mm
R. Derailleur	Sram GX Eagle	Sram GX Eagle	Sram GX Eagle	Sram NX
F. Derailleur	Rocky Mountain Spirit Guide	Rocky Mountain Spirit Guide	Rocky Mountain Spirit Guide	Rocky Mountain Spirit Guide
Chainguide	-	-	-	-
Shifters	Sram GX Eagle	Sram GX Eagle	Sram GX Eagle	Sram NX
Brakes	Sram Code R	Sram Guide R	Sram Level TL	Sram Level
Rotors	-	-	-	-
Crankset	Sram Stylo 7k Eagle 32T	Sram Stylo 7k Eagle 32T	Sram Stylo 6k Eagle 32T	Race Face Aeffect Cinch 30T Steel
Cassette	Sram XG-1275 10-50T	Sram XG-1275 10-50T	Sram XG-1275 10-50T	Sram PG-1130 11-42T
Chain	Sram GX Eagle	Sram GX Eagle	Sram GX Eagle	Sram PC-1110
Handlebar	Race Face Turbine R 780mm	Race Face Turbine R 780mm	Rocky Mountain AM 760mm	Rocky Mountain AM 760mm
Stem	Rocky Mountain 35 CNC DH	Rocky Mountain 35 AM	Rocky Mountain AM	Rocky Mountain AM
Grips	Rocky Mountain Lock On XC	Rocky Mountain Lock On XC	Rocky Mountain Lock On Light	Rocky Mountain Lock On Light
Headset	FSA Orbit NO.57E Extend-o-matic	FSA Orbit NO.57E Extend-o-matic	FSA Orbit NO.57E Extend-o-matic	FSA Orbit NO.57E Extend-o-matic
Seatpost	Fox Transfer Performance Elite 30.9mm	Fox Transfer Performance Elite 30.9mm	Race Face Aeffect Dropper 30.9mm	Race Face Aeffect Dropper 30.9mm
Saddle	WTB Silverado Race	WTB Silverado Race	WTB Volt Race	WTB Volt
Front Tire	Maxxis 29 DHF 2.5 EXO Maxx Terra 3C TR	Maxxis Minion DHR II EXO Tubeless Ready 29 x 2.3	Maxxis Minion DHR II EXO Tubeless Ready 29 x 2.3	Maxxis Minion DHR II EXO Tubeless Ready 29 x 2.3
Rear Tire	Maxxis 29 DHRII 2.4 WT EXO Maxx Terra 3C TR	Maxxis Forekaster EXO Tubeless Ready 29 x 2.35	Maxxis Forekaster EXO Tubeless Ready 29 x 2.35	Maxxis Forekaster EXO Tubeless Ready 29 x 2.35
Tubes/Sealant	-	-	-	-
Front Hub	Rocky Mountain Sealed Boost 15mm	Rocky Mountain Sealed Boost 15mm	Rocky Mountain Sealed Boost 15mm	Rocky Mountain Sealed Boost 15mm
Rear Hub	DT Swiss 370 Boost 148mm	DT Swiss 370 Boost 148mm	DT Swiss 370 Boost 148mm	Sram MTH 746 Boost 148mm
Rim	Stans Flow MK3 Tubeless Ready Tape / Valves incl.	Stans Arch MK3 Tubeless Ready Tape / Valves incl.	Sun Duroc 30 Tubeless Compatible - Tape / Valves / Sealant not incl.	Sun Helix TR27 SL Tubeless Compatible Tape / Valves / Sealant not incl.
Spokes	WTB 1.8-1.6	WTB 1.8-1.6	WTB 2.0-1.8	WTB 2.0
Prezzo bici	€6.799,00	€6.199,00	€4.899,00	€4.199,00



INSTINCT 29 Alloy 50

Frame	FORM™ Alloy RIDE-9™ Adjustable Geometry
Shock	Fox Float DPS EVOL Performance 140mm
Fork	Fox 34 Float Performance 140mm
R. Derailleur	Sram GX
F. Derailleur	Rocky Mountain Spirit Guide
Chainguide	-
Shifters	Sram GX
Brakes	Sram Level T
Rotors	-
Crankset	Race Face Aeffect Cinch 30T Steel
Cassette	Sram PG-1130 11-42T
Chain	Sram PC-1110
Handlebar	Rocky Mountain AM 760mm
Stem	Rocky Mountain AM
Grips	Rocky Mountain Lock On Light
Headset	FSA Orbit NO.57E Extend-o-matic
Seatpost	Race Face Aeffect Dropper 30.9mm
Saddle	WTB Volt Race
Front Tire	Maxxis Minion DHR II EXO Tubeless Ready 29 x 2.3
Rear Tire	Maxxis Forekaster EXO Tubeless Ready 29 x 2.35
Tubes/Sealant	-
Front Hub	Rocky Mountain Sealed Boost 15mm
Rear Hub	Sram MTH 746 Boost 148mm
Rim	Sun Duroc 30 Tubeless Compatible - Tape / Valves / Sealant not incl.
Spokes	WTB 2.0-1.8
Prezzo bici	€3.599,00



PIPELINE 27,5 PLUS

Se vi piace la Rocky Mountain Instinct ma volete qualcosa di ancora più facile da guidare, eccovi servita la Pipeline con ruote 650b Plus con una sezione di 2,8". Il telaio è in fibra di carbonio Smoothwall (solo la Carbon 50 ha il carro in lega leggera Form) e il travel è di 140 mm, sia sulla ruota anteriore che sulla posteriore. La Pipeline è pensata per essere guidata alla velocità del pensiero e anche qualcosa di più perchè le gomme Plus con la sospensione SmoothLink di Rocky Mountain permettono di guardare lontano, molto più lontano...

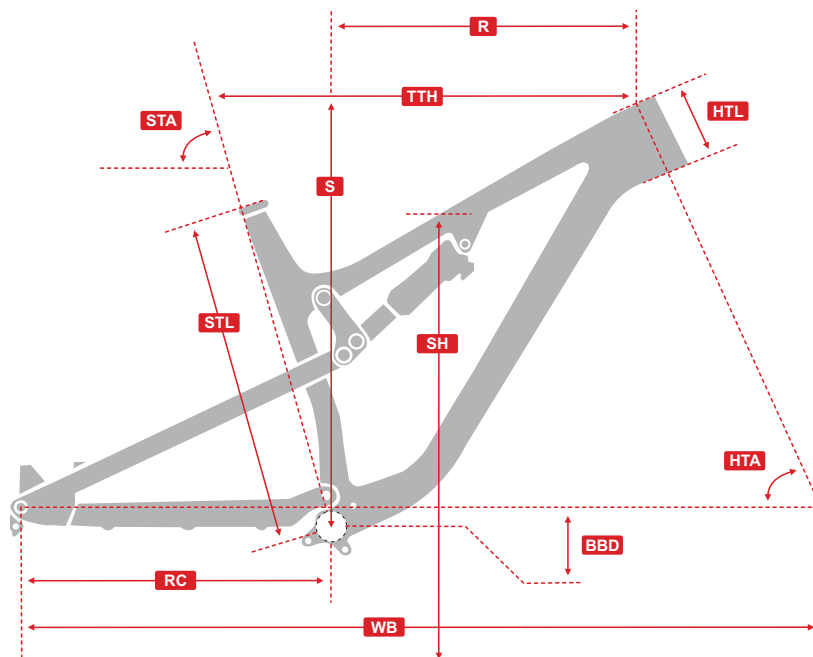

GEOMETRIA

	S	M	L	XL
TTH Top Tube Horizontal (mm)	578	603	628	658
HTA Head Tube Angle (deg)	65.5	65.6	65.6	65.6
HTL Head Tube Length (mm)	95	100	110	120
STA Seat Tube Angle (deg)	74	74.1	74.1	74.1
STL Seat Tube Length (mm)	392	432	470	508
RC Rear Centre (mm)	436	436	436	436
BBD Bottom Bracket Drop (mm)	33	33	33	33
R Reach (mm)	403	427	450	477
S Stack (mm)SH	610	615	624	633
SH Standover Height (mm)	806	806	806	806
WB Wheelbase (mm)	1158	1183	1210	1242

CARATTERISTICHE

- Travel posteriore di 140 mm.
- Travel anteriore di 140 mm.
- Ruote 650b Plus (compatibile 29").
- Telaio in fibra di carbonio Smoothwall.
- Carro in lega leggera Form (solo Carbon 50).
- Sistema Ride9 per regolazione geometria.
- 4 taglie: S, M, L, XL.
- Colore: Fox Racing Orange-Back in Black,
Raining Blood-Blue Monday (Pipeline Plus Carbon 70)
Raining Blood-Blue Monday (Pipeline Plus Carbon 50).





PIPELINE 27,5 PLUS
CARBON 70

PIPELINE 27,5 PLUS
CARBON 50

Frame	SMOOTHWALL™ Carbon RIDE-9™ Adjustable Geometry	SMOOTHWALL™ Carbon RIDE-9™ Adjustable Geometry
Shock	Fox Float DPS EVOL Performance Elite 140mm	Fox Float DPS EVOL Performance 140mm
Fork	Fox 34 Float Performance Elite 140mm	Fox 34 Float Performance 140mm
R. Derailleur	Sram GX Eagle	Sram GX Eagle
F. Derailleur	Rocky Mountain Spirit Guide	Rocky Mountain Spirit Guide
Chainguide	-	-
Shifters	Sram GX Eagle	Sram GX Eagle
Brakes	Shimano XT	Sram Level TL
Rotors	-	-
Crankset	Sram Stylo 7k Eagle 32T	Sram Stylo 6k Eagle 32T
Cassette	Sram XG-1275 10-50T	Sram XG-1275 10-50T
Chain	Sram GX Eagle	Sram GX Eagle
Handlebar	Race Face Turbine R 780mm	Rocky Mountain AM 760mm
Stem	Rocky Mountain 35 AM	Rocky Mountain AM
Grips	Rocky Mountain Lock On XC	Rocky Mountain Lock On Light
Headset	FSA Orbit NO.57E Extend-o-matic	FSA Orbit NO.57E Extend-o-matic
Seatpost	Fox Transfer Performance Elite 30.9mm	Fox Transfer Performance Elite 30.9mm
Saddle	WTB Silverado Race	WTB Volt Race
Front Tire	Maxxis Minion DHF Maxx Terra 3C Tubeless Ready 27.5 x 2.8	Maxxis DHF EXO Tubeless Ready 27.5 x 2.8
Rear Tire	Maxxis Minion DHR II Maxx Terra 3C Tubeless Ready 27.5 x 2.8	Maxxis DHR EXO Tubeless Ready 27.5 x 2.8
Tubes/Sealant	-	-
Front Hub	Rocky Mountain Sealed Boost 15mm	Rocky Mountain Sealed Boost 15mm
Rear Hub	DT Swiss 370 Boost 148mm	DT Swiss 370 Boost 148mm
Rim	Stans Baron S1 Tubeless Ready - Tape / Valves incl.	Sun Duroc 40 Tubeless Ready - Tape / Valves incl.
Spokes	WTB 1.8-1.6	WTB 1.8-1.6
Prezzo bici	€6.299,00	€4.999,00



ALTITUDE 27,5

Fintanto che non c'era la Slayer, la Rocky Mountain Altitude è stata la bici da enduro della casa. Poi è arrivata quella bestia della nuova Slayer e la Altitude è stata aggiornata, pur restando fedele alle sue caratteristiche: 150 mm di escursione al posteriore (con forcella da 160 mm), geometria aggressiva con angolo di sterzo da 65-66° e reach maggiorato, sistema Ride9 e gomme 27,5" con standard Wide Trail di Maxxis, ossia un po' più larghe senza essere delle Plus. Il risultato?

La nuova Rocky Mountain Altitude è ancora più divertente e capace...

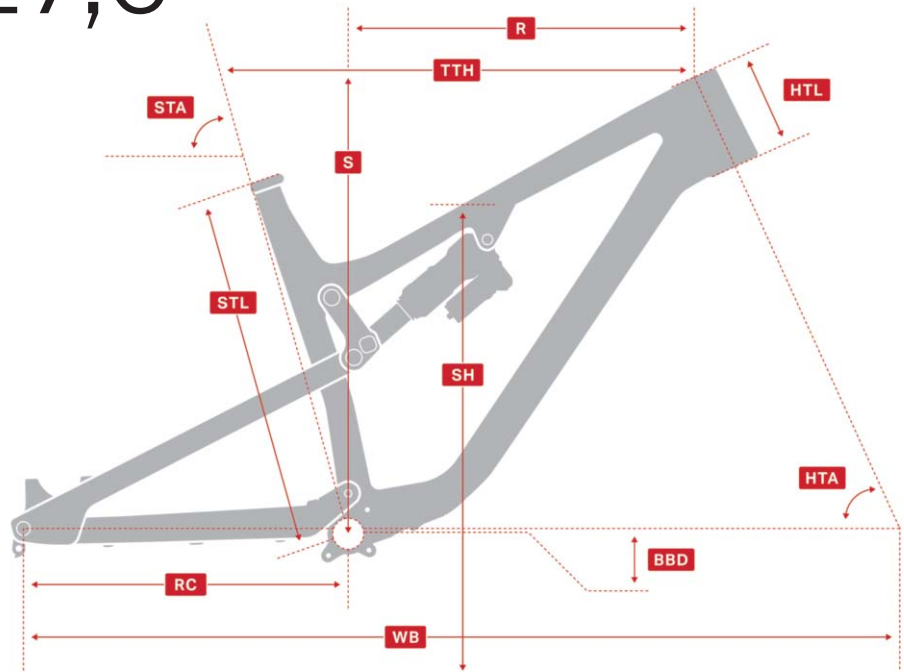

GEOMETRIA

	XS	S	M	L	XL
TTH Top Tube Horizontal (mm)	548	578	603	628	658
HTA Head Tube Angle (deg)	65	65	65	65	65.1
HTL Head Tube Length (mm)	100	110	120	130	145
STA Seat Tube Angle (deg)	74	74	74	74	74.1
STL Seat Tube Length (mm)	368	394	432	470	508
RC Rear Centre (mm)	426	426	426	426	426
BBD Bottom Bracket Drop (mm)	13	14	14	14	14
R Reach (mm)	379	407	430	452	479
S Stack (mm)SH	586	595	604	614	628
SH Standover Height (mm)	814	814	814	814	814
WB Wheelbase (mm)	1122	1153	1180	1206	1239

CARATTERISTICHE

- Travel posteriore di 150 mm.
- Travel anteriore di 160 mm.
- Ruote 27,5" Wide Trail (o 26" Plus).
- Telaio in fibra di carbonio Smoothwall o in lega leggera Form.
- Carro in lega leggera Form (solo Carbon 50, Alloy 50 e Alloy 30).
- Sistema Ride9 per regolazione geometria.
- 5 taglie: XS, S, M, L, XL.
- Colore: Billy Ocean-Raining Blood, Back in Black-Orange Crush.





ALTITUDE 27,5
CARBON 90

ALTITUDE 27,5
CARBON 70 SHIMANO

ALTITUDE 27,5
CARBON 50

Frame	SMOOTHWALL™ Carbon RIDE-9™ Adjustable Geometry	SMOOTHWALL™ Carbon RIDE-9™ Adjustable Geometry	SMOOTHWALL™ Carbon RIDE-9™ Adjustable Geometry
Shock	Fox Float DPX2 Factory 150mm	Fox Float DPS EVOL Performance Elite 150mm	Fox Float DPS EVOL Performance 150mm
Fork	Fox 36 Float EVOL FIT4 Factory 160mm	Fox 36 Float EVOL FIT4 Performance Elite 160mm	Fox 36 Float EVOL Grip Performance 160mm
R. Derailleur	Sram X01 Eagle 12 spd	Shimano XT	Shimano XT
F. Derailleur	Rocky Mountain Spirit Guide	Rocky Mountain Spirit Guide	Rocky Mountain Spirit Guide
Chainguide	-	-	-
Shifters	Sram X01 Eagle	Shimano XT	Shimano SLX
Brakes	Sram Guide RSC	Shimano XT	Shimano SLX
Rotors	180mm	180mm	180mm
Crankset	Sram Descendant Carbon Eagle 34T	Race Face Turbine Cinch 32T	Race Face Aeffect Cinch 32T Steel
Cassette	Sram XG-1295 10-50T	Shimano XT 11-46T	Shimano XT 11-46T
Chain	Sram X01 Eagle	Shimano HG-600	KMC X11-1
Handlebar	Race Face Next R 780mm	Race Face Turbine R 780mm	Race Face Chester 780mm
Stem	Rocky Mountain 35 CNC	Rocky Mountain 35 AM	Rocky Mountain 35 AM
Grips	Rocky Mountain Lock On XC	Rocky Mountain Lock On XC	Rocky Mountain Lock On XC
Headset	FSA Orbit NO.57E	FSA Orbit NO.57E	FSA Orbit NO.57E
Seatpost	Fox Transfer Factory 30.9mm	Fox Transfer Performance Elite 30.9mm	Fox Transfer Performance Elite 30.9mm
Saddle	WTB Silverado Race	WTB Silverado Race	WTB Volt Race
Front Tire	Maxxis Minion DHF WT Maxx Terra 3C Tubeless Ready 27.5 x 2.5	Maxxis Minion DHF WT Maxx Terra 3C Tubeless Ready 27.5 x 2.5	Maxxis Minion DHF WT EXO Tubeless Ready 27.5 x 2.5
Rear Tire	Maxxis Minion DHR II WT Maxx Terra 3C Tubeless Ready 27.5 x 2.4	Maxxis Minion DHR II WT Maxx Terra 3C Tubeless Ready 27.5 x 2.4	Maxxis Minion DHR II WT EXO Tubeless Ready 27.5 x 2.4
Tubes/Sealant	-	-	-
Front Hub	Rocky Mountain Sealed Boost 15mm	Rocky Mountain Sealed Boost 15mm	Rocky Mountain Sealed Boost 15mm
Rear Hub	DT Swiss 350 Boost 148mm	DT Swiss 370 Boost 148mm	DT Swiss 370 Boost 148mm
Rim	Stans Flow MK3 Tubeless Ready - Tape / Valves incl.	Stans Flow MK3 Tubeless Ready - Tape / Valves incl.	Sun Duroc 30 Tubeless Compatible - Tape / Valves / Sealant not incl.
Spokes	WTB 1.8-1.6	WTB 1.8-1.6	WTB 1.8-1.6
Prezzo telaio	€3.699,00	-	-
Prezzo bici	€8.199,00	€5.999,00	€4.899,00



ALTITUDE 27,5
Alloy 50

ALTITUDE 27,5
Alloy 30

Frame	FORM™ Alloy RIDE-9™ Adjustable Geometry	FORM™ Alloy RIDE-9™ Adjustable Geometry
Shock	Fox Float DPS EVOL Performance 150mm	RockShox Deluxe RT 150mm
Fork	Fox 36 Float EVOL Grip Performance 160mm	RockShox 2018 Yari RC 160mm
R. Derailleur	Shimano XT	Sram NX
F. Derailleur	Rocky Mountain Spirit Guide	Rocky Mountain Spirit Guide
Chainguide	-	-
Shifters	Shimano SLX	Sram NX
Brakes	Shimano SLX	Sram Level
Rotors	180mm	180mm
Crankset	Race Face Aeffect Cinch 32T Steel	Race Face Aeffect Cinch 32T Steel
Cassette	Shimano XT 11-46T	Sram PG-1130 11-42T
Chain	KMC X11-1	Sram PC-1110
Handlebar	Race Face Chester 780mm	Race Face Chester 780mm
Stem	Rocky Mountain 35 AM	Rocky Mountain 35 AM
Grips	Rocky Mountain Lock On XC	Rocky Mountain Lock On Light
Headset	FSA Orbit NO.57E	FSA Orbit NO.57E
Seatpost	Fox Transfer Performance Elite 30.9mm	Race Face Aeffect Dropper 30.9mm
Saddle	WTB Volt Race	WTB Volt Race
Front Tire	Maxxis Minion DHF WT EXO Tubeless Ready 27.5 x 2.5	Maxxis Minion DHF WT EXO Tubeless Ready 27.5 x 2.5
Rear Tire	Maxxis Minion DHR II WT EXO Tubeless Ready 27.5 x 2.4	Maxxis Minion DHR II WT EXO Tubeless Ready 27.5 x 2.4
Tubes/Sealant	-	-
Front Hub	Shimano SLX Boost 15mm	Rocky Mountain Sealed Boost 15mm
Rear Hub	Shimano SLX Boost 148mm	Sram MTH 746 Boost 148mm
Rim	Sun Duroc 30 Tubeless Compatible - Tape / Valves / Sealant not incl.	Sun Duroc 30 Tubeless Compatible - Tape / Valves / Sealant not incl.
Spokes	WTB 2.0-1.8	WTB 2.0
Prezzo bici	€3.999,00	€3.499,00



SLAYER

Ecco, questa è l'apoteosi di una bici da enduro, di una bici per il divertimento totale in discesa ovunque si voglia, da bike park, da slopestyle e via dicendo.

Quando Rocky Mountain ha riprogettato la Slayer ha pensato alla vecchia versione, ma aveva chiaro in mente come doveva essere la nuova.

Una bestia completamente diversa. Ed ecco allora il telaio in fibra di carbonio Smoothwall, un nuovo sistema Ride4 (più semplice e comunque efficace), sospensione Smoothlink capace di ben 165 mm di corsa e... tutto il resto dipende dal coraggio di chi sta in sella.

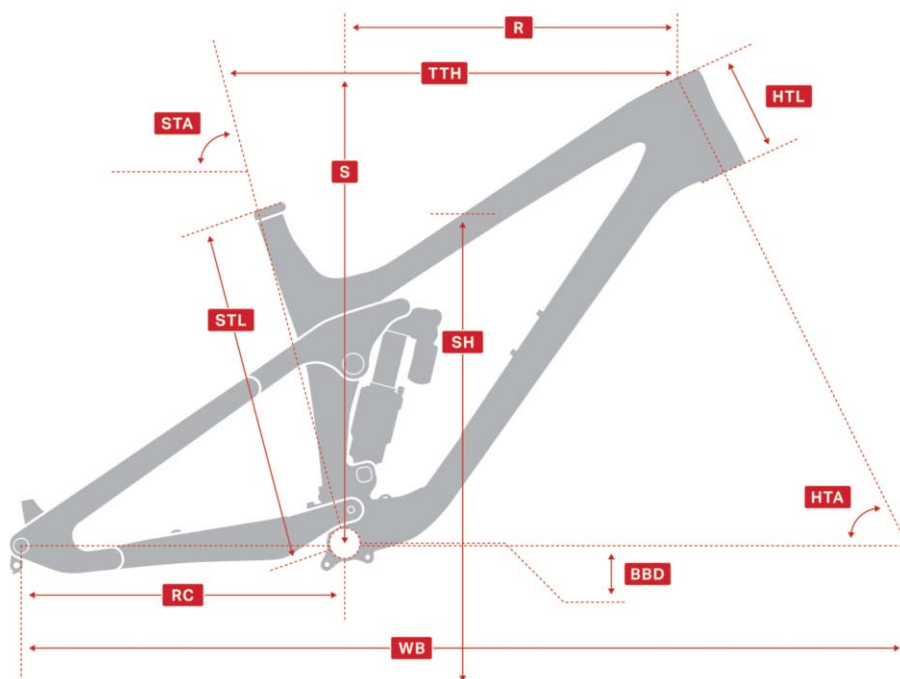

GEOMETRIA

	S	M	L	XL
TTH Top Tube Horizontal (mm)	576	601	627	657
HTA Head Tube Angle (deg)	65	65	65	65
HTL Head Tube Length (mm)	110	125	140	155
STA Seat Tube Angle (deg)	74	74	74	74
STL Seat Tube Length (mm)	394	432	470	509
RC Rear Centre (mm)	429	429	429	429
BBD Bottom Bracket Drop (mm)	12	12	12	12
R Reach (mm)	404	425	446	472
S Stack (mm)	602	616	629	643
SH Standover Height (mm)	820	820	820	820
WB Wheelbase (mm)	1,157	1,184	1,211	1,244

CARATTERISTICHE

- Travel posteriore di 165 mm.
- Travel anteriore di 170 mm.
- Ruote 27,5" Wide Trail (o 26" Plus).
- Telaio in fibra di carbonio Smoothwall.
- Carro in lega leggera Form (solo Carbon 50 e Carbon 30).
- Sistema Ride4 per regolazione geometria.
- 4 taglie: S, M, L, XL.
- Colore: Acid Rain-Raining Blood, Smoke on the Water-Back in Black.





	SLAYER CARBON 90	SLAYER CARBON 70	SLAYER CARBON 50	SLAYER CARBON 30
Frame	SMOOTHWALL™ Carbon RIDE-4™ Adjustable Geometry	SMOOTHWALL™ Carbon RIDE-4™ Adjustable Geometry	SMOOTHWALL™ Carbon RIDE-4™ Adjustable Geometry	SMOOTHWALL™ Carbon RIDE-4™ Adjustable Geometry
Shock	Fox Float DPX2 Factory 165mm	Fox Float DPX2 Performance Elite 165mm	Fox Float DPX2 Performance 165mm	RockShox Deluxe RT 165mm
Fork	Fox 36 Float EVOL FIT4 Factory 170mm	Fox 36 Float EVOL FIT4 Performance Elite 170mm	Fox 36 Float EVOL FIT4 Performance 170mm	RockShox 2018 Yari RC 170mm
R. Derailleur	Sram X01 Eagle	Sram GX Eagle	Shimano XT	Sram NX
F. Derailleur	Rocky Mountain Spirit Guide/ e*Thirteen LG1+ Bash Only	Rocky Mountain Spirit Guide/ e*Thirteen LG1+ Bash Only	Rocky Mountain Spirit Guide/ e*Thirteen LG1+ Bash Only	Rocky Mountain Spirit Guide/ e*Thirteen LG1+ Bash Only
Chainguide	-	-	-	-
Shifters	Sram X01 Eagle	Sram GX Eagle	Shimano SLX	Sram NX
Brakes	Sram Guide RSC	Sram Guide RS	Shimano SLX	Sram Guide R
Rotors	-	-	-	-
Crankset	Sram Descendent 7k Eagle 34T	Sram Descendent 7k Eagle 34T	Race Face Aeffect Cinch 32T Steel	Race Face Aeffect Cinch 32T Steel
Cassette	Sram XG-1295 10-50T	Sram XG-1275 10-50T	Shimano SLX 11-46T	Sram PG-1130 11-42T
Chain	Sram GX Eagle	Sram GX Eagle	Shimano HG-600	Sram PC-1110
Handlebar	Race Face SixC 800mm	Race Face Atlas 800mm	Race Face Chester 780mm	Race Face Chester 780mm
Stem	Rocky Mountain 35 CNC DH	Rocky Mountain 35 AM	Rocky Mountain 35 AM	Rocky Mountain 35 AM
Grips	Rocky Mountain Lock On XC	Rocky Mountain Lock On XC	Rocky Mountain Lock On XC	Rocky Mountain Lock On Light
Headset	FSA Orbit NO.57E	FSA Orbit NO.57E	FSA Orbit NO.57E	FSA Orbit NO.57E
Seatpost	Fox Transfer Factory 30.9mm	Fox Transfer Performance Elite 30.9mm	Race Face Turbine Dropper 30.9mm	Race Face Aeffect Dropper 30.9mm
Saddle	WTB Silverado Race	WTB Silverado Race	WTB Volt Race	WTB Volt Race
Front Tire	Maxxis Minion DHF Maxx Grip 3C Tubeless Ready 27.5 x 2.5	Maxxis Minion DHF Maxx Grip 3C Tubeless Ready 27.5 x 2.5	Maxxis Minion DHF EXO Tubeless Ready 27.5 x 2.5	Maxxis Minion DHF EXO Tubeless Ready 27.5 x 2.5
Rear Tire	Maxxis Minion DHR II Maxx Terra 3C Tubeless Ready 27.5 x 2.4	Maxxis Minion DHR II Maxx Terra 3C Tubeless Ready 27.5 x 2.4	Maxxis Minion DHR II EXO Tubeless Ready 27.5 x 2.4	Maxxis Minion DHR II EXO Tubeless Ready 27.5 x 2.4
Tubes/Sealant	-	-	-	-
Front Hub	Rocky Mountain Sealed Boost 15mm	Rocky Mountain Sealed Boost 15mm	Shimano M618 Boost 15mm	Rocky Mountain Sealed Boost 15mm
Rear Hub	DT Swiss 350 Boost 148mm	DT Swiss 370 Boost 148mm	Shimano M618 Boost 148mm	Sram MTH 746 Boost 148mm
Rim	Stans Flow MK3 - Tubeless Ready - Tape / Valves incl.	Stans Flow MK3 - Tubeless Ready - Tape / Valves incl.	Sun Duroc 35 - Tubeless Compatible - Tape / Valves / Sealant not incl.	Alex Volar 3.0 - Tubeless Compatible - Tape / Valves / Sealant not incl.
Spokes	WTB 1.8-1.6	WTB 1.8-1.6	WTB 2.0-1.8	WTB 2.0
Prezzo telaio	€4.199,00	-	-	-
Prezzo bici	€8.599,00	€6.899,00	€5.499,00	€4.799,00

VERTEX

E' la hardtail da cross country di casa Rocky Mountain ed è pensata per chi cerca un mezzo facile da usare e gestire e con un rapporto qualità/prezzo molto valido.

Il telaio è in lega leggera 6061 SL e la geometria è ampiamente ispirata agli altri modelli della casa per dare la massima confidenza nella guida offroad.

A ciò si aggiunge il diametro di 29" per le ruote ed ecco che il risultato diventa molto interessante.

5 le taglie disponibili e due gli allestimenti previsti, entrambi per andare in contro alle necessità di chi vuole una bici facile.

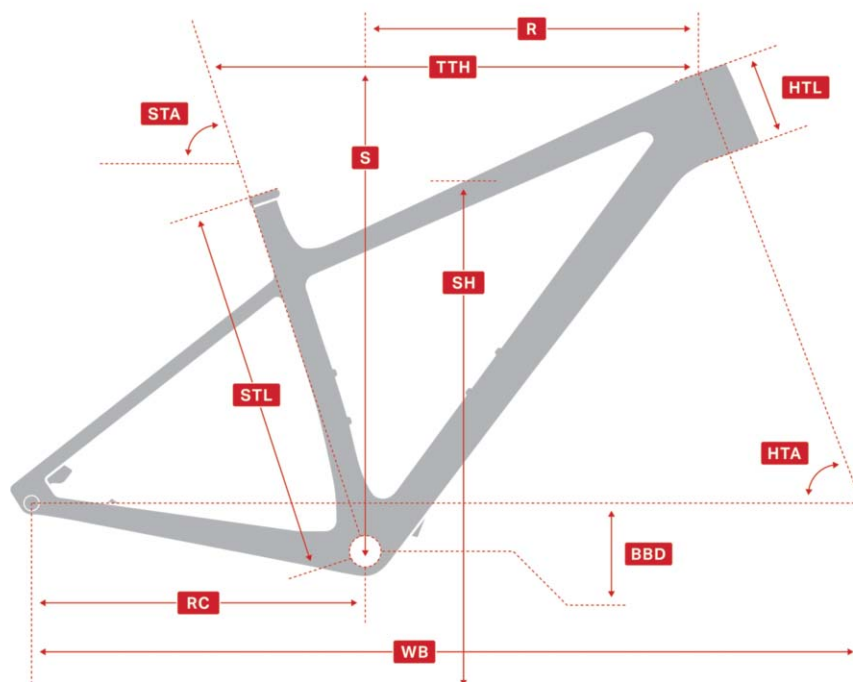

GEOMETRIA

	XS	S	M	L	XL
HTA Head Tube Angle (deg)	69.5°	70.25°	70.25°	70.25°	70.25°
STA Seat Tube Angle (deg)	74°	73°	73°	73°	73°
STL Seat Tube Length (mm)	355	394	432	470	508
TTH Top Tube Horizontal (mm)	550	570	592	615	638
HTL Head Tube Length (mm)	100	95	100	115	130
RC Rear Centre (mm)	435	435	435	435	435
BBD Bottom Bracket Drop (mm)	56	56	56	56	56
SH Standover Height (mm)	719	738	752	776	808
WB Wheelbase (mm)	1068	1065	1087	1111	1134
R Reach (mm)	381	384	405	424	442
S Stack (mm)	587	607	612	626	640

CARATTERISTICHE

- Travel anteriore di 100 mm (80 mm su taglia XS).
- Ruote 29".
- Telaio in lega leggera 6061 SL.
- Movimento centrale PF92.
- Passaggio interno dei cavi.
- 5 taglie: XS, S, M, L, XL.
- Colore: Orange Crush-Back in Black (Vertex Alloy 50)
Billy Ocean-Back in Black (Vertex Alloy 30).





VERTEX Alloy 50

VERTEX Alloy 30

	VERTEX Alloy 50	VERTEX Alloy 30
Frame	Rocky Mountain 6061 SL Series Alloy	Rocky Mountain 6061 SL Series Alloy
Shock	-	-
Fork	Rockshox Reba RL 100mm (XS: 80mm)	RockShox 30 Gold Fast Black TK Air 100mm (XS: 80mm)
R. Derailleur	Shimano XT	Shimano XT
F. Derailleur	Shimano XT	Shimano SLX
Chainguide	-	-
Shifters	Shimano XT	Shimano SLX
Brakes	Shimano SLX	Shimano SLX
Rotors	Shimano RT54 180 / 160mm	Shimano RT54 160mm
Crankset	Race Face Aeffect SL Cinch 38/28T	FSA Comet Modular 38/28T
Cassette	Shimano SLX 11-40T	Shimano SLX 11-40T
Chain	Shimano HG-600	KMC X11-1
Handlebar	Rocky Mountain XC 720mm	Rocky Mountain XC 720mm
Stem	Rocky Mountain AM	Rocky Mountain AM
Grips	Rocky Mountain Lock On Light	Rocky Mountain Lock On Light
Headset	FSA Orbit NO.57E	FSA Orbit NO.57E
Seatpost	Rocky Mountain SL 27.2mm	Rocky Mountain SL 27.2mm
Saddle	WTB Volt Race	WTB Volt
Front Tire	Maxxis Ikon Folding 29 x 2.2	Maxxis Ikon Folding 29 x 2.2
Rear Tire	Maxxis Ikon Folding 29 x 2.2	Maxxis Ikon Folding 29 x 2.2
Tubes/Sealant	-	-
Front Hub	Shimano M618 15mm	Shimano M3050
Rear Hub	Shimano M615	Shimano M3050
Rim	Sun Helix TR25 SL	WTB SX19
Spokes	WTB 2.0-1.8	2.0 Stainless
Prezzo bici	ND	ND



MAIDEN

Disegnata per il massimo livello di prestazioni in discesa, tanto per le gare di Dh quanto per il freeride e il bike park, la Rocky Mountain Maiden ha le dimensioni monster di un mezzo estremo.

Il telaio interamente in fibra di carbonio Smoothwall, la sospensione SmoothLink da 200 mm, il sistema Ride4, l'allestimento con trasmissione Sram dedicata alla Dh e l'angolo di sterzo da 63°-63,8° rendono la Maiden un mezzo che è destinato a ridisegnare i connotati di una Mtb da downhill.

Incute timore reverenziale? Bene, allora siete pronti a guidarla...

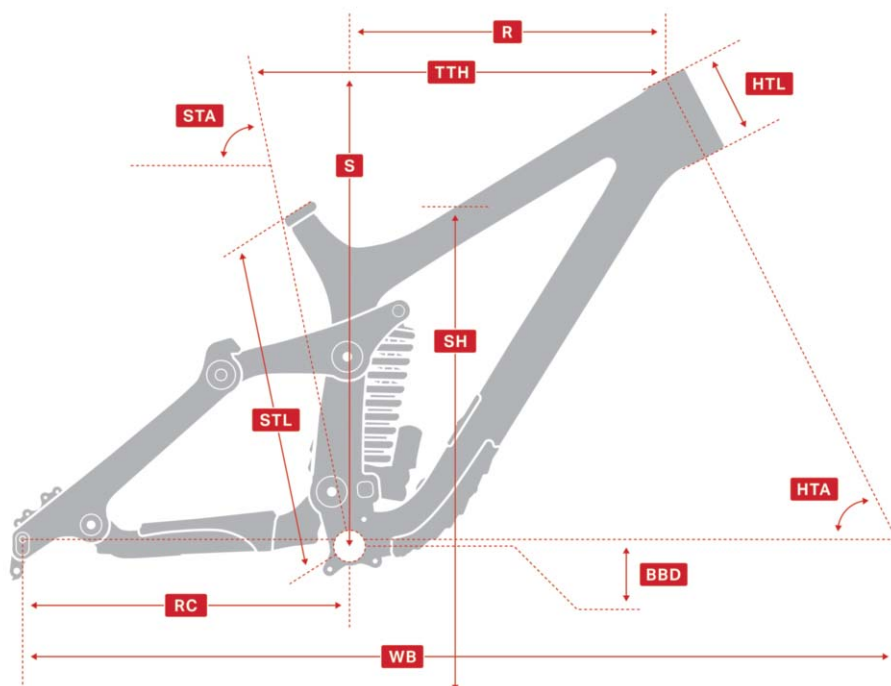

GEOMETRIA

	S	M	L	XL
TTH Top Tube Horizontal (mm)	571	589	603	621
HTA Head Tube Angle (deg)	63	63	63	63
HTL Head Tube Length (mm)	115	115	115	115
STA Seat Tube Angle (deg)	74	74	74	74
STL Seat Tube Length (mm)	406	432	457	457
RC Rear Centre (mm)	425	425	425	425
BBD Bottom Bracket Drop (mm)	9	9	9	9
R Reach (mm)	396	414	428	446
S Stack (mm)	611	611	611	611
SH Standover Height (mm)	820	820	820	820
WB Wheelbase (mm)	1,188	1,206	1,220	1,238

CARATTERISTICHE

- Travel posteriore di 200 mm.
- Travel anteriore di 200 mm.
- Ruote 27,5" (o 26").
- Telaio interamente in fibra di carbonio Smoothwall.
- Sistema Ride4 per regolazione geometria.
- 4 taglie: S, M, L, XL.
- Trasmissione Sram XO DH.
- Freni Sram Code.
- Gomma posteriore Maxxis High Roller II.
- Colore: Billy Ocean-Orange Crush,
Tank Girl-Back in Black (Maiden Carbon 90 / Carbon 30)
Tank Girl-Back in Black (Maiden Carbon 70).





MAIDEN CARBON 90

MAIDEN CARBON 50

MAIDEN CARBON 30

	MAIDEN CARBON 90	MAIDEN CARBON 50	MAIDEN CARBON 30
Frame	SMOOTHWALL™ Carbon RIDE-4™ Adjustable Geometry	SMOOTHWALL™ Carbon RIDE-4™ Adjustable Geometry	SMOOTHWALL™ Carbon RIDE-4™ Adjustable Geometry
Shock	Fox DHX2 Factory 200mm	Fox DHX2 Performance 200mm	Fox Van RC
Fork	Fox 40 Float Factory 200mm	Fox 40 Performance Elite 200mm	RockShox Boxxer RC 200mm
R. Derailleur	Sram X0 DH	Sram GX	Sram X7
F. Derailleur	e*Thirteen LG1	e*Thirteen LG1	e*Thirteen LG1
Chainguide	-	-	-
Shifters	Sram X0 DH	Sram GX	Sram X5
Brakes	Sram Code RSC	Sram Guide RE	Sram Guide RE
Rotors	-	-	-
Crankset	Race Face Atlas Cinch 165mm 34T	Race Face Respond 165mm 34T	Race Face Chester 165mm 34T
Cassette	Sram PG-720 11-25T	Sram PG-1030 11-28T	Sram PG-951 11-25T
Chain	Sram PC-1110	KMC X10-1	Sram PC-951
Handlebar	Race Face Atlas 800mm	Race Face Chester 780mm	Race Face Chester 780mm
Stem	Rocky Mountain 35 CNC DH	Rocky Mountain 35 CNC DH	Rocky Mountain 35 CNC DH
Grips	Rocky Mountain Lock On DH	Rocky Mountain Lock On DH	Rocky Mountain Lock On DH
Headset	FSA Orbit C-40	FSA Orbit C-40	FSA Orbit C-40
Seatpost	Rocky Mountain SL 30.9mm	Rocky Mountain SL 30.9mm	Rocky Mountain SL 30.9mm
Saddle	WTB Silverado Race	WTB Silverado Race	WTB Volt
Front Tire	Maxxis Minion DHF Super Tacky 27.5 x 2.5	Maxxis Minion DHF Super Tacky 27.5 x 2.5	Maxxis Minion DHF Super Tacky 27.5 x 2.5
Rear Tire	Maxxis Minion DHR11 Maxx Grip 3C 27.5 x 2.4	Maxxis High Roller 27.5 x 2.4	Maxxis High Roller 27.5 x 2.4
Tubes/Sealant	-	-	-
Front Hub	Rocky Mountain Sealed 20mm	Rocky Mountain Sealed 20mm	Rocky Mountain Sealed 20mm
Rear Hub	DT Swiss 350 157mm	Rocky Mountain Sealed 157mm	Rocky Mountain Sealed 157mm
Rim	Sun Helix TR29 - Tubeless Compatible - Tape / Valves / Sealant not Incl.	Sun Helix TR29 - Tubeless Compatible - Tape / Valves / Sealant not incl.	Sun Helix TR29 - Tubeless Compatible - Tape / Valves / Sealant not incl.
Spokes	WTB 2.0-1.8	WTB 2.0	WTB 2.0
Prezzo telaio	€4.499,00	-	-
Prezzo bici	€8.299,00	€6.499,00	€4.999,00



Ti piace questa bici? Allora mettiti seduto e leggi questa storia

Ti piace questa bici?

Allora, mettiti seduto e leggi questa storia.

La Rocky Mountain Altitude Powerplay non è una Mtb e non è nemmeno una e-Bike di quelle che trovi ovunque.

È diversa dalla Turbo Levo, dalla Haibike, dalla Moustache e da tutte quelle che, oggi, ti possono venire in mente.

È, appunto, una storia a parte, perché Rocky Mountain ha

voluto che questa bici avesse una storia.

E ad una storia, per funzionare, servono alcuni elementi chiave:

- il soggetto;
- il dramma;
- il sole dopo la tempesta, cioè la gioia;
- e il nocciolino da masticare alla fine.





E questa bici ha una storia completa. Il soggetto, cioè la creazione della prima Mtb a pedalata assistita da parte di Rocky Mountain, è una strada tortuosa che porta in un posto magnifico. Come succede quando sei in montagna: la fatica, prima o poi, ti dà una ricompensa che supera di gran lunga il tuo sudore. E il soggetto Rocky Mountain l'ha scelto molto bene, come

si farebbe con un single track che sale. Il dramma, anzi, i drammi. La paura di aver scelto la strada sbagliata, troppo tortuosa, troppo difficile, troppo dispendiosa, mentre là fuori gli altri marchi, intanto, uscivano con le loro e-Bike. Più o meno raffinate, certo, ma intanto uscivano e iniziavano a vendere prima del marchio canadese. Il telaio in fibra di carbonio, il motore sviluppato e prodotto



Se vuoi che gli altri ti
riconoscano, fai le cose
in modo diverso.
E Rocky ha scelto
un modo davvero
epico.



in casa, la geometria quanto più vicina a quella di una Altitude e soprattutto la batteria da 632 Wh sono stati per un certo tempo e per innumerevoli volte un dramma per Rocky Mountain.

Ma se ti fai spaventare dalla salita, la salita vince.

E Rocky Mountain ha fatto come il più tenace dei biker: ha insistito.

E alla fine ecco il sole

Sì, la Altitude Powerplay finalmente esiste e funziona anche come Rocky Mountain aveva voluto.

Il sentiero in salita lungo e tortuoso è conquistato.

Chi ha avuto il piacere di provarla ne è rimasto stupito: non è come le altre e-Bike, è davvero un mondo a parte.

E' più pronta delle altre, perché basta che poggi un piede sul pedale per sentire che il motore elettrico ha capito che ci sei ed inizia subito ad assisterti.

Modulabile tramite un'applicazione, se vuoi.

E la geometria?

E il telaio in fibra di carbonio?

E la batteria da 632 Wh?

Sono cose che oggi ancora fanno parte di uno standard lontano nel tempo.

Parliamo del futuro, insomma.

Morale della favola?

Ecco il nocciolino: se vuoi che gli altri ti riconoscano, fai le cose in modo diverso.

E se sei un marchio come Rocky Mountain farle in modo

diverso significa, come è successo per la Altitude

Powerplay, scegliere un sentiero difficile, ma dannatamente epico.



EVIL



dsb

SEMPLICEMENTE BICI



Evil è diventata Evil grazie a tre bici: la Undead e la Uprising, entrambe 26", ossia le prima full con sospensione Delta System, e, poi, la Following, 29" di pura follia.

La seconda ha portato questo piccolo marchio americano alla ribalta mondiale grazie a una trail bike 29" con un carattere da bici da Dh. Ecco perché pura follia...

Che però ha conquistato migliaia di appassionati.

Grazie all'intuizione di Dave Wiggle sulla sospensione Delta System le Evil sono delle bici fuori dagli schemi, estremamente capaci e dotate e anche personalizzabili. Tutte infatti hanno la regolazione dell'angolo di sterzo ed è da lì che si inizia a giocare...

THE FOLLOWING MB

La The Following è la bici che ha definitivamente rilanciato le 29er in un ambito che non fosse solo Xc o enduro. Telaio in fibra di carbonio, 120 mm di escursione che, con lo schema Delta System, sembrano non finire mai, geometria davvero cattiva, standard Boost, ammortizzatore con sistema metrico, geometria regolabile su due posizioni (Low ed X-Low) e, per finire, attacco per il portaboraccia sul tubo obliquo. Con una forcella da 140 mm e un paio di ruote molto reattive questa trail bike da 120 mm vi farà parcheggiare in garage la vostra full da enduro. Scommettiamo?

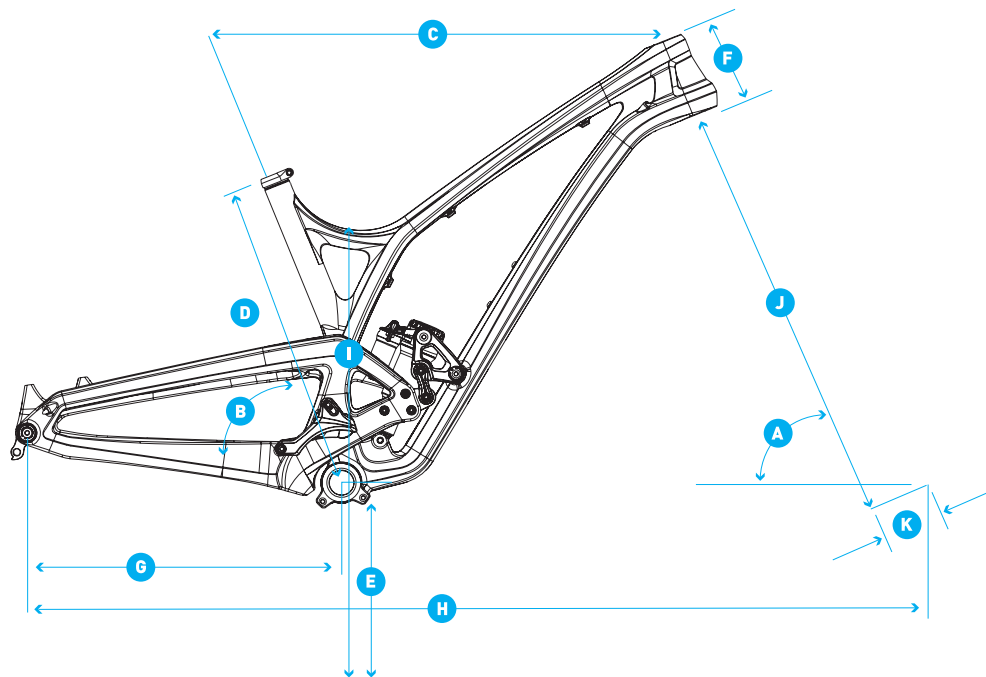

GEOMETRIA

(Forcella da 130mm)

	S	M	L	XL
A - Head Angle Low	67.4°	67.4°	67.4°	67.4°
Head Angle X-Low	66.8°	66.8°	66.8°	66.8°
B - Seat Tube Angle Low	74.3°	74.3°	74.3°	74.3°
Seat Tube Angle X-Low	73.7°	73.7°	73.7°	73.7°
C - Virtual Top Tube Length	582mm	605mm	622mm	641mm
D - Seat Tube Length	381mm	432mm	470mm	508mm
E - Bottom Bracket Height Low	338mm	338mm	338mm	338mm
Bottom Bracket Height X-Low	330mm	330mm	330mm	330mm
F - Head Tube Length	90mm	110mm	110mm	120mm
G - Chain Stay Length Low	430mm	430mm	430mm	430mm
Chain Stay Length X-Low	432mm	432mm	432mm	432mm
H - Wheel Base Low	1135mm	1159mm	1177mm	1197mm
Wheel Base X-Low	1136mm	1160mm	1178mm	1198mm
I - Standover	696mm	709mm	721mm	733mm
J - Axle to Crown	531mm	531mm	531mm	531mm
K - Offset	51mm	51mm	51mm	51mm
Stack	590mm	608mm	608mm	617mm
Reach	418mm	435mm	452mm	470mm
Sizing	5'3" - 5'8"	5'8" - 6'0"	6'0" - 6'4"	6'4" +

CARATTERISTICHE

- 120 mm di escursione Delta System.
- Garanzia di 3 anni sul telaio e crash replacement sul telaio.
- Compatibile con ruote 29" oppure 27,5" Plus.
- Perfetta per: sentieri veloci, tecnici e iper tecnici.
- Taglie: S - M - L - XL.
- Peso solo telaio: 3,1 kg (tg L).
- Colore: Smashing Pumpkin, Drunk Olive.
- Disponibile telaio THE FOLLOWING 29" esc.120mm, Monarch RT3.



THE FOLLOWING MB GX EAGLE

THE FOLLOWING MB X01 Eagle

Frame	120mm, UD Carbon, guidacatena superiore integrato, battuta BOOST	120mm, UD Carbon, guidacatena superiore integrato, battuta BOOST
Shock	Rockshox Super Deluxe RCT Debonair, 165x45 (+2 token), Trunion	Rockshox Super Deluxe RCT Debonair, 165x45 (+2 token), Trunion
Fork	Rockshox Pike RCT3 29, Solo Air, 130mm Travel, 51mm Offset	Rockshox Pike RCT3 29, Solo Air, 130mm Travel, 51mm Offset
R. Derailleur	SRAM X01 Eagle 12 speed	SRAM X01 Eagle 12 speed
F. Derailleur	-	-
Chainguide	-	-
Shifters	SRAM GX Eagle 12 speed	SRAM X01 Eagle 12 speed
Brakes	SRAM Guide R	SRAM Guide RSC
Rotors	Avid Center Line, 180mm	Avid Center Line, 180mm
Crankset	SRAM Descendent 6K, Direct Mount 32t ring	SRAM Eagle XO Carbon, 32t ring
Cassette	SRAM XG-1275 Eagle, 10-50t: 10, 12, 14, 16, 18, 21, 24, 28, 32, 36, 42, 50	SRAM XG-1295 Eagle, 10-50t: 10, 12, 14, 16, 18, 21, 24, 28, 32, 36, 42, 50
Chain	SRAM GX Eagle w/Powerlock	SRAM X01 Eagle w/Powerlock
Handlebar	Raceface Chester 35, Rise: 35mm Width: 780mm	Raceface SIXC Carbon 35, Rise: 35mm Width: 820mm
Stem	Raceface Aeffect R 35, Length: 40mm	Raceface Turbine R 35, Length: 50mm
Grips	Evil Lock-on	Evil Lock-on
Headset	FSA Integrated Tapered No.57/68	FSA Integrated Tapered No.57/68
Seatpost	RockShox Reverb Stealth 30.9x125mm (S), 150mm (M), 170mm (L/XL)	RockShox Reverb Stealth 30.9x125mm (S), 150mm (M), 170mm (L/XL)
Saddle	WTB Volt Pro	WTB Volt Comp
Front Tire	Maxxis Minion DHF EXO TR, 29x2.3	e*thirteen TRSr, 2.35 Sticky Triple
Rear Tire	Maxxis Minion DHR II EXO TR, 29x2.3	e*thirteen TRS+, 2.35 Durable Dual
 Tubes/Sealant	29" tubes	29" tubes
Front Hub	-	-
Rear Hub	-	-
Rim	Raceface Aeffect R	-
Spokes	-	-
Prezzo telaio	€3.199,00	€3.199,00
Prezzo bici	€5.899,00	€7.799,00



THE CALLING

Dalla Following eredita il carattere ribelle, la sospensione Delta System e le grandi capacità tecniche, ma con ruote da 27,5" e 130 mm di escursione, per incrementare l'agilità e la maneggevolezza.

La Evil The Calling è stata la prima Evil ad adottare lo standard metrico per l'ammortizzatore, un RockShox Superdeluxe Rc3 Debonair con un tuning specifico per questa bici. Non mancano la geometria regolabile e le altre peculiarità tecniche della "sorella" da 29".

La The Calling è venduta come bici completa con forcella da 140 mm oppure come frame set. A voi la scelta...

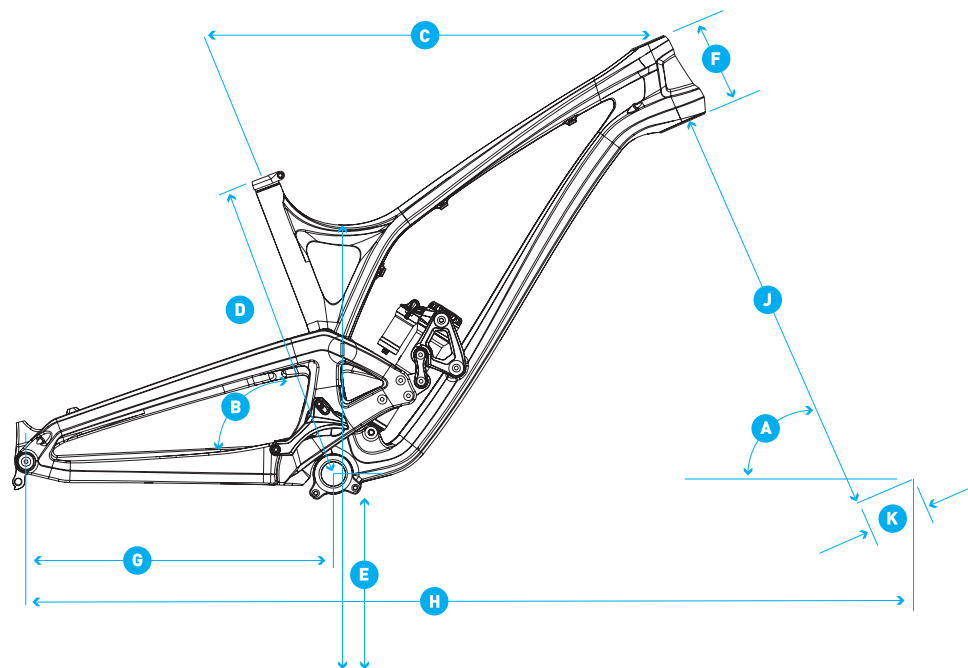

GEOMETRIA

(Forcella da 140mm)

	S	M	L	XL
A - Head Angle Low	66.4°	66.4°	66.4°	66.4°
Head Angle X-Low	65.8°	65.8°	65.8°	65.8°
B - Seat Tube Angle Low	74.8°	74.8°	74.8°	74.8°
Seat Tube Angle X-Low	74.2°	74.2°	74.2°	74.2°
C - Virtual Top Tube Length	582.5mm	603mm	624mm	644mm
D - Seat Tube Length	390mm	425mm	460mm	495mm
Bottom Bracket Height Low	338mm	338mm	338mm	338mm
E - Bottom Bracket Height X-Low	330mm	330mm	330mm	330mm
F - Head Tube Length	106mm	120mm	133mm	147mm
G - Chain Stay Length Low	430mm	430mm	430mm	430mm
Chain Stay Length X-Low	432mm	432mm	432mm	432mm
H - Wheel Base Low	1148mm	1170mm	1193mm	1216mm
Wheel Base X-Low	1150mm	1172mm	1195mm	1218mm
I - Standover	690mm	703mm	715mm	727mm
J - Axle to Crown	532mm	532mm	532mm	532mm
K - Offset	42mm	42mm	42mm	42mm
Stack	589mm	601mm	613mm	627mm
Reach	423mm	440mm	457mm	474mm
Sizing	5'3" - 5'8"	5'8" - 6'0"	6'0" - 6'4"	6'4"

CARATTERISTICHE

- 130 mm di escursione Delta System.
- Garanzia di 3 anni sul telaio.
- Ruote 27,5" oppure 26" Plus.
- Servizio di crash replacement sul telaio.
- Perfetta per: sentieri veloci, tecnici e iper tecnici.
- Taglie: S - M - L - XL.
- Colore: Aqua Matte, Muddy Waters.



THE CALLING GX EAGLE

THE CALLING X01 EAGLE

Frame	131mm, UD Carbon, guidacatena superiore integrato, battuta BOOST	131mm, UD Carbon, guidacatena superiore integrato, battuta BOOST
Shock	Rockshox Super Deluxe RC3 Debonair, 185x50 (+1 Token), Trunnion	Rockshox Super Deluxe RC3 Debonair, 185x50 (+1 Token), Trunnion
Fork	Rockshox Pike RCT3 27.5, Solo Air, 140mm Travel, 15x110	Rockshox Pike RCT3 27.5, Solo Air, 140mm Travel, 15x110
R. Derailleur	SRAM GX Eagle 12 speed	SRAM X01 Eagle 12 speed
F. Derailleur	-	-
Chainguide	-	-
Shifters	SRAM GX Eagle 12 speed	SRAM X01 Eagle 12 speed
Brakes	SRAM Guide R	SRAM Guide RSC
Rotors	Avid Center Line, 180mm	Avid Center Line, 180mm
Crankset	SRAM Descendent 6K, Direct Mount 32t ring	SRAM Eagle XO Carbon, 32t ring
Cassette	SRAM XG-1275 Eagle, 10-50t: 10, 12, 14, 16, 18, 21, 24, 28, 32, 36, 42, 50	SRAM XG-1295 Eagle, 10-50t: 10, 12, 14, 16, 18, 21, 24, 28, 32, 36, 42, 50
Chain	SRAM GX Eagle w/Powerlock	SRAM X01 Eagle w/Powerlock
Handlebar	Raceface Chester 35, Rise: 35mm Width: 780mm	Raceface NEXT R Carbon 35, Rise: 35mm Width: 780mm
Stem	Raceface Aeffect R 35, Length: 40mm	Raceface Turbine R 35, Length: 40mm
Grips	Evil Lock-on	Evil Lock-on
Headset	FSA Integrated Tapered	FSA Integrated Tapered
Seatpost	RockShox Reverb Stealth 30.9x125mm (S), 150mm (M), 170mm (L/XL)	RockShox Reverb Stealth 30.9x125mm (S), 150mm (M), 170mm (L/XL)
Saddle	WTB Volt Pro	WTB Volt Comp
Front Tire	Maxxis Minion DHF EXO TR, 27.5x2.3	e*thirteen TRSr, 2.35 Sticky Triple
Rear Tire	Maxxis Minion DHR II EXO TR, 27.5x2.3	e*thirteen TRS+, 2.35 Durable Dual
 Tubes/Sealant	27.5" tubes	27.5" tubes
Front Hub	-	-
Rear Hub	-	-
Rim	Raceface Aeffect R	e*thirteen TRS Race Carbon
Spokes	-	-
Prezzo telaio	€3.199,00	€3.199,00
Prezzo bici	€5.899,00	€7.799,00



THE INSURGENT

Quando l'enduro stava esplodendo in tutto il mondo, Evil non aveva una bici realmente da enduro. E addirittura se ne uscì con la Following. Poi, visto il successo di questo modello, lanciarono la Insurgent che in molti definirono la Uprising (ossia la precedente bici da all mountain) con ruote da 27,5". La Insurgent, però, è anche qualcosa di più perché porta in dote l'esperienza che Evil ha realizzato sulla Following: la sospensione Delta System arriva a 151 mm, compaiono il guidacatena integrato e una geometria più adatta all'uso enduro. Ed ecco qui la Insurgent, disponibile come bici completa o solo telaio.

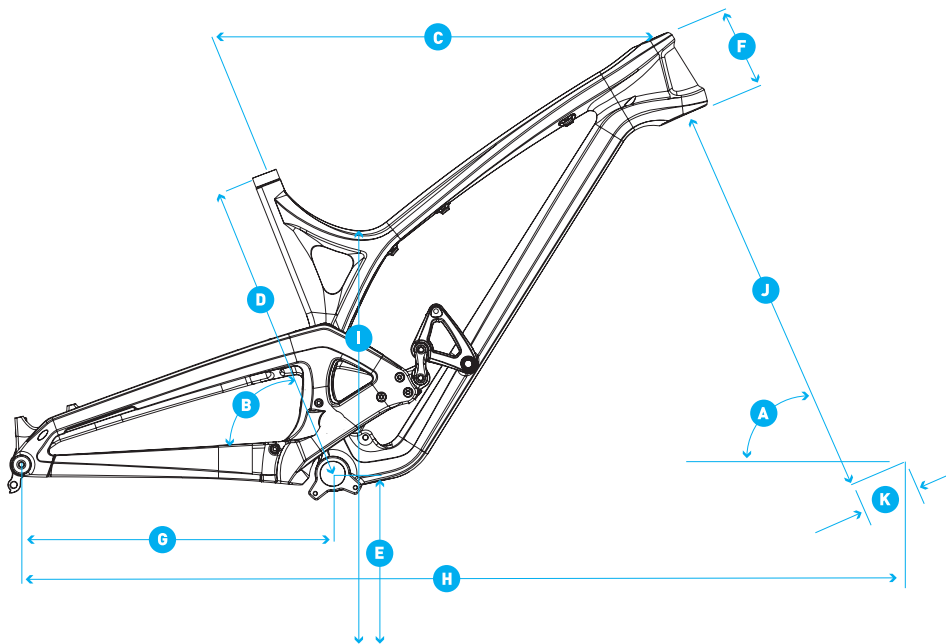

GEOMETRIA

(Forcella da 160mm)

	S	M	L	XL
A - Head Angle Low	65.6°	65.6°	65.6°	65.6°
Head Angle X-Low	64.8°	64.8°	64.8°	64.8°
B - Seat Tube Angle Low	74.3°	74.3°	74.3°	74.3°
Seat Tube Angle X-Low	73.4°	73.4°	73.4°	73.4°
C - Virtual Top Tube Length	598mm	619mm	640mm	661mm
D - Seat Tube Length	390mm	425mm	460mm	495mm
Bottom Bracket Height Low	346mm	346mm	346mm	346mm
E - Bottom Bracket Height X-Low	334.4mm	334.4mm	334.4mm	334.4mm
F - Head Tube Length	100mm	114mm	127mm	141mm
G - Chain Stay Length Low	430mm	430mm	430mm	430mm
Chain Stay Length X-Low	432mm	432mm	432mm	432mm
H - Wheel Base Low	1155mm	1178mm	1200mm	1223mm
Wheel Base X-Low	1157mm	1180mm	1202mm	1224mm
I - Standover	652mm	681mm	701mm	715mm
J - Axle to Crown	552mm	552mm	552mm	552mm
K - Offset	42mm	42mm	42mm	42mm
Stack	589mm	602mm	614mm	627mm
Reach	416mm	433mm	451mm	468mm
Sizing	5'3" - 5'8"	5'8" - 6'0"	6'0" - 6'4"	6'4"

CARATTERISTICHE

- 151 mm di escursione Delta System.
- Garanzia di 3 anni sul telaio.
- Ruote 27,5".
- Servizio di crash replacement sul telaio.
- Perfetta per: sentieri veloci, tecnici ed enduro.
- Taglie: S - M - L - XL.
- Colore: Slimeball Yellow, Murder Black.



THE INSURGENT GX EAGLE

THE INSURGENT X01 EAGLE

Frame	151mm, UD Carbon, guidacatena superiore integrato, battuta non BOOST	151mm, UD Carbon, guidacatena superiore integrato, battuta non BOOST
Shock	Rockshox Monarch Plus RC3 Debonair, 200x57 (+2 Volume Spacers)	Rockshox Monarch Plus RC3 Debonair, 200x57 (+2 Volume Spacers)
Fork	RockShox Lyrik RCT3 27.5, Solo Air, 160mm Travel, 15x100	RockShox Lyrik RCT3 27.5, Solo Air, 160mm Travel, 15x100
R. Derailleur	SRAM GX Eagle 12 speed	SRAM X01 Eagle 12 speed
F. Derailleur	-	N/A
Chainguide	-	N/A
Shifters	SRAM GX Eagle 12 speed	SRAM X01 Eagle 12 speed
Brakes	SRAM Guide R	SRAM Guide RSC
Rotors	Avid Center Line, 180mm	Avid Center Line, 180mm
Crankset	SRAM Descendent 6K, Direct Mount 32t ring	SRAM Eagle XO Carbon, 34t ring
Cassette	SRAM XG-1275 Eagle, 10-50t: 10, 12, 14, 16, 18, 21, 24, 28, 32, 36, 42, 50	SRAM XG-1295 Eagle, 10-50t: 10, 12, 14, 16, 18, 21, 24, 28, 32, 36, 42, 50
Chain	SRAM GX Eagle w/Powerlock	SRAM X01 Eagle w/Powerlock
Handlebar	Raceface Chester 35, Rise: 35mm Width: 780mm	Raceface SIXC Carbon 35, Rise: 35mm Width: 800mm
Stem	Raceface Aeffect R 35, Length: 40mm	Raceface Atlas 35, Length: 35mm
Grips	Evil Lock-on	Evil Lock-on
Headset	FSA Integrated Tapered	FSA Integrated Tapered
Seatpost	RockShox Reverb Stealth 30.9x125mm (S), 150mm (M), 170mm (L/XL)	RockShox Reverb Stealth 30.9x125mm (S), 150mm (M), 170mm (L/XL)
Saddle	WTB Volt Pro	WTB Silverado
Front Tire	Maxxis Minion DHF EXO TR, 27.5x2.3	WTB Vigilante 27.5x2.3
Rear Tire	Maxxis Minion DHR II EXO TR, 27.5x2.3	WTB Vigilante 27.5x2.3
Tubes/Sealant	27.5" tubes	27.5" tubes
Front Hub	-	-
Rear Hub	-	-
Rim	Raceface Aeffect R	Raceface Turbine R
Spokes	-	-
Prezzo telaio	€2.799,00	€2.799,00
Prezzo bici	€5.599,00	€7.499,00



THE WRECKONING

Visto ciò che la Following ha saputo creare con le ruote da 29" e visto che le 29er da enduro stavano piano tornando a essere popolari, Evil lancia la Wreckoning, ossia una Following con più escursione, più solidità, più precisione e più cattiveria ancora. Con 161 mm di escursione al posteriore questa bici, grazie anche ad accorgimenti costruttivi ereditati dal mondo Dh, riesce a raggiungere livelli di precisione e robustezza mai visti prima su un telaio da enduro. La Wreckoning è dotata di battuta Boost e di una geometria regolabile con un angolo di sterzo che varia fra 65,5° e 66,1°.

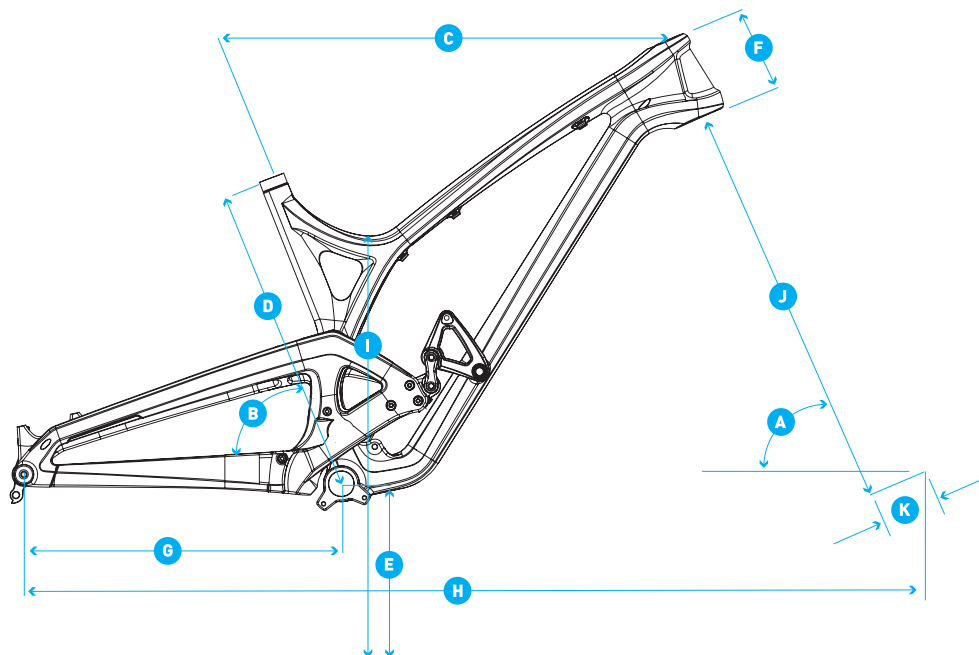

GEOMETRIA

(Forcella da 160mm)

	S	M	L	XL
A - Head Angle Low	66.1°	66.1°	66.1°	66.1°
Head Angle X-Low	65.5°	65.5°	65.5°	65.5°
B - Seat Tube Angle Low	74.8°	74.8°	74.8°	74.8°
Seat Tube Angle X-Low	73.9°	73.9°	73.9°	73.9°
C - Virtual Top Tube Length	604mm	624mm	647mm	671mm
D - Seat Tube Length	390mm	425mm	460mm	495mm
E - Bottom Bracket Height Low	348mm	348mm	348mm	348mm
Bottom Bracket Height X-Low	339mm	339mm	339mm	339mm
F - Head Tube Length	104mm	114mm	127mm	139mm
G - Chain Stay Length Low	430mm	430mm	430mm	430mm
Chain Stay Length X-Low	432mm	432mm	432mm	432mm
H - Wheel Base Low	1161mm	1182mm	1207mm	1232mm
Wheel Base X-Low	1162mm	1183mm	1208mm	1233mm
I - Standover	734mm	745mm	752mm	765mm
J - Axle to Crown	571mm	571mm	571mm	571mm
K - Offset	51mm	51mm	51mm	51mm
Stack	627mm	636mm	648mm	659mm
Reach	415mm	432mm	452mm	472mm
Sizing	5'3" - 5'8"	5'8" - 6'0"	6'0" - 6'4"	6'4"+

CARATTERISTICHE

- 161 mm di escursione Delta System.
- Garanzia di 3 anni sul telaio.
- Ruote 29".
- Servizio di crash replacement sul telaio.
- Perfetta per: sentieri veloci, iper tecnici ed enduro.
- Taglie: S - M - L - XL.
- Colore: Gunmetal Satin, Megalodon Blue.



THE WRECKONING GX EAGLE

THE WRECKONING X01 EAGLE

Frame	161mm, UD Carbon, guidacatena superiore integrato, battuta BOOST	161mm, UD Carbon, guidacatena superiore integrato, battuta BOOST
Shock	RockShox Monarch Plus RC3 Debonair, 216x63 (+2 Volume Spacers)	RockShox Monarch Plus RC3 Debonair, 216x63 (+2 Volume Spacers)
Fork	RockShox Lyrik RCT3 29, Solo Air, 160mm Travel, 15x110	RockShox Lyrik RCT3 29, Solo Air, 160mm Travel, 15x110
R. Derailleur	SRAM GX Eagle 12 speed	SRAM X01 Eagle 12 speed
F. Derailleur	-	N/A
Chainguide	-	N/A
Shifters	SRAM GX Eagle, 12 speed	SRAM X01 Eagle
Brakes	SRAM Guide R	SRAM Guide RSC
Rotors	Avid Center Line, 180mm	Avid Centerline - 180mm
Crankset	Descendent 6K, Direct Mount 32t ring	SRAM Eagle XO Carbon, 32t ring
Cassette	SRAM XG-1275 Eagle, 10-50t: 10, 12, 14, 16, 18, 21, 24, 28, 32, 36, 42, 50	SRAM XG-1295 Eagle, 10-50t: 10, 12, 14, 16, 18, 21, 24, 28, 32, 36, 42, 50
Chain	SRAM GX Eagle w/Powerlock	SRAM X01 Eagle w/Powerlock
Handlebar	Raceface Chester 35, Rise: 35mm Width: 780mm	Raceface SIXC Carbon 35, Rise: 35mm Width: 820mm
Stem	Raceface Aeffect R 35, Length: 40mm	Raceface Atlas 35, Length: 40mm
Grips	Evil Lock-on	Evil Lock-on
Headset	FSA Integrated Tapered	FSA Integrated Tapered
Seatpost	RockShox Reverb Stealth 34.9x125mm (S), 150mm (M), 170mm (L/XL)	RockShox Reverb Stealth 34.9x125mm (S), 150mm (M), 170mm (L/XL)
Saddle	WTB Volt Pro	WTB Volt Comp
Front Tire	Maxxis Minion DHF EXO TR, 29x2.3	e*thirteen TRSr, 2.35 Sticky Triple
Rear Tire	Maxxis Minion DHR II EXO TR, 29x2.3	e*thirteen TRS+, 2.35 Durable Dual
Tubes/Sealant	29" tubes	29" tubes
Front Hub	-	-
Rear Hub	-	-
Rim	Raceface Aeffect R	Santa Cruz Reserve 27 Carbon - 28h
Spokes	-	-
Prezzo telaio	€3.199,00	€3.199,00
Prezzo bici	€5.899,00	€7.899,00



OPEN



★dsb★

SEMPLICEMENTE BICI

U.P. New

SPECIFICHE

Telaio gravel, peso 1.000gr (taglia M).

Misure S, M, L, XL.

COLORI

Lime, Azzurro.

€
3.200,00



U.P.

SPECIFICHE

Telaio gravel, peso 1.100gr (taglia M).

Misure S, M, L, XL.

COLORI

Arancio, Marrone.

€
2.600,00



U.P.P.E.R.

SPECIFICHE

Telaio gravel, peso 880gr (taglia M).

Misure S, M, L, XL.

COLORI

Matte Black.

Forcella Lauf disponibile con sovrapprezzo per telai U.P. e U.P.P.E.R.

€
4.500,00



One+

SPECIFICHE

Telaio front che può essere montato sia 29 che 27.5 plus.

Misure S, M, L.

COLORI

Black.

€
3.200,00



OPEN



Una strada sterrata è una benedizione

Una strada sterrata è una benedizione.
È lenta, polverosa, impone cautela e condivisione.
Ci passi su con lo spirito con cui si entra in un luogo importante, anche se, intorno, non c'è granché di realmente sacro, di altisonante o di tanto stupefacente.
Una strada sterrata è una strada che non ha tanta fama.
La usano pochi, la conoscono anche in meno e magari la

maggior parte pensa che nemmeno serva più.
Bene!

Allora succede questo: metterci su le ruote diventa una magia.

Esci dall'asfalto liscio, o più o meno liscio, cambi rapporto e ti prepari a una velocità che sarà, forse, più bassa.
Ghiaia, sterrato, terra bianca, giallastra, marrone, erba,



pezzi di cemento e un insieme di superfici che fa l'effetto di confusione assoluta.

Però questa strada bianca è una bella storia.

Il rumore della ghiaia quando ci metti su le ruote è diverso. Non è quello che senti con la tua mountain bike, ma è più acuto perché le gomme sono più gonfie e la ghiaia risponde in modo diverso.

È tutto più immediato e veloce, anche se in realtà vai più piano.

La strada bianca è di ghiaia e di terra battuta, dura come il tempo e la forza di chi vi è passato sopra per decenni.

Poche persone, forse, ma tantissime volte.

La tua bici gravel è pensata per questi spazi, per le strade meno frequentate e per le storie indurite su quel manto di terra battuta o di asfalto abbandonato.

Non lasci impronte durature sulla ghiaia.

Ciò che lasci è un solco sottile che dura poco.

E allora, il luogo dove sei, la campagna, la montagna, la

collina, il bosco, tutto diventa un po' più sacro.

Se ci credi avviene un fatto mistico che ha del surreale.

La tua gravel bike leggera e semplice diventa il tramite con il mondo che hai intorno.

Il fine non è solo pedalare, ma sentire.

E la bici non è il fine, ma il mezzo.

Presta attenzione.

Certo, fa piacere il telaio in fibra di carbonio e anche il cambio 1x11, ma quando la tua bici gravel funziona non pensi più a queste cose.

Pensi che sei felice così, di essere lontano dal mondo e più vicino a te stesso.

Magari con gli amici veri che ti seguono in bici.

Quella è fortuna, amico mio, credi a queste parole.

La mountain bike ha iniziato proprio da lì.

Serviva la bici per andare più veloce fuoristrada.



La gravel bike è il tramite
con il mondo intorno.
Il fine non è solo pedalare,
ma sentire. E la bici non
è il fine, ma il mezzo



La gravel bike, invece, è diversa: è la bici per andare sia su asfalto che off-road.

Veloce? Sì, se vuoi.

Impugna in basso il manubrio, guarda lontano e inizia a far lavorare il cuore.

Piano? Anche, certo, magari guardandosi intorno e scrutando a terra in cerca di altre impronte di bici.

Cercando qualche altro ciclista solitario che conosca la magia della ghiaia e delle strade poco frequentate.

Poi, quando si torna su asfalto il ritmo cambia, lo sappiamo tutti, ma intanto su questa strada il tempo va più lento.

Le foglie intorno sono rivestite di polvere e senti di appartenere, per qualche istante, a un mondo antico.

Dove forse le auto ancora non esistevano.

E le bici erano un mezzo per la gloria e un mezzo di trasporto allo stesso tempo.

Sì, sono epoche lontane, ma questa strada non è cambiata molto da allora.

È sempre qui, silenziosa, polverosa, lenta, più difficile, ma benedetta da generazioni.

E io mi sento privilegiato di pedalarci sopra e anche irriverente nel farlo con una bici di epoca moderna, leggera, comoda, luccicante, facile.

Ma questa gravel bike, alla fine, è il modo più rapido per tornare indietro nel tempo e restare nel mio tempo allo stesso istante.

È una magia che si realizza quando voglio.

Basta salire in sella.

Ecco perché le strade bianche sono una benedizione.







AFTON

Afton



★dsb★

SEMPLICEMENTE BICI

Keegan

€
99,99

SPECIFICHE

Scarpa in nylon rinforzato e nabuk. Interno in materiale tecnico. Un rinforzo mono-direzionale permette di camminare normalmente ma diventa rigido se forzato nella direzione opposta. Questo aiuta la pedalata, lo smorzamento delle vibrazioni e offre sostegno sugli impatti duri. La suola in gomma Afton's Intact™ Rubber è progettata per accettare pedali flat.

Taglie dal 7 al 13.

COLORI

Grey/Red, Black/Blue.



Vectal

€
119,99

SPECIFICHE

Scarpa in nylon e nabuk, interno in materiale tecnico. La progettazione ha puntato nell'ottenere comfort anche in una scarpa con gli attacchi pedale. È flessibile alla punta e al tallone quando si cammina ma rimane rigida nella pedalata. La regolabilità delle tacchette è di 35mm e consente una regolazione adatta a tutte le discipline.

Taglie dal 7 al 13.

COLORI

Black/Red, Black/Turquoise.



ALPINESTARS



★dsb★

SEMPLICEMENTE BICI

Drop Pro LS Jersey

SPECIFICHE

Maglia Enduro manica lunga.
Taglie S, M, L, XL, XXL.

CODICE

176 6518

13
Black Red



7097
Poseidon Blue
Atoll Blue



1047
Black
Acid Yellow



7096
Poseidon Blue
Summer Green



€
79,95

Drop Pro SS Jersey

SPECIFICHE

Maglia Enduro manica corta.
Taglie S, M, L, XL, XXL.

CODICE

176 6718

13
Black Red



1047
Black
Acid Yellow



7096
Poseidon Blue
Summer Green



7097
Poseidon Blue
Atoll Blue



€
69,95

Drop Pro Shorts

SPECIFICHE

Pantaloncini Enduro.
Taglie 28, 30,
32, 34, 36,
38, 40.

CODICE

172 6718

7097
Poseidon Blue
Atoll Blue



13
Black Red



1061
Black Acid
Yellow



7096
Poseidon Blue
Summer Green



€
129,95

Drop 2 Full Zip LS Jersey

SPECIFICHE

Maglia manica lunga
con cerniera lampo.
Taglie S, M, L, XL, XXL.

CODICE

176 6817

12
Black White



547
Acid Yellow
Black



€
74,95

Predator LS Jersey

SPECIFICHE

Maglia All Mountain manica lunga.
Taglie S, M, L, XL, XXL.

CODICE

176 6118

332
Red Cherry
White



1103
Black Steel
Gray Red



7044
Bright Blue
Poseidon Orange



1750
Black Royal Blue
Acid Yellow



€
54,95

Predator SS Jersey

SPECIFICHE

Maglia All Mountain manica corta.
Taglie S, M, L, XL, XXL.

CODICE

176 6018

1103
Black Steel
Gray Red



7044
Bright Blue
Poseidon Orange



1750
Black Royal Blue
Acid Yellow



332
Red Cherry
White



€
49,95

Predator Shorts

SPECIFICHE

Pantaloncini All Mountain.
Taglie 28, 30, 32, 34,
36, 38, 40.

CODICE

172 6016

561
Acid Yellow
Royal Blue



47
Bright Orange
Bright Blue



13
Black Red



10
Black



€
99,95

Crest 3/4 Sleeve Jersey

SPECIFICHE

Maglia All Mountain manica 3/4.
Taglie S, M, L, XL, XXL.

CODICE

176 1617

7094
Poseidon Blue
Energy Orange



7097
poseidon blue
atoll blue



3063
Rio Red
Alpinestars Red



€
57,95

Mesa LS Jersey

SPECIFICHE

Maglia All Mountain manica lunga.
Taglie S, M, L, XL, XXL.

CODICE
176 2616

4070
Energy Orange
Poseidon Blue



367
Red
Steel Gray



566
Acid Yellow
Summer Green



1047
Black
Acid Yellow



7039
Royal Blue
Bright Blue

€
59,95

Mesa SS Jersey

SPECIFICHE

Maglia All Mountain manica corta.
Taglie S, M, L, XL, XXL.

CODICE
176 2517

566
Acid Yellow
Summer Green



367
Red
Steel Gray



4070
Energy Orange
Poseidon Blue



1047
Black
Acid Yellow



7039
Royal Blue
Bright Blue

€
49,95

Mesa Shorts

SPECIFICHE

Pantaloncini All Mountain.
Taglie 28, 30, 32, 34,
36, 38, 40.

CODICE
172 2618



1065
Black
Dark Shadow

7095
Poseidon Blue
Acid Yellow

13
Black Red

4070
Energy Orange
Poseidon Blue



€
69,95

Elite SS Jersey

SPECIFICHE

Maglia Trail /XC manica corta.
Taglie S, M, L, XL, XXL.

CODICE
176 3317

7092
Poseidon Blue
White



32
Red White



13
Black Red



9025
Dark Shadow
Acid Yellow



€
44,95

Trailstar SS Jersey

SPECIFICHE

Maglia Trail /XC manica corta.
Taglie S, M, L, XL, XXL.

CODICE
176 4516

7096
Poseidon Blue
Summer Green



611
Bright Green
Black



13
Black Red



547
Acid Yellow
Black



€
49,95

Rover 2 Shorts

SPECIFICHE

Pantaloncini Trail /XC.
Taglie 28, 30, 32, 34,
36, 38, 40.

CODICE
172 4317

7092
Poseidon Blue
White



1065
Black
Dark Shadow



9021
Dark Shadow
Black



€
59,95

XC SS Jersey

SPECIFICHE

Maglia Trail /XC
manica corta.
Taglie S, M,
L, XL, XXL.

CODICE
176 0318

31
Red Black



13
Black Red



547
Acid Yellow
Black



€
74,95

Hyperlight 2 Shorts

SPECIFICHE

Pantaloncini
Trail /XC.
Taglie 28, 30,
32, 34,
36, 38, 40.

CODICE
172 6515

32
Red Black



10
Black



067
Steel Gray



€
79,95

Marathon Bib Shorts

SPECIFICHE
Salopette Trail / XC.
Taglie S, M, L, XL, XXL.
CODICE
172 1917

10
Black



€
94,95

Vetta Bib Shorts

SPECIFICHE
Salopette Trail / XC.
Taglie S, M, L, XL, XXL.
CODICE
172 1717

10
Black



€
114,95

Spokes Tee

SPECIFICHE
T-shirt tecnica.
Taglie S, M, L, XL, XXL.
CODICE
110 3517

7090
Poseidon
Blue



9029
Dark Shadow



10
Black

Blaze 2 Tee

SPECIFICHE
T-shirt tecnica.
Taglie S, M, L, XL, XXL.
CODICE
110 1015

9024
Dark Shadow
Bright Orange



32
Red White

7095
Poseidon Blue
Acid Yellow



1047
Black
Acid Yellow

€
37,95

Ageless Tech Tee

SPECIFICHE
T-shirt tecnica.
Taglie S, M, L, XL, XXL.
CODICE
110 0018

942
Melange
Steel Gray
White



1104
Black
Energy Orange



7097
Poseidon Blue
Atoll Blue

€
37,95

Racer LS Jersey

SPECIFICHE
Maglia Gravity / BMX
manica lunga.
Taglie S, M, L,
XL, XXL.
CODICE
176 7518

31
Red Black



7075
Petrol Yellow
Fluo



7119
Atoll Blue
Poseidon Blue



4070
Energy Orange
Poseidon Blue



€
64,95

Racer SS Jersey

SPECIFICHE
Maglia Gravity / BMX
manica corta.
Taglie S, M, L,
XL, XXL.
CODICE
176 7318

4070
Energy Orange
Poseidon Blue



31
Red Black



7075
Petrol Yellow
Fluo



7119
Atoll Blue
Poseidon Blue



€
59,95

Vector Pants

SPECIFICHE
Pantaloni Gravity / BMX.
Taglie 28, 30, 32, 34,
36, 38, 40.
CODICE
172 0917

1047
Black
Acid Yellow



13
Black Red



12
Black White



1104
Black
Energy Orange



1117
Black
Atoll Blue



€
119,95

Vector Shorts

SPECIFICHE
Pantaloncini
Gravity / BMX.
Taglie 28, 30, 32,
34, 36, 38, 40.
CODICE
172 1117

1047
Black
Acid Yellow



13
Black Red



12
Black White



1104
Black
Energy Orange



1117
Black
Atoll Blue



€
89,95

Youth Racer LS Jersey

SPECIFICHE

Maglia ragazzo manica lunga.

Taglie S, M, L, XL.

CODICE
177 7518



31
Red Black

7075
Petrol Yellow
Fluo



7119
Atoll Blue
Poseidon Blue



4070
Energy Orange
Poseidon Blue



€
29,95

Youth Vector Pants

SPECIFICHE

Pantaloni ragazzo.

Taglie 22, 24, 26, 28.

CODICE
174 0917



1047
Black
Acid Yellow

€
99,95



12
Black White



1104
Black
Energy Orange



1117
Black
Atoll Blue

Youth Vector Shorts

SPECIFICHE

Pantaloncini ragazzo.

Taglie 22, 24, 26, 28.

CODICE
174 0818



1047
Black
Acid Yellow

€
69,95



12
Black White



1104
Black
Energy Orange



1117
Black
Atoll Blue

Youth F-Lite Glove

SPECIFICHE

Guanti ragazzo.

Taglie XXXS, XXS, XS, S, M, L.

CODICE
154 6817



1061
Black
Steel Gray

€
27,95



32
Red White



547
Acid Yellow
Black

Youth Neck Support

SPECIFICHE

Supporto protettivo per il collo ragazzo.

Taglia unica.

CODICE
654 0118



155
Black Yellow Fluo

€
119,95

Sequence Youth Neck Roll

SPECIFICHE

Supporto protettivo per il collo ragazzo.

Taglie S/M, L/XL.

CODICE
674 1018



13
Black Red

€
39,95

Youth Bionic Action Jacket

SPECIFICHE

Giacca protettiva ragazzo.

CODICE
654 6818



13
Black Red

€
129,95



Youth Vapor Pro Knee Protector

€ 44,95

SPECIFICHE
Protezioni ginocchia ragazzo.
Taglia unica.
CODICE
654 2316



106
Black Gray

Youth Vapor Pro Elbow Protector

€ 44,95

SPECIFICHE
Protezioni gomiti ragazzo.
Taglia unica.
CODICE
654 2216



106
Black Gray

Stella Drop 2 LS Jersey

€ 64,95

SPECIFICHE
Maglia da donna manica lunga.
Taglie XS, S, M, L, XL.
CODICE
178 6417



48
Bright Orange Ocean



7002
Ocean White



1038
Black Plum

Stella Drop 2 SS Jersey

€ 59,95

SPECIFICHE
Maglia da donna manica corta.
Taglie XS, S, M, L, XL.
CODICE
178 6317



1038
Black Plum



7002
Ocean White



48
Bright Orange Ocean

Stella Drop 2 Shorts

€ 129,95

SPECIFICHE
Pantaloncini da donna.
Taglie 26, 28, 30, 32, 34.
COLORI
173 6317



7003
Ocean Bright Orange



1070
Black Ocean



1038
Black Plum



Stella Mesa SS Jersey

€ 49,95

SPECIFICHE
Maglia da donna manica corta.
Taglie XS, S, M, L, XL.
CODICE
178 2516



7007
Blue Acqua



1035
Black Raspberry Rose



5025
Acid Yellow Dark Shadow

Stella Pathfinder Shorts

€ 119,95

SPECIFICHE
Pantaloncini da donna.
Taglie 26, 28, 30, 32, 34.
COLORI
173 5016



7007
Blue Acqua



1035
Black Raspberry Rose



9025
Dark Shadow Acid Yellow



Stella F-Lite Glove

€ 29,95

SPECIFICHE
Guanto donna.
CODICE
158 6816



7001
Ocean Black



1035
Black Raspberry Rose

Descender 2 Jacket

SPECIFICHE
Giacca antivento.
Taglie S, M, L,
XL, XXL.
CODICE
122 0516



7097
Poseidon Blue
Atoll Blue



1047 Black Acid Yellow
547 Acid Yellow Black
3063 Rio Red Alpinestars Red
10 Black

€
99,95

Descender 2 Vest

SPECIFICHE
Gilet antivento.
Taglie S, M, L,
XL, XXL.
CODICE
165 0517



1047
Black Acid Yellow

€
89,95



547
Acid Yellow
Black

Kicker Pack Jacket

SPECIFICHE
Giacca antivento.
Taglie S, M, L,
XL, XXL.
CODICE
132 2717



7110
Atoll Blue



10 Black
55 Yellow Fluo

€
79,95

Outrider Wr Base Shorts

SPECIFICHE
Pantaloncini.
Taglie 28, 30,
32, 34, 36,
38, 40.
COLORI
172 5916



10
Black



9020 Dark Shadow White
1033 Black Rio Red

€
114,95

Linestorm Glove

SPECIFICHE
Guanti.
Taglie S, M, L, XL,
XXL, XXXL.
CODICE
156 1318



7095
Poseidon Blue
Acid Yellow



32 Red White
547 Acid Yellow Black
13 Black Red

€
44,95

Drop Pro Glove

SPECIFICHE
Guanti.
Taglie S, M, L,
XL, XXL, XXXL.
CODICE
156 6518



31
Red Black



2047 White Acid Yellow
7094 Poseidon Blue Energy Orange
067 Steel Gray

€
49,95

Stratus Glove

SPECIFICHE
Guanti.
Taglie S, M,
L, XL, XXL,
XXXL.
CODICE
156 8013



13
Black Red



7048 Deep Blue Acid Yellow
547 Acid Yellow Black
441 Burnt Orange Black
1061 Black Steel Gray

€
39,95

Aero V3 Glove

SPECIFICHE
Guanti.
Taglie S, M,
L, XL, XXL,
XXXL.
CODICE
156 3218



367
Red Steel Gray



1061 Black Steel Gray
16 Black Green
7094 Poseidon Blue Energy Orange
7097 Poseidon Blue Atoll Blue

€
32,95

F-Lite Glove

SPECIFICHE

Guanti.
Taglie S, M, L,
XL, XXL, XXXL.

CODICE

156 6815



€
29,95

Predator Glove

SPECIFICHE

Guanti.
Taglie S, M,
L, XL, XXL,
XXXL.

CODICE

156 4518



€
26,95

Racer Glove

SPECIFICHE

Guanti.
Taglie S, M, L, XL,
XXL, XXXL.

CODICE

156 7318



€
26,95

Rolling Short Finger Glove

SPECIFICHE

Guanti dita corte.
Taglie S, M, L, XL,
XXL, XXXL.

CODICE

156 7118



€
29,95

Cirrus Glove

SPECIFICHE

Guanti.
Taglie S, M, L, XL,
XXL, XXXL.

CODICE

152 0717



€
22,95

Tech Top Winter Long Sleeve

SPECIFICHE

Maglia termica invernale
manica lunga.

Taglie XS/S, M/L, XL/2XL.

CODICE

175 0017



€
89,95

Tech Top Long Sleeve

SPECIFICHE

Maglia termica
manica lunga.

Taglie XS/S, M/L,
XL/2XL.

CODICE

175 0217

198 Silver
Red



€
69,95

Tech Top Short Sleeve

SPECIFICHE

Maglia termica
manica corta.

Taglie XS/S, M/L,
XL/2XL.

CODICE

175 1017

13 Black
Red



€
59,95

Tech Tank

SPECIFICHE
Maglia termica
senza maniche.
Taglie XS/S, M/L,
XL/2XL.
CODICE
175 2017

13
Black Red



€
49,95



198
Silver Red

Tech Shorts

SPECIFICHE
Sottopantaloncini.
Taglie XS/S, M/L,
XL/2XL.
CODICE
175 3017

13
Black Red



€
69,95

Inner Shorts Pro

SPECIFICHE
Sottopantaloncini.
Taglie XXS, XS, S,
M, L, XL.
CODICE
171 1517

10
Black



€
44,95

Inner Shorts

SPECIFICHE
Sottopantaloncini.
Taglie XXS, XS, S,
M, L, XL.
CODICE
171 1017

10
Black



€
34,95

Compression Socks

SPECIFICHE
Calzini.
Taglie S, M, L.
CODICE
170 0016

13
Black Red

7037
Royal Blue Black

41
Orange Black

201
White Gray



€
21,95

Thermal Crew Socks

SPECIFICHE
Calzini.
Taglie S, M, L.
CODICE
170 1516

13
Black Red

1037
Black Royal Blue



€
19,95

Crew Socks

SPECIFICHE
Calzini.
Taglie S, M, L.
CODICE
170 1816

13
Black Red

1047
Black
Acid Yellow

1062
Black
Bright Green

1037
Black
Royal Blue



€
14,95

Winter Socks

SPECIFICHE
Calzini.
Taglie S/M, L/XL.
CODICE
1701014

547
Acid Yellow
Black

13
Black
Red

107
Gray
Black

106
Black
Gray

7117
Atoll Blue
Black



€
12,95

Summer Socks

SPECIFICHE
Calzini.
Taglie S/M, L/XL.
CODICE
170 1114



€
10,95

Star Socks

SPECIFICHE
Calzini.
Pacco da 6 paia.
Taglie S/M, L/XXL.
CODICE
470 608



€
49,95

Low Riding Socks

SPECIFICHE
Calzini.
Taglie S/M, L/XXL.
CODICE
170 1012



€
7,95

BNS Tech Carbon Neck Support

SPECIFICHE
Supporto
protettivo
per il collo,
peso 735g.
Taglie XS/M
L/XL.
CODICE
650 0014



€
349,95

BNS Pro Neck Support

SPECIFICHE
Supporto
protettivo
per il collo,
peso 810g.
Taglie XS/M
L/XL.
CODICE
650 0114



€
249,95

Attachment Plate for BNS Tech Carbon

SPECIFICHE
Staffe di ricambio
per BNS Neck Support.
CODICE
695 0014 10



€
29,95

Chin Plate for BNS Tech Carbon

SPECIFICHE
Placche anteriori di ricambio
per BNS Neck Support.
CODICE
695 1014 312



€
16,95

Soft Insert Pad Set for BNS (6 and 10mm)

SPECIFICHE
Set di imbottiture
morbide per BNS Neck Support.
CODICE
695 1214 10



€
19,95

X-Straps for BNS

SPECIFICHE
Cinghie di ricambio
per BNS Neck Support.
CODICE
695 0214 10



€
9,95

Size Adapter Kit for BNS XS/M-L/XL

SPECIFICHE
Adattatori di taglia
per BNS Neck Support.
CODICE
695 1314 10



€
44,95

BNS Closure System

SPECIFICHE
Sistema di chiusura
per BNS Neck Support.
CODICE
695 1414 12



€
34,95

Bionic Action Jacket

SPECIFICHE
Giacca protettiva.
Taglie S, M, L, XL, 2XL.
CODICE
165 6818



13
Black Red

€
149,95

Sequence Pro Shorts

SPECIFICHE
Sottopantaloncini
protettivi.
Taglie S, M, L,
XL, 2XL.
CODICE
165 7818



13
Black Red

€
89,95

Sequence Elbow Protector

SPECIFICHE
Protezioni gomiti.
Taglie S-M, L-XL, 2XL.
CODICE
165 3018



13
Black Red

€
64,95

Sequence Knee/Shin Protector

SPECIFICHE
Protezioni ginocchia.
Taglie S-M, L-XL, 2XL.
CODICE
165 3218



13
Black Red

€
114,95

Evolution LS Jacket

SPECIFICHE
Giacca protettiva
maniche lunghe
removibili.
Taglie XS, S, M,
L, XL, XXL.
CODICE
165 6717

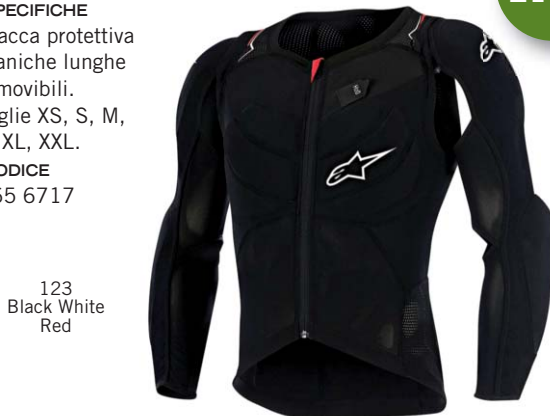

123
Black White
Red

€
219,95

Evolution Jacket

SPECIFICHE
Giacca protettiva
maniche corte.
Taglie XS, S, M,
L, XL, XXL.
CODICE
165 6515



123
Black White
Red

€
189,95

Evolution Vest

SPECIFICHE
Gilet protettivo.
Taglie XS, S, M,
L, XL, XXL.
CODICE
165 8717



123
Black White
Red

€
169,95

Evolution Shorts

SPECIFICHE
Sottopantaloncini
protettivi.
Taglie XS, S, M,
L, XL, XXL.
CODICE
165 7515



123
Black White
Red

€
89,95

Evolution Knee/Shin Protector

€ 109,95

SPECIFICHE
Protezioni ginocchia.
Taglie S-M, L-XL.
CODICE
165 0718



123
Black White
Red

Evolution Knee Protector

€ 79,95

SPECIFICHE
Protezioni ginocchia.
Taglie S-M, L-XL.
CODICE
165 0618



123
Black White
Red

Evolution Elbow Protector

€ 69,95

SPECIFICHE
Protezioni gomiti.
Taglie S-M, L-XL.
CODICE
165 0518



123
Black White
Red

Paragon Vest

€ 114,95

SPECIFICHE
Gilet protettivo.
Taglie S, M,
L, XL, XXL.
CODICE
165 8816



15
Black Yellow

Paragon Bib Shorts

€ 234,95

SPECIFICHE
Salopet
pantaloni corti.
Taglie S, M,
L, XL, XXL.
CODICE
172 2417



10
Black

Paragon Knee Protector

€ 49,95

SPECIFICHE
Protezioni ginocchia.
Taglie 2XS, XS, S,
M, L, XL, XXL.
CODICE
165 2414



1062
Black
Bright
Green

13
Black
Red

10
Black

15
Black Yellow

Paragon Elbow Protector

€ 42,95

SPECIFICHE
Protezioni gomiti.
Taglie 2XS, XS, S,
M, L, XL, XXL.
CODICE
165 2514



1062
Black
Bright
Green

13
Black
Red

10
Black

Paragon Knee/Shin Protector

€ 69,95

SPECIFICHE
Protezioni stinchi
e ginocchia
Taglie XS, S, M,
L, XL, XXL.
CODICE
165 2618



1047
Black
Acid Yellow

E-Ride Knee Protector

€ 84,95

SPECIFICHE
Protezioni
ginocchia.
Taglie S/M, L/XL.
CODICE
165 1118



1079
Black Cyan

E-Ride Elbow Protector

€ 89,95

SPECIFICHE
Protezioni gomiti.
Taglie S/M, L/XL.
CODICE
165 1018



1079
Black Cyan

BRAKE AUTHORITY

BRAKE
AUTHORITY.



★dsb★

SEMPLICEMENTE BICI

Burly

€ 16,00

SPECIFICHE

Pastiglie per freno a disco sinterizzate ad alte prestazioni per XC / AM / Enduro. Lunga durata.



BA4050	AVID BB5	
BA4045	AVID CODE	
BA4054	AVID CODE 2011	
BA4060	AVID XO TRAIL	
BA4051	AVID ELIXIR	
BA4023	AVID SYSTEM 975	
BA4035	AVID SYSTEM JUICY 3,5,7 HYDRAULIC ULTIMATE & MECHANICAL BB7 & SYS. 975	
BA4008	DIATECH KINETIC NIFON MECHANICAL	
BA4019	FORMULA B4	
BA4044	HOPE TECH V2	
BA4049	HOPE X2	
BA4058	HOPE TECH V4	
BA4059	HOPE TECH E2	
BA4017	MAGURA CLARA 2001/2002 LOUISE 2002/2003	
BA4010	MAGURA GUSTAV	
BA4018	MAGURA JULIE	
BA4003	MAGURA LOUISE CLARA 2000	

Aggressive

€ 24,90

SPECIFICHE

Pastiglie per freno a disco sinterizzate ad alte prestazioni per FR / DH. Alte prestazioni in condizioni difficili.



BA4001	FORMULA EVOLUTION HYDRAULIC	
BA4041	FORMULA ORO	
BA4046	FORMULA THE ONE, MEGA, R1, RX	
BA4026	GIANT MPH 2000	
BA4028	GIANT MPH 2001/2005 MPH2, MPH3	
BA4005	GRIMECA 7	
BA4037	HAYES EL CAMINO HYDRAULIC	
BA4057	HAYES PRIME	
BA4036	HAYES SOLE GX-2 MX-2 MX-3	
BA4027	MAGURA MARTA 2005/2008	
BA4042	MAGURA MARTA 2009 LOUISE 2007 / JULIE	
BA4062	MAGURA MT7 2 paires par étrier <small>Burly 30€ Aggressive 34€ A.Ceramic 38€</small>	
BA4056	MAGURA MTS MT2 MT4 MT6 MT8	
BA4024	PROMAX/HAYES HYDRAULIC HAYES MECHANICAL MX-1 MAG HFX-9	
BA4039	PROMAX DSK700	
BA4009	RST MECHANICAL	
BA4021	SHIMANO DEORE BR-M515 BR-M525 MECA 01, HYDRO 03-04 TEKTRU AURIGA GIANT ROUTE	

Ceramic

€ 29,90

SPECIFICHE

Pastiglie per freno a disco specifiche race, ideale per tutti gli usi. Adatta nelle gare. Alta resistenza al fading.



BA4053	HAYES STROKER ACE	
BA4047	HAYES STROKER RYDE	
BA4048	HAYES STROKER TRAIL GRAM	
BA4015	HOPE 2 PISTONS	
BA4011	HOPE 4 PISTONS 2 paires par étrier	
BA4012	HOPE 4 PISTONS XC4	
BA4030	HOPE 6 PISTONS MONO 6T	
BA4032	HOPE MONO MINI	
BA4022	HOPE MINI 2 PISTONS 2001	
BA4020	SHIMANO DEORE HYDRAULIC BR-555 2011-2002	
BA4052	SHIMANO SAINT 08	
BA4004	SHIMANO XT GRIMECA 8,16 CLEG DH SRAM HOPE MONO4, NEW M4 2009	
BA4031	SHIMANO XTR 2003-2007 SAINT 2004-2007, LX2005-2007 XT 2004-2007, SLX 2009	
BA4055	SHIMANO XTR 2011, SLX, XT2012	
BA4025	TEKTRU GEMINI JUSQU'À 2003	
BA4033	TEKTRU GEMINI DEPUIS 2003	



HIPILOK

HIPILOK



★dsb★

SEMPLICEMENTE BICI

Z-Lok

SPECIFICHE

Fascetta in plastica con anima in acciaio.
Lunghezza 40cm.
Chiave universale.

COLORI

Dark Grey, Lime, Red.



€
19,90

A coppia

Pop

SPECIFICHE

Lucchetto a cavo indossabile.
Lunghezza 1,3m.

COLORI

Nero, Blu, Giallo, Rosa.



€
29,90

Fx

SPECIFICHE

Lucchetto riavvolgibile.
Lunghezza 1m, riflettente.
Ideale per ruote e piccoli oggetti.

COLORI

Blu, Giallo, Rosso.

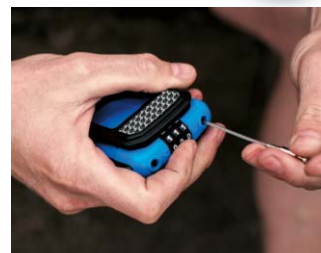

€
29,90

Lite

SPECIFICHE

Catena da 6mm indossabile.
Lunghezza 75cm.

COLORI

Giallo, Rosa, Blu, Bianco,
Nero, Camo, Riflettente.



€
64,90

€
69,90

Riflettente



V1,50 Original

SPECIFICHE

Da dove sono nati. Catena 8mm in acciaio indossabile.
Lunghezza 85cm,

COLORI

Nero, Camo, Riflettente.



€
89,90

€
99,90

Riflettente



Gold

SPECIFICHE

Catena in acciaio indossabile 10mm.
Lunghezza 85cm.

COLORI

Nero, Camo/Arancio, Riflettente.



€
119,90

€
129,90

Riflettente



Homie

SPECIFICHE

Catena da 10mm. utilizzo casalingo. Massima sicurezza.
Lunghezza 150cm.

COLORI

Nero.



€
149,90

D / DC

SPECIFICHE

Lucchetto a D. Tubo 13mm. Spazio interno 13,5x7 cm.

COLORI

Nero, Giallo.



€ 69,90

€ 79,90

DC
con cavo da 1m

DX / DXC

SPECIFICHE

Lucchetto a D. Tubo 14mm. Spazio interno 15x8,5cm.

COLORI

Nero, Arancio,
Rosso.



€ 82,90

€ 89,90

DXC
con cavo da 1m

Airlok

SPECIFICHE

Sistema di lucchetto a parete. Massima sicurezza.

COLORI

Rosso, Grigio, Bianco.



€ 179,90



HOPE

hope



★dsb★

SEMPLICEMENTE BICI

Tech3 V4 Braided

€
239,90

SPECIFICHE

Freno a disco a 4 pistoncini per DH/FR.
Con guaina Goodgrige.

COLORI

Black, Red, Orange, Silver, Purple, Blue.



Tech3 V4 Black Hose

€
229,90

SPECIFICHE

Freno a disco a 4 pistoncini per DH/FR.

COLORI

Black, Red, Orange, Silver, Purple, Blue.



Tech3 E4 Braided

€
224,90

SPECIFICHE

Freno a disco a 4 pistoncini ideale per FR/AM.
Con guaina Goodgrige.

COLORI

Black, Red, Orange, Silver, Purple, Blue.



Tech3 E4 Black Hose

€
214,90

SPECIFICHE

Freno a disco a 4 pistoncini ideale per FR/AM.

COLORI

Black, Red, Orange, Silver, Purple, Blue.



Tech3 X2 Braided

€
189,90

SPECIFICHE

Freno a disco a 2 pistoncini per XC/Trail/AM.
Con guaina Goodgrige.

COLORI

Black, Red, Orange, Silver, Purple, Blue.



Tech3 X2 Black Hose

€
179,90

SPECIFICHE

Freno a disco a 2 pistoncini per XC/Trail/AM.

COLORI

Black, Red, Orange, Silver, Purple, Blue.



Race EVO X2 Black Hose

€
219,90

SPECIFICHE

Freno a disco a 2 pistoncini per XC, viti in titanio.

COLORI

Black.



Race EVO M4 Black Hose

€
239,90

SPECIFICHE

Freno a disco a 4 pistoncini per AM, viti in titanio.

COLORI

Black.



Trial Zone

€
199,90

SPECIFICHE

Freno a disco a 2 pistoncini.

COLORI

Black.

Tech3 Trial

€
214,90

SPECIFICHE

Freno a disco a 2 pistoncini, leva Tech.

COLORI

Black.

V-TWIN

€
399,00

SPECIFICHE

Per trasformare la bici ciclocors/corsa in disco, 2x2 pinze.

COLORI

Black.

RX4 Caliper Flat Mount

€
119,90

SPECIFICHE

Pinza per bici da corsa. Specificare se Shimano o Sram.

COLORI

Black, Red, Orange, Silver, Purple, Blue.

RX4 Caliper Post Mount

€
99,90

SPECIFICHE

Pinza per bici da corsa. Specificare se Shimano o Sram.

COLORI

Black, Red, Orange, Silver, Purple, Blue.

Dischi flott. road 160mm

€
59,90

SPECIFICHE

Disco flottante road Ø 160mm.

Dischi fissi

€
41,90

SPECIFICHE

Disco fisso.

fino 183 mm

€
47,90

oltre 183 mm

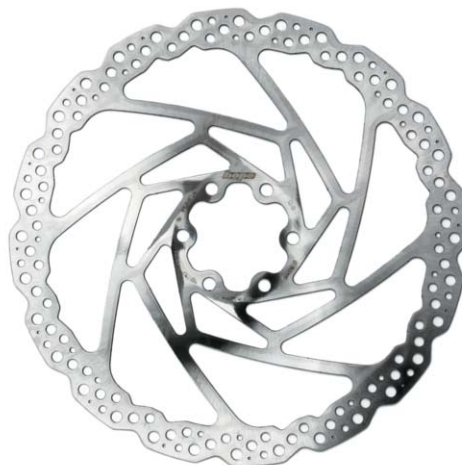

Dischi flottanti

€
54,90

SPECIFICHE

Disco flottante.

COLORI

Black, Red, Orange, Silver, Purple, Blue.

fino 183 mm

€
64,90

oltre 183 mm



Dischi ventilati

SPECIFICHE

Disco ventilato Ø 203mm. Peso 288gr.

COLORI

Black, Red, Orange, Silver, Purple, Blue.



€
139,90

Adattatori disco

SPECIFICHE

Adattatori PM e IS. Ampia scelta di misure.

- H Postmount 160 > Postmount 183 mm
Postmount 180 > Postmount 203 mm
- K Postmount 140 > Postmount 160 mm
Postmount 180 > Postmount 200 mm
- F IS Front > Postmount 180 mm
IS Rear > Postmount 160 mm
- C Postmount 160 > Postmount 203 mm
- B IS Front 160mm > Postmount 203 mm
IS Rear 160 mm > Postmount 183 mm
- A IS Front > Postmount 160 mm
IS Rear > Postmount 140 mm
- J IS Front 160 mm > Postmount 183 mm
- G IS Rear 160 mm > Postmount 203 mm
- E Fox40 > Postmount 203 mm
Pre 2014 forks only
- D Booxer > Postmount 203 mm
Pre 2009 forks only

COLORI

Black, Silver.

€
21,90

Pro 4 Front

SPECIFICHE

Mozzo anteriore per disco 15mm.

Anche QR, 20mm e Boost.

COLORI

Black, Red, Orange, Silver,
Purple, Blue.



€
89,90

Pro 4 Rear

SPECIFICHE

Mozzo posteriore 135-142-148 sia Sram che Shimano.

QR - 10 - 12mm

COLORI

Black, Red, Orange, Silver, Purple, Blue.

€
219,90



Pro 4 Rear DH 7sp

SPECIFICHE

135-142-150-157

COLORI

Black, Red, Orange, Silver,
Purple, Blue.



€
239,90

Pro 4 Rear SingleSpeed

SPECIFICHE

Anche per trial.

COLORI

Black, Red, Orange, Silver, Purple, Blue.

€
239,90



Pastiglie freni standard

€
19,90

Pastiglie freni sinterizzate

€
24,90

Pro 4 Rear 150mm

SPECIFICHE

150mm, Peso 314g.

COLORI

Black, Red, Orange, Silver, Purple, Blue.

€
239,90



Pro 4 Fatsno Front

SPECIFICHE

Battuta 135, 15mm e QR - su ordinazione.

COLORI

Black, Red, Orange, Silver, Purple, Blue.

€
109,90



Pro 4 Fatsno Rear

SPECIFICHE

Battuta 170-177-190-197.

COLORI

Black, Red, Orange, Silver, Purple, Blue.

€
249,00



Conversion Kit Pro 2 ant.

SPECIFICHE

Kit per trasformare un Pro 2 front in 15mm o 20mm.

€
24,90

Conversion Kit Pro 2 post.

SPECIFICHE

Da 135 a 142 oppure da 150 a 157mm.

€
19,90

Ruote Enduro

SPECIFICHE

27,5 e 29 - 110 148

COLORI

Black, Red, Orange,
Silver, Purple,
Blue.

€
499,00



Cassetta 11 SPD 10-44T

SPECIFICHE

Black inclusa la ruota libera Hope.

€
279,90



Guarnitura

€
349,00

SPECIFICHE

Disponibile da 165, 170 e 175mm. Assale da 30 mm oversized. Peso 641g. Senza corona.

COLORI

Black, Silver, Red, Purple, Blu.



Shifter mount

€
34,90

SPECIFICHE

Mantiene il manubrio ordinato.

Disponibile per leva Race, Tech e Tech3.

COLORI

Black, Silver.



€
18,90

singolo

Pedale Flat F20

€
169,90

SPECIFICHE

Tutto CNC - 20 PINS - 3 cuscinetti + tenuta Norglide.

Peso 390g.

COLORI

Black, Red, Orange, Silver, Purple, Blue.



Attacco manubrio

€
114,90

SPECIFICHE

AM 35mm std o 35 e 50mm OS 35

COLORI

Black, Silver, Red, Blue, Purple, Orange.



Attacco manubrio

€
114,90

SPECIFICHE

DH 50mm.

COLORI

Black, Red, Blue, Purple, Orange.



Attacco manubrio

€
134,90

SPECIFICHE

Direct Mount 40-50mm.

COLORI

Black, Red, Blue, Purple, Orange.



Attacco manubrio

SPECIFICHE

Top Crown - Fox 40 e Boxxer.

COLORI

Black, Silver, Red, Blue, Purple, Orange.

€
249,00



Carbon handlebar

SPECIFICHE

Piega in carbonio 780mm - alt. 20mm.

€
199,90



Carbon seatpost

SPECIFICHE

Reggisella in carbonio 27,2 - 30,9 - 31,6.

€
169,90



Manopole

SPECIFICHE

Manopole.

COLORI

Verde, Rosso,
Bianco, Nero.

€
31,90



Serie sterzo

SPECIFICHE

Da 1 1/8 - 1,5 - Step Down.

€
119,90



Movimento Centrale

SPECIFICHE

Movimento centrale esterno su cuscinetti in acciaio INA.
Road/68-73-DH83.

€
119,90



Movimento Centrale

SPECIFICHE

Movimento centrale esterno su cuscinetti in acciaio INA.
Press Fit 30 e 41.

€
129,90

IBR Integrated Bash Ring

SPECIFICHE

Corona e bash integrati per singola, 32-33-34-35-36 denti.

COLORI

Black - Gold.

€
99,90

Bash Guard

SPECIFICHE

Paracorona.

COLORI

Black, Silver, Blue, Red, Purple, Orange.



€
54,90

QR Steel

SPECIFICHE

Chiusure ruote in acciaio 115g.

COLORI

Black, Silver, Red, Blue, Purple, Orange.



€
47,90

Coppia

€
24,90

Solo post.

T-REX

SPECIFICHE

Pignone 40 denti x Sram e Shimano.

COLORI

Oro, Nero, Silver.

€
79,90

Slick Guide Top only

SPECIFICHE

Guidacatena superiore.

€
69,90

QR Seat clamp

SPECIFICHE

Chiusura sella Ø 31,8 - 34,9 - 36,4mm

COLORI

Black, Silver, Red, Blue, Purple, Orange.



€
29,90

€
24,90

No leva

Space Doctor

SPECIFICHE

Confezione spessori 5-10-20mm.

COLORI

Black, Silver, Red, Blue, Purple, Orange.

€
12,90

Hed Doctor

SPECIFICHE

Tappo per headset. Per risolvere i continui allentamenti.

€
23,90

Grip Doctor

SPECIFICHE

Tappi manopole CNC.

€
23,90

R8 LED Std

SPECIFICHE

4000 Lumens.

Due sequenze di potenza, ognuna con tre livelli di luce.



€
349,00

R4 LED Std

SPECIFICHE

2000 Lumens.



€
279,00

R2 LED Std

SPECIFICHE

2 Led, 1300 Lumens.



€
209,00

INDUSTRY NINE



INDUSTRY NINE
COMPONENTRY



★dsb★

SEMPLICEMENTE BICI

Ultralite 235

€
1.449,00

SPECIFICHE

Ruote per XC superleggere 26" 1.305g. - 27,5 1.390g. 29" 1.415g. Peso limite cliente 82kg. Anche per Lefty.

COLORI

Nero, Rosso, Silver.



Trail 245 24 raggi

€
1.449,00

SPECIFICHE

Ruote per Trail/AM 26"-1.420g. 27,5-1.485g. 29"-1.520g. Cerchio 23,4mm interno.

COLORI

Nero, Rosso, Silver.



Trail 245 32 raggi

€
1.449,00

SPECIFICHE

Ruote per Trail/AM da 32 raggi
26" 1.490g. - 27,5 1.555g. - 29" 1.630g.

COLORI

Nero, Rosso, Silver.



Enduro

€
1.449,00

SPECIFICHE

Ruote per Enduro/FR 26" 1.620g. - 27,5 1.680g. 29 1.780g. Cerchio da 26mm interno.

COLORI

Nero, Rosso, Silver.



Enduro 305

€
1.499,00

SPECIFICHE

Ruote per Enduro/FR 26" 1.620g. - 27,5 1.680g. 29" 1.780g. Cerchio da 30 interno 1.700g.

COLORI

Nero, Rosso, Silver.



Gravity

€
1.449,00

SPECIFICHE

Ruote per DH 26" 1.750g. - 27,5 1.840g. 29" 1.950g.

COLORI

Nero, Rosso, Silver.



Back Country 360

SPECIFICHE

Ruote per biciclette plus, canale da 36.

COLORI

Nero, Rosso, Silver.

€
1.499,00



Big Rig 845

SPECIFICHE

Ruote Fat solo da 26.

COLORI

Nero, Rosso, Silver.

€
1.549,00



Ultralite 24 Carbon

SPECIFICHE

Solo da 29" peso 1.350g. Peso limite cliente 88kg.

COLORI

Nero, Rosso, Silver.

€
2.799,00



Trail 24 Carbon

SPECIFICHE

Solo da 27,5 peso 1.390g. Peso limite cliente 110kg

COLORI

Nero, Rosso, Silver.

€
2.799,00



Trail Carbon

SPECIFICHE

Solo da 29" peso 1.500g. Peso limite cliente 100kg.

COLORI

Nero, Rosso, Silver.

€
2.799,00



Enduro Carbon

SPECIFICHE

Solo da 27,5 peso 1.520g. Peso limite cliente 110 kg.

COLORI

Nero, Rosso, Silver.

€
2.799,00



Enduro 310 Carbon

SPECIFICHE
Da 27,5 e 29".
COLORI
Nero, Rosso, Silver.

€
2.999,00

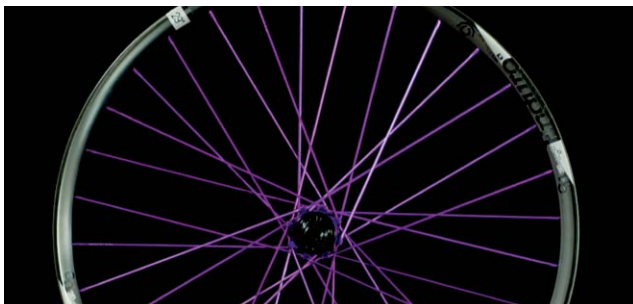

Big Rig Carbon 825

SPECIFICHE
Ruote Fat 26" e 27,5.
COLORI
Nero, Rosso, Silver.

€
3.299,00



Opzioni

Custom Level 1

SPECIFICHE
Qualsiasi combinazione di mozzi e raggi
Neri, Rossi, Silver.

€
55,00

Custom Level 3

SPECIFICHE
Doppio colore per ruote.

€
260,00

Custom Level 2

SPECIFICHE
Colori Blue, Oro, Verde, Rosa, Turchese, Arancio, Viola.

€
160,00

Mozzi (la coppia)



Mtb

SPECIFICHE
28 o 32 - QR/15/20/Lefty - 135/142/150 o SS.
COLORI
Nero, Blue, Oro, Verde, Verde chiaro, Arancio, Rosa, Viola, Rosso, Silver, Turchese.

€
699,00

Fat Bike

SPECIFICHE
32 - 15x135/15x142 - 170/177/190/197.
COLORI
Nero, Blue, Oro, Verde, Verde chiaro, Arancio, Rosa, Viola, Rosso, Silver, Turchese.

€
729,00

Road

SPECIFICHE
18/20/24/28/32 ant - 24/28/32 post.
24/28/32 - qr/15 - qr/142
COLORI
Nero, Blue, Oro, Verde, Verde chiaro, Arancio, Rosa, Viola, Rosso, Silver, Turchese.

€
679,00

Road Disc

SPECIFICHE
28 o 32 - QR/15/20/Lefty - 135/142/150 o SS.
COLORI
Nero, Blue, Oro, Verde, Verde chiaro, Arancio, Rosa, Viola, Rosso, Silver, Turchese.

€
699,00

LIZARD SKINS



★dsb★

SEMPLICEMENTE BICI

DSP Race Bar Tape 1,8

€
39,90

SPECIFICHE

Nastro manubrio per bici da corsa
1,8mm di spessore, peso 50g

COLORI

DSPDSE10 - Black
DSPDSE20 - White
DSPDSE40 - Blue
DSPDSE43 - Sky Blue
DSPDSE50 - Red
DSPDSE55 - Neon Pink
DSPDSE70 - Green
DSPDSE87 - Neon



DSP Bar Tape 1,8 Camo

€
44,90

SPECIFICHE

Nastro manubrio per bici da corsa colori Camo.
1,8mm di spessore, peso 50g.

COLORI

DSPDSE11 - Black Camo
DSPDSE27 - Yamasaki Camo
DSPDSE33 - Phantom Camo
DSPDSE59 - Wildfire Camo



DSP Bar Tape 2,5

€
39,90

SPECIFICHE

Nastro manubrio per bici da corsa in DuraSoft.
2,5mm di spessore, 56 grammi di peso tappi inclusi.
Lunghezza 208cm.

COLORI

DSPDS100 - Black
DSPDS200 - White
DSPDS400 - Blue
DSPDS430 - Sky Blue
DSPDS475 - Cobalt Blue
DSPDS500 - Red
DSPDS555 - Neon Pink
DSPDS600 - Brown
DSPDS700 - Green
DSPDS750 - Celeste Green
DSPDS800 - Yellow
DSPDS875 - Neon
DSPDS975 - Tangerine
DSPDS000 - Purple



DSP Bar Tape 2,5 Dual color

€
44,90

SPECIFICHE

Nastro manubrio per bici da corsa in DuraSoft doppio colore.
2,5mm di spessore, 56 grammi di peso tappi inclusi.
Lunghezza 208cm.

COLORI

DSPDSD12 - Black/White Dual
DSPDSD15 - Red/Black Dual
DSPDSD51 - Red/White Dual
DSPDSD81 - Neon/Black Dual
DSPDSD55 - Black/Neon Pink
DSPDSD49 - Cobalt Blue/Orange
DPSDSD48 - Cobalt Blue/Neon



DSPDS111 - Black Camo
DSPDS250 - Dynamite Camo
DSPDS270 - Yamasaki Camo
DSPDS303 - Phantom Camo
DSPDS404 - Blue Cam
DSPDS590 - Wildfire Camo
DPSDSD503 - Red Camo



DSP Comfort Bar Tape 3,2

€
44,90

SPECIFICHE

Nastro manubrio per bici da corsa.
3,2mm di spessore, 78g. di peso.
Lunghezza 226cm.

COLORI

DSPDST10 - Black
DSPDST20 - White
DSPDST40 - Blue
DSPDST43 - Sky Blue
DSPDST50 - Red
DSPDST55 - Neon Pink
DSPDST70 - Green
DSPDST87 - Neon



DSP Bar Tape 3,2 Camo

€
49,90

SPECIFICHE

Nastro manubrio per bici da corsa colori Camo.
3,2mm di spessore, 78g. di peso.
Lunghezza 226cm.

COLORI

DSPDST11 - Black Camo
DSPDST27 - Yamasaki Camo
DSPDST33 - Phantom Camo
DSPDST59 - Wildfire Camo



Small Neoprene

SPECIFICHE

Batticatena in Neoprene misura small.



CHSDS100 - Black



CHSDS400 - Blue



CHSDS500 - Red

€
9,99

Medium Neoprene

SPECIFICHE

Batticatena in Neoprene misura medium.



CHMDS100 - Black



CHMDS400 - Blue



CHMDS500 - Red

€
10,99

Large Neoprene

SPECIFICHE

Batticatena in Neoprene misura large.

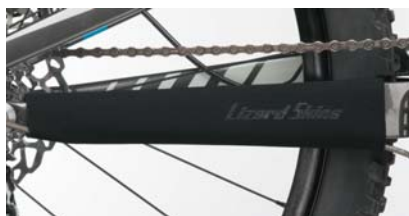

CHLDS100 - Black



CHLDS400 - Blue



CHLDS500 - Red

€
11,99

Carbon Leather Patches

SPECIFICHE

Protezioni telaio adesive per le zone di passaggio delle guaine cavetti. 6 pezzi "carbon look".

CODICE

LBPDS100



€
8,99

Clear Patches

SPECIFICHE

Protezioni telaio adesive per le zone di passaggio delle guaine cavetti. 6 pezzi trasparenti.

CODICE

CBPDS100



€
7,99

Small Frame Protector Carbon Leather

SPECIFICHE

Protezione adesiva per catena e/o foderi posteriori, "carbon look".

CODICE

LBPDS200



€
10,99

Large Frame Protector Carbon Leather

SPECIFICHE

Protezione adesiva per tubo obliquo o orizzontale, "carbon look".

CODICE

LBPDS300



€
23,99

Small Frame Protector Clear

SPECIFICHE

Protezione adesiva per catena e/o foderi posteriori, trasparente.

CODICE

CBPDS200



€
8,99

Large Frame Protector Clear

SPECIFICHE

Protezione adesiva per tubo obliquo o orizzontale, trasparente.

CODICE

CBPDS300

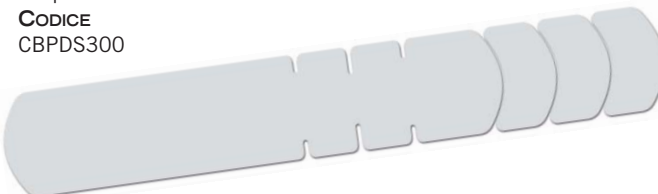

€
16,99

Frame Kit

€
44,99

SPECIFICHE

Kit per proteggere da cima a fondo il telaio.
Protezioni adesive trasparenti.

CODICE

CBPDS500



Fork Protector Clear

€
25,99

SPECIFICHE

Protezione adesiva foderi forcella, trasparente.

CODICE

CBPDS400

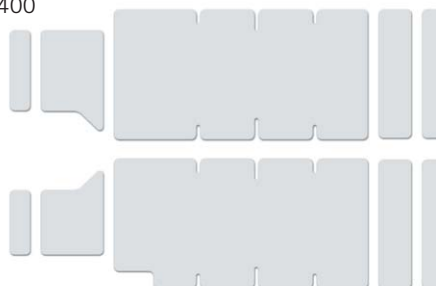

Manopole DSP

€
32,90

SPECIFICHE

Manopole diametro 30,3 (27g.)
oppure 32,3mm (30g.)

COLORI

DSPDST10 - Black
DSPDST20 - White
DSPDST40 - Blue
DSPDST43 - Sky Blue
DSPDST50 - Red
DSPDST55 - Neon Pink
DSPDST70 - Green
DSPDST87 - Neon



Lock On Peaty

€
31,90

SPECIFICHE

Manopola con la firma di Steve Peat.

COLORI

LOPDS100 - Black
LOPDS300 - Graphite
LOPDS480 - Electric Blue
LOPDS570 - Fire Red
LOPDS875 - Neon
LOPDS975 - Tangerine



Lock On Logo

€
31,90

SPECIFICHE

Manopola logo Lizard Skins.

COLORI

LOLDS010 - Black
LOLDS042 - Ice Blue
LOLDS070 - Lime Green



Lock On Moab

€
31,90

SPECIFICHE

Manopola Moab.

COLORI

LOMDS010 - Black
LOMDS057 - Fire Red
LOMDS087 - Neon



Lock On Northshore

€
31,90

SPECIFICHE

Manopola Northshore.

COLORI

LONDS030 - Graphite
LONDS048 - Electric Blue
LONDS070 - Lime Green
LONDS097 - Tangerine



Lock On Charger

€
31,90

SPECIFICHE

Manopola Charger.

COLORI

LOCDs100 - Black
LOCDs200 - White
LOCDs550 - Pink
LOCDs975 - Tangerine



Lock On Bearclaw

SPECIFICHE
Manopola Bearclaw.
COLORI
LODDS100 - Black
LODDS200 - White
LODDS420 - Ice Blue



€
31,90



Lock On Macaskill

SPECIFICHE
Manopola Danny Macaskill.
COLORI
LOMAC100 - Jet Black
LOMAC480 - Electric Blue
LOMAC570 - Fire Red
LOMAC720 - Lime Green
LOMAC875 - Neon
LOMAC975 - Tangerine



€
31,90



Lock On Expert Machine

SPECIFICHE
Manopola Expert Machine.
COLORI
LOEDS100 - Black



€
31,90

Logo Dual

SPECIFICHE
Manopola in Kraton/gel, logo Lizard Skins.
COLORI
DDMDS100 - Black
DDMDS400 - Blue



€
9,99



100 Bar Plugs

SPECIFICHE
Tappi manubrio.
CODICE
PLUDS100



€
1,50

Logo Single Compound

SPECIFICHE
Manopola a miscela unica.
COLORI
SCLDS100 - Black



€
9,99

Moab Single Compound

SPECIFICHE
Manopola a miscela unica.
COLORI
MOADS010 - Black
MOADS050 - Red



€
9,99

Northshore Single Compound

SPECIFICHE
Manopola a miscela unica.
COLORI
NORDS010 - Black
NORDS030 - Graphite



€
9,99

Charger Single Compound

SPECIFICHE
Manopola a miscela unica.
COLORI
CHADS100 - Black
CHADS200 - White
CHADS550 - Pink
CHADS900 - Orange



€
9,99



494 Single Compound

SPECIFICHE
Manopola a miscela unica.
COLORI
494DS100 - Black
494DS250 - Clear
494DS300 - Graphite



€
9,99



Mini Machine Single Compound

SPECIFICHE
Manopola a miscela unica.
COLORI
MIMDS100 - Black
MIMDS550 - Hot Pink



€
10,99



Micro Cache

€
21,90

SPECIFICHE

Borsello sottosella.

COLORI

SBGDS10S - Jet Black
SBGDS30S - Lead
SBGDS40S - Electric Blue
SBGDS50S - Crimson



Cache

€
24,90

SPECIFICHE

Borsello sottosella.

COLORI

SBGDS10M - Jet Black
SBGDS30M - Lead
SBGDS40M - Electric Blue
SBGDS50M - Crimson



Super Cache

€
27,99

SPECIFICHE

Borsello sottosella.

COLORI

SBGDS10L - Jet Black
SBGDS30L - Lead
SBGDS40L - Electric Blue
SBGDS50L - Crimson



Dry Fiant Shoe

€
36,90

SPECIFICHE

Copriscarpe resistente all'acqua.

MISURE

DRYSC10S - Small
DRYSC10M - Medium
DRYSC10L - Large
DRYSC10X - Xlarge
DRYSC10Z - XXLlarge



Dry Fiant Insulated

€
43,90

SPECIFICHE

Copriscarpe resistente all'acqua.

MISURE

DRYIC10S - Small
DRYIC10M - Medium
DRYIC10L - Large
DRYIC10X - Xlarge



Dry Fiant Toe

€
26,90

SPECIFICHE

Copriscarpe resistente al vento.
Fodera in micropile. Logo riflettente.

MISURE

DRYTC10S - Small
DRYTC10M - Medium
DRYTC10L - Large
DRYTC10X - Xlarge



Rear Boot

€
7,99

SPECIFICHE

Protezione in Neoprene ammortizzatore posteriore.

CODICE

RSBDS100



Fork Boot

€
12,99

SPECIFICHE

Protezione in Neoprene forcella.

CODICE

FBCDS100



Headset Seal

€
2,99

SPECIFICHE

Protezione serie sterzo.

CODICE

HSSDS100



Grips Donuts

€
2,99

SPECIFICHE

Protezione leva freno antiscivolo.

CODICE

BMXDS100 - Black
BMXDS400 - Blue
BMXDS500 - Red



LUMOS

LUMOS®



★dsb★

SEMPLICEMENTE BICI



Casco Lumos

Si parla sempre di più di sicurezza e soprattutto per noi ciclisti, essere visti è indispensabile. LUMOS ha creato un casco unico che oltre alla luce di visibilità ha incorporato le frecce di direzione. Il tutto completamente ricaricabile.

€
199,00

- Luci a led anteriori
- Luci a led posteriori
- Frecce di direzione
- Sicurezza casco CE
- Comando wireless
- Smartphone App
- Taglia unica
- Colori Black, Pearl White, Cobalt blue, Green.



LUMOS

MUCKY NUTZ



★ d s b ★

SEMPLICEMENTE BICI

Face Fender

€
12,99

SPECIFICHE

Parafango leggero e versatile, solo 25 g. Lacci in velcro rendono molto facile e veloce il montaggio e la rimozione.

COLORI

Black, White, Blue, Magenta, Red, Orange, Yellow, Total White.



Face Fender XL

€
15,99

SPECIFICHE

Parafango Face Fender in versione extra lunga.

COLORI

Black, White, Bleu, Red, Green, Orange, Yellow.



Full Face Fender

€
18,99

SPECIFICHE

Parafango.

COLORI

Black.



Fat Face Fender

€
19,99

SPECIFICHE

Parafango per Fat Bike.

COLORI

Black.



Gut Fender

€
12,99

SPECIFICHE

Parafango per tubo obliquo.

COLORI

Black, White, Blue, Red, Green, Orange, Yellow.



Fat Gut Fender

€
15,99

SPECIFICHE

Parafango per tubo obliquo per Fat Bike.

COLORI

Black.



Butt Fender

€
12,99

SPECIFICHE

Parafango posteriore. Si fissa alla sella.

COLORI

Black.



Fat Butt Fender

€
12,99

SPECIFICHE

Parafango posteriore per Fat Bike.

COLORI

Black.



Rear Fender

€
16,99

SPECIFICHE

Parafango posteriore. Si fissa al Seat Tube.

COLORI

Black.



ORTLIEB WATERPROOF



★ d s b ★

SEMPLICEMENTE BICI

Seat-Pack L

SPECIFICHE

Borsa per sella impermeabile con chiusura a rotolo; montaggio con robusta chiusura a strappo e cinghia di compressione; capacità 16,5 litri; fissaggio esterno tramite cordino elastico; valvola per la compressione del volume; fondo rigido; tessuto in nylon rivestito in PU e resistente agli strappi.

CODICE
F9901



€
147,00

Seat-Pack M

SPECIFICHE

Borsa per sella impermeabile con chiusura a rotolo; montaggio con robusta chiusura a strappo e cinghia di compressione; capacità 8 litri; fissaggio esterno tramite cordino elastico; valvola per la compressione del volume; fondo rigido; tessuto in nylon rivestito in PU e resistente agli strappi.

CODICE
F9911



€
137,00

Handlebar-Pack M

SPECIFICHE

Borsa da manubrio impermeabile capacità 16,5 litri; chiusura a rotolo su entrambi i lati per un accesso ottimale al contenuto; cinghia di compressione; distanziatori per il montaggio su diversi tipi di manubrio; cinghie con chiusura a strappo per un semplice montaggio; fissaggio esterno tramite cordino elastico; aggancio per l'Accessory-Pack; tessuto in nylon rivestito in PU e resistente agli strappi.

CODICE
F9921



€
116,00

Handlebar-Pack S

SPECIFICHE

Borsa da manubrio impermeabile capacità 11 litri; chiusura a rotolo su entrambi i lati per un accesso ottimale al contenuto; cinghia di compressione; distanziatori per il montaggio su diversi tipi di manubrio; cinghie con chiusura a strappo per un semplice montaggio; fissaggio esterno tramite cordino elastico; aggancio per l'Accessory-Pack; tessuto in nylon rivestito in PU e resistente agli strappi.

CODICE
F9931



€
105,00

Gravel-Pack

SPECIFICHE

Borsa da bicicletta universale, impermeabile, con chiusura a rotolo; installabile su low rider oppure su portapacchi posteriore; sistema Quick-Lock 2.1 su portapacchi di diametro fino a 16mm; gancio di fissaggio inferiore supplementare; tessuto di nylon rivestito in PU resistente allo sfregamento; catarifrangenti.

CODICE
F9981



€
126,00

Accessory-Pack

SPECIFICHE

Borsa da manubrio compatta per l'espansione dell'Handlebar-Pack; accesso rapido al contenuto tramite chiusura a rotolo con ganci di arresto; montabile anche separatamente sul manubrio con cinghie a strappo; utilizzabile come marsupio o borsa a spalla per mezzo della cinghia in dotazione; tessuto in nylon rivestito in PU e resistente agli strappi.

CODICE
F9951



€
58,00

Frame-Pack Toptube

SPECIFICHE

Borsa per telaio con chiusura lampo impermeabile; ideale la combinazione con il supporto per borraccia sul triangolo; cinghie a strappo ad alta aderenza per il montaggio; tessuto in nylon rivestito di PU. Capacità 4 litri.

CODICE
F9941

€
105,00



Frame-Pack

SPECIFICHE

Borsa da telaio con chiusura lampo impermeabile; cinghia regolabile con chiusura a strappo; banda interna in velcro per impedire il rigonfiamento eccessivo della borsa; tessuto in nylon rivestito in PU e resistente agli strappi.

€
126,00

L - 6 litri
CODICE F9972

€
105,00

M - 4 litri
CODICE F9971



Cockpit-Pack

SPECIFICHE

Borsa per tubo superiore, compatta e impermeabile, per una presa rapida; cinghie a strappo ad alta aderenza per il montaggio; corpo della borsa impunturato; tessuto in nylon rivestito di PU, resistente allo sfregamento.

CODICE
F9961

€
53,00



Fixing Strap for Seat-Pack

SPECIFICHE

Cinghia di fissaggio aggiuntiva in Nylon colore arancio per Seat-Pack.

CODICE
E216

€
9,00



Back-Roller Plus

SPECIFICHE

Borsa posteriore con chiusura a rotolo; sistema QL2.1 fino a diametro di 16mm, Cordura plasmata PU, tasca interna, grandi riflettori, tracolla.

€
149,00



F5201
Lime-Moss Green



F5202
Signal Red-Dark
Chili



F5203
Denim-Steel Blue



F5204
Granite-Black

Sport-Roller Classic

SPECIFICHE

Borsa universale con chiusura a rotolo per portapacchi anteriori o posteriori; sistema QL2.1 fino a diametro di 16mm, PVC rivestito in tessuto poliestere, tasca interna, compresi riflettori e tracolla.

€
113,00



F6301
Black



F6302
Red-Black



F6303
Ultramarine-Black



F6304
Yellow-Black



F6305
Asphalt-Black

Ultimate 6 Classic

SPECIFICHE

Borsa manubrio con serratura chiusura magnetica della copertura. Per manubri fino a 31,8 mm di diametro. PVC rivestito in tessuto poliestere, tasca interna, tracolla, riflettore. Compatibile con l'attaccoKLICKx Rixen & Kaul.

€
86,00

M - 7 litri

€
90,00

L - 8,5 litri
CODICE F3203
Asphalt-Black



F3111
Red-Black



F3112
Ultramarine-Black



F3110
Black



F3113
Yellow-Black



F3114
White-Black



F3115
Asphalt-Black

Downtown 2 QL3.1

SPECIFICHE

Borsa portadocumenti con chiusura a rotolo; sistema Quick-Lock3.1; disponibile a scelta in tessuto Cordura rivestito di PU oppure in poliestere rivestito di PVC; utilizzabile a sinistra o a destra del portapacchi grazie ai binari di supporto orientabili; tracolla imbottita staccabile.

€
168,00

Cordura

€
158,00

Poliestere



F7251
Black (Cordura)

F7252
Steelblue (Cordura)



F7253
Black (Poliestere)



F7254
White-Black (Poliestere)

Back-Roller Design

SPECIFICHE

Borsa posteriore con chiusura a rotolo; sistema QL2.1 fino a diametro di 16mm, PVC rivestito in tessuto in poliestere, tre modelli ciascuno in diverse combinazioni di colori, una tasca interna, grandi riflettori, tracolla.

€
74,00



ONE LESS CAR
F5474 Olive-Black



CYCLEDELIC
F5475 White-Black



WOODLAND
F5476 Mint-Black



UPHILL
F5477 White-Black

Velocity

SPECIFICHE

Daypack 24 litri in stile courier bag, chiusura a rotolo, tasca interna rimovibile con cerniera parasigoli, schiuma ammortizzante posteriore, supporto opzionale per luce posteriore o casco, supporto anatomico con cinturino sterno e cintura in vita, maniglia di trasporto.

€
97,00



R4003
Yellow-Black



R4009
Lime-Black



R4005
Black



R4201
15 litri Pepper

R4251
15 litri Pepper



R4202
15 litri Coffee

R4252
20 litri Coffee



R4203
15 litri Ink

R4253
20 litri Ink

€
130,00

20 litri

€
105,00

15 litri

Urban Daypack

SPECIFICHE

Zaino per l'uso quotidiano in città, in due misure, patta pieghevole con chiusura lampo; tracolla e manico morbidi; scomparto interno adatto al formato A4; tasca frontale nel modello da 20 litri (non impermeabile).

Sport-Roller High Visibility

€
193,00

SPECIFICHE

Borsa universale 25 litri con chiusura a rotolo per portapacchi anteriori o posteriori, sistema QL2.1 fino a diametro 16mm; tessuto laminato PU con un lato riflettente; tasca interna; compresi riflettori e tracolla.



F6151
Neon Yellow-Black
Reflective

F6152
Black Reflective

Office-Bag High Visibility

€
173,00

SPECIFICHE

Cartella portadocumenti da bicicletta con chiusura a rotolo; sistema Quick-Lock2.1 per tubo portapacchi fino a diametro 16mm; tessuto rivestito in PU con fibre catarifrangenti incorporate; montaggio a destra o a sinistra del portapacchi. Tracolla, angoli rinforzati, catarifrangenti.

CODICE
F70971



Micro

€
25,50

SPECIFICHE

Borsa da sella per strada e mountain bike; chiusura a rotolo con elastici per il fissaggio stabile, volume minimo (4 litri), riflettore.



F9653
Signal Red-Orange



F9651
Slate-Black



F9652
Light Green-Lime



F9656
Ocean Blue

Messenger Bag

€
116,00

SPECIFICHE

Borsa 39 litri con chiusura a rotolo, spallacci sagomati con nastro riflettente, rivestito in spugna imbottita, protezione sui bordi.



F2303
Orange-Black



F2307
Ocean Blue-Black



F2306
White-Black



F2305
Black



F2304
Red-Black

Gear-Pack

SPECIFICHE

Ibrido borsa/zaino impermeabile disponibile in tre misure con sistema di trasporto staccabile; cinghia staccabile altezza fianchi; tracolla staccabile con 3 regolazioni in lunghezza; tasca esterna in rete rimovibile; imbottitura posteriore estraibile (utilizzabile come sedile); daisy chain sul davanti e di lato; manico; cinghia di fissaggio per fune.



R17002
25 litri Black-Sun

R17102
32 litri Black-Sun

R17152
40 litri Black-Sun



R17001
25 litri Black

R17101
32 litri Black

R17151
40 litri Black



R17003
25 litri Black-Red

R17103
32 litri Black-Red

R17153
40 litri Black-Red

€
137,00

25 litri

€
147,00

32 litri

€
158,00

40 litri

Duffle RG

SPECIFICHE

Borsa da viaggio in tre misure con sistema di rulli e maniglia telescopica; leggera e robusta, tessuto impermeabile e robusto in cordura e poliestere; chiusura lampo a prova d'acqua con TiZip, chiudibile a chiave con lucchetto disponibile separatamente.

Piedini di sostegno; funzione zaino grazie agli spallacci larghi; compressione interna; tasca interna; tasca esterna in rete; la versione da 34 litri è adatta come bagaglio a mano per la maggior parte delle compagnie aeree.



Black
K12001 - 34 litri
K12101 - 60 litri
K12201 - 85 litri



Sunyellow-Black
K12002 - 34 litri
K12102 - 60 litri
K12202 - 85 litri



€
284,00

34 litri

€
300,00

60 litri

€
322,00

85 litri

Dry Bag

SPECIFICHE

Robusta borsa con chiusura roll, tessuto di poliestere.



Black-Slate
K4051 - 5 litri
K4151 - 7 litri
K4351 - 10 litri
K4451 - 13 litri
K4551 - 22 litri
K4651 - 35 litri
K4751 - 59 litri
K4851 - 79 litri
K4951 - 109 litri



Cranberry-Signalred
K4051 - 5 litri
K4151 - 7 litri
K4351 - 10 litri
K4451 - 13 litri
K4551 - 22 litri
K4651 - 35 litri
K4751 - 59 litri
K4851 - 79 litri
K4951 - 109 litri



Yellow-Sunyellow
K4051 - 5 litri
K4151 - 7 litri
K4351 - 10 litri
K4451 - 13 litri
K4551 - 22 litri
K4651 - 35 litri
K4751 - 59 litri
K4851 - 79 litri
K4951 - 109 litri

€
15,00

5 litri

€
16,00

7 litri

€
17,00

10 litri

€
18,00

13 litri

€
19,00

22 litri

€
22,50

35 litri

€
27,00

59 litri

€
30,00

79 litri

€
34,50

109 litri

RACE FACE

**RACE
FACE**



★dsb★

SEMPLICEMENTE BICI

Next SL G4

SPECIFICHE

Guarnitura in carbonio. Lunghezza 170, 175mm.
26/38, 28/40, 24/38, 22/36, 24/34,
26/36, 28/38.

Compatibile Eagle.

COLORI

Base nera con logo Next
Bianco, Arancio, Rosso,
Blu.



€
579,00

doppia

€
499,00

singola

€
449,00

senza corone

€
449,00

fat 100-190mm

Sixx

SPECIFICHE

Guarnitura in carbonio. La più leggera del mercato
per uso FR / DH.

Lunghezza 165, 170, 175mm. Anche 83 (no 175).
Disponibile singola 36.



€
449,00

singola

€
399,00

senza corona

€
449,00

versione BMX

Spider Next

SPECIFICHE

Per doppie e triple.

€
49,90

Next R

SPECIFICHE

Guarnitura in carbonio per Enduro.
Lunghezza 170, 175mm.
495g. con corona da 32.



€
499,00

singola

€
449,00

senza corona

Crank Boot

SPECIFICHE

Protezione per pedivelle. Anche versione small
per pedivelle in alluminio.

COLORI

Black, Grey, Red, Blue, Green, Torquise, Orange, Pink.

€
7,90



Spindle Power Meter

SPECIFICHE

Misuratore di potenza per pedivelle Cinch.



€
849,00

Turbine

SPECIFICHE

Guarnitura in alluminio.
Lunghezza 170, 175mm.

COLORI

Black.



€
299,00

singola

€
249,00

senza corona

€
249,00

senza corone
Fat 170 - 190

Atlas

SPECIFICHE

Guarnitura in alluminio, lunghezza 165, 170, 175mm anche 83 (no 175).

Corona e movimento centrale non compresi.

COLORI

Black, Blue, Green, Red.



€
199,90

Respond

SPECIFICHE

Guarnitura in alluminio, lunghezza 83, 165, 170, 175mm.

Corone non comprese.

COLORI

Black.



€
179,90

Aeffect

SPECIFICHE

Lunghezza 170, 175mm.

Movimento centrale non compreso.

COLORI

Black.



€
179,90

doppia

€
179,90

singola

€
139,90

senza corone

Chester

SPECIFICHE

Lunghezza 83, 165, 170, 175mm.

Corone non comprese.

COLORI

Black.



€
129,90

senza corona

€
139,90

da 83

Aeffect e-bike

SPECIFICHE

Pedivelle specifiche per e-bike 165, 170, 175mm.



€
129,90

Pedali Atlas

SPECIFICHE

Pedali in alluminio.

Dimensione piattaforma 101x114 mm.

Peso 355g.

COLORI

Black, Red,
Blue, Green,
Orange, Purple.



€
159,90



Pedali Aeffect

€
114,90

SPECIFICHE

Pedali in alluminio.
Dimensione piattaforma 101x100mm.

Peso 375g.

COLORI

Black,
Red, Blue.



Ruote Turbine

€
1.199,00

SPECIFICHE

Canale 30, 28 fori, 27,5 (1.730g) e 29 (1.815g)
100/110 e 142/148.



Pedali Chester

€
64,90

SPECIFICHE

Pedali in composito.

COLORI

Black, Blue, Red, Green, Orange, Yellow, Purple.



Ruote Aeffect R

€
749,00

SPECIFICHE

Canale 30, 28 fori,
27,5 (1.810g)
e 29 (1.930g)
100/110
e 142/148.



Ruote Next R

€
1.899,00

SPECIFICHE

Ruote in carbonio,
canale 31mm.
27,5 (1.680g).
29 (1.765g).



Ruote Turbine old

€
400,00

SPECIFICHE

Ruote Turbine vecchio modello 27,5 15/100 - 142.
Fino ad esaurimento scorte.

Cerchio ARC

€
99,90

SPECIFICHE

Canale da 30 o da 35.
27,5 e 29.

€
119,90



Canale da 40

BB30 BSA - BB30 BB92

SPECIFICHE

Compatibile con BB30, PF92 o BSA.



€
49,90

Press Fit BB92

SPECIFICHE

BB, X-TYPE, 41mm PRESS FIT (BB92).



€
59,90

BB30 Convert 68/73

SPECIFICHE

Per montare pedivelle con asse da 24mm su movimento centrale BB30.



€
49,90

Corone Narrow 104

SPECIFICHE

Corone con denti Narrow Wide, compatibili con trasmissioni monocorona.

Interasse fuori 104 mm.

Compatibili Sram 30-36-38.

COLORI

Black, Blue, Red, Green, Orange, Purple.



€
59,90

30-36-38

€
49,90

32-34

€
59,90

38-40-42 x 110
e 40-42-44 x 130

Corone Cinch

SPECIFICHE

Compatibili Sram.

24-26-28-30-32-34-36-38-40-42.

COLORI

Black, Blue, Red, Green, Orange, Purple.



€
64,90

Set Corone Turbine XC

SPECIFICHE

24/32/42,

22/32-22/36-24/36-24/38-26/38-28/40.



€
129,90

Corone Turbine

SPECIFICHE

22-24, 32-34, 36, 42,
26-28 per 2x10, 38-40 per 2x10.



€
34,90

22 - 24

€
59,90

32 - 34

€
69,90

36

€
79,90

42

€
64,90

26-28
per 2x10

€
74,90

38-40
per 2x10

Corone 4 fori e compact

SPECIFICHE

20-22-24, 32-34-36, 42-44-46.



€
37,90

20-22-24

€
59,90

32-34-36

€
79,90

42-44-46

Protezione corone

SPECIFICHE

Protezione corone 32, 36, 40 anche per FAT su ordinazione.

COLORI

Black, Blue, White, Red.



€
59,90

Turbine 35

SPECIFICHE

Attacco manubrio, lunghezza 50, 60, 70, 80, 90mm.

COLORI

Black.



€
99,90

Turbine

SPECIFICHE

Attacco manubrio, lunghezza 60, 70, 90, 110mm.

COLORI

Black.



€
99,90

Turbine R 35

SPECIFICHE

Attacco manubrio, lunghezza 32, 40, 50, 60, 70mm.

COLORI

Black.



€
109,90

Atlas 35

SPECIFICHE

Attacco manubrio, lunghezza 35, 50, 65mm. Anche Direct Mount 50.

COLORI

Black.



€
99,90

Atlas Direct Mount

SPECIFICHE

Attacco manubrio, lunghezza 50/30 rev.

COLORI

Black, Red, Blue, White, Stealth.



€
99,90

Atlas

SPECIFICHE

Attacco manubrio, lunghezza 50, 65mm.

COLORI

Black, Red, Blue.

€
99,90



Respond

SPECIFICHE

Attacco manubrio, lunghezza 45, 60mm +10°

COLORI

Black.

€
49,90



Chester

SPECIFICHE

Attacco manubrio, lunghezza 50, 70mm.

COLORI

Black.

€
49,90



Chester 35

SPECIFICHE

Attacco manubrio, lunghezza 40, 60mm.

COLORI

Black.

€
49,90



Aeffect R 35

SPECIFICHE

Attacco manubrio, lunghezza 35, 50, 60, 70mm.

COLORI

Black.

€
59,90



Aeffect 35

SPECIFICHE

Attacco manubrio, lunghezza 50, 60, 70, 80, 90mm.

COLORI

Black.

€
49,90



Ride

SPECIFICHE

Attacco manubrio, lunghezza 60, 70, 90, 100, 110, 120mm, 6°.

COLORI

Black.

€
29,90



Turbine Dropper

SPECIFICHE

Reggisella telescopico con comando remoto.
Ø 30,9-31,6mm.
Escursione 125, 150, 175mm.
Peso 495g.
Comando non incluso.

COLORI

Black, Blue, Red, Green.

€
449,00



Comando Turbine Dropper

€
59,90

SPECIFICHE

Comando per reggisella Turbine Dropper.

COLORI

Black, Red, Green, Blue, Orange, Purple.



Aeffect Dropper

SPECIFICHE

Reggisella telescopico con comando remoto.
Ø 30,9, 31,6mm.
Escursione 125, 150mm.
Peso 570g (31,6x150x425)
Comando non incluso.

COLORI

Black, Blue, Red, Green.

€
279,90

Esc. 125mm

€
329,90

Esc. 150mm



Comando Aeffect Dropper

€
49,90

SPECIFICHE

Comando per reggisella Aeffect Dropper.

COLORI

Black.



Next

SPECIFICHE

Reggisella in carbonio.
Ø 27,2, 30,9, 31,6mm.
Lunghezza 400mm.
Peso 250g.

€
159,90



Sixc I-Beam

SPECIFICHE

Reggisella in composito.
Ø 30,9, 31,6mm.
Lunghezza 350mm.
Peso 190g.

€
129,90



Turbine

SPECIFICHE

Reggisella in alluminio.
Ø 27,2, 30,0, 30,9, 31,6mm.
Lunghezza 400mm.

€
69,90



Atlas I-Beam

SPECIFICHE

Reggisella in alluminio.
Ø 30,9, 31,6mm.
Lunghezza 350mm.
Peso 218g.

€
69,90



Chester

SPECIFICHE

Reggisella in alluminio.
Ø 27,2, 30,9, 31,6mm.
Lunghezza 325mm.
Peso 231g.

€
32,90



Ride

SPECIFICHE

Reggisella in alluminio.
Ø 27,2, 31,6mm.
Lunghezza 350mm.
Peso 295g.

€
32,90



Sella Aeffect

SPECIFICHE

Utilizzo XC / AM / DH.
Dimensioni 290x132mm.
Peso 240g.

COLORI

Black, Red, Blue.

€
79,90



Sella Atlas

SPECIFICHE

Utilizzo DH / FR. Dimensioni 260x127mm.
Dimensioni 260x127mm.
Peso 156g. I-Beam, 220g. Railed.

COLORI

Black, Red, Blue.

€
69,90

I-Beam

€
74,90

Railed



Next R 35

SPECIFICHE
Piega in carbonio Ø 35mm.
Lunghezza 800mm.
Rise 10, 20, 35mm
COLORI
Black.



€
159,90

Turbine 35

SPECIFICHE
Piega in alluminio Ø35mm, XC / Trail.
Lunghezza 760, 800mm.
Peso 300g.
COLORI
Black.



€
79,90

€
84,90

760mm
800mm

Next 35

SPECIFICHE
Piega in carbonio Ø 35mm.
Lunghezza 760mm.
COLORI
Grey, Turquoise, Blue,
Red, Green, Stealth,
Orange.



€
149,90

Turbine Flat Wide

SPECIFICHE
Piega in alluminio piatta
Ø 31,8mm, lunghezza 720mm.
COLORI
Black.



€
79,90

Next 3/4 Rise

SPECIFICHE
Piega in carbonio rialzata 0,75"
Ø 31,8mm, lunghezza 725mm,
rise 19mm, peso 175g.
COLORI
Blue, Red,
Green, Silver.



€
149,90

Turbine 3/4

SPECIFICHE
Piega in alluminio rialzata 0,75".
Ø 31,8mm, lunghezza 725mm,
rise 19mm, peso 290g.
COLORI
Black, Red, Blue,
Gold, Orange.



€
79,90

Sixc 35

SPECIFICHE
Piega in carbonio Ø 35mm.
Lunghezza 800, 820mm, peso 235g.
COLORI
Silver, Red, Blue,
Green, Stealth,
Orange.



€
149,90

800mm

€
169,90

820mm

Atlas 35

SPECIFICHE
Piega in alluminio, rise 20mm.
Lunghezza 800mm, peso 300g.
COLORI
Black, Red, Blue, Gold,
Orange, Stealth, Raw, Green.



€
79,90

Sixc

SPECIFICHE
Piega in carbonio Ø 31,8mm AM / FR.
Lunghezza 785mm, peso 220g.
COLORI
Black, Green, Blue, Red.



€
149,90

Atlas

SPECIFICHE
Piega in alluminio rialzata 0,50", 1,25".
Rise 13, 32mm.
Lunghezza 785mm. Peso 785g.
COLORI
Black, Blue, Orange,
Red, Raw.



€
79,90

Atlas Flat

SPECIFICHE

Piega in alluminio piatta Ø 31,8mm AM / DH / FR.
Lunghezza 785mm.
Peso 315g.

COLORI

Black.



€
79,90

Chester

SPECIFICHE

Piega in alluminio rialzata,
lunghezza 740mm.
Peso 400g.

COLORI

Black.



€
44,90

Aeffect 35

SPECIFICHE

Piega in alluminio Ø 35mm rialzata 0,75".
Lunghezza 760mm, 10 e 20mm rise.
Peso 335g.

COLORI

Black.



€
49,90

Ride Low Riser

SPECIFICHE

Piega in alluminio rialzata, Ø 31,8mm
lunghezza 710mm, peso 343g.

COLORI

Black.



€
34,90

Respond

SPECIFICHE

Piega in alluminio AM / DH / FR.
Rise 13mm, 38mm.
Lunghezza 780mm.
Peso 360g.

COLORI

Black.



€
49,90

Half Nelson

SPECIFICHE

Manopole con Lock-On XC / AM / DH.
Ø 29mm, peso 92,5g.

COLORI

Black, Blue, Green, Red,
Orange, Grey, White,
Yellow, Turquoise.



€
24,90

Chester 35

SPECIFICHE

Piega in alluminio AM / DH / FR.
Lunghezza 785mm, 10, 20, 35mm rise.

COLORI

Black.



€
44,90

Love Handle

SPECIFICHE

Manopole in silicone XC / AM / DH.
Ø 28-33mm, peso 98g.

COLORI

Black, Blue, Red,
Purple, Orange,
Pink, Yellow.



€
27,90

Agent Softshell

SPECIFICHE

Giacca impermeabile.

COLORI

Black, Blue, Red.



€
199,00

Ruxton Shorts

SPECIFICHE

Pantaloncini.

COLORI

Sulphur.



€
129,00

Nano Jacket

SPECIFICHE

Giacca impermeabile superleggera con zip 3/4.

COLORI

Black, Blue, Dune.



€
109,90

Indy Shorts

SPECIFICHE

Pantaloncini.

COLORI

Red-Black.



€
69,90

Scout Women Jacket

SPECIFICHE

Giacca da donna.

COLORI

Black, Blue.



€
169,00

Indy Jersey

SPECIFICHE

Maglia manica corta.

COLORI

Sulphur, Turquoise.



€
54,90

Stash Man Bib Storage

SPECIFICHE

Bib con bretelle e posteriore con tasche.

COLORI

Black.



€
119,90

Trigger Shorts

SPECIFICHE
Pantaloncini.
COLORI
Black,
Turquoise.



€
84,90

Ambush Core

SPECIFICHE
Maglia con protezioni in D30. Taglie S-M-L-XL.



€
119,90

Trigger Jersey

SPECIFICHE
Maglia.
COLORI
Black, Turquoise.



€
49,90

Flank Liner

SPECIFICHE
Sotto pantaloncini con protezioni.



€
99,90

Agent Winter Shorts

SPECIFICHE
Pantaloncini impermeabili.
COLORI
Black.



€
129,90

Flank Leg

SPECIFICHE
Protezioni ginocchia lunghe in D30.



€
119,90

Ambush Knee

SPECIFICHE

Protezioni ginocchia corte in D30.

€
94,90



Ambush Elbow

SPECIFICHE

Protezioni gomiti in D30.

€
69,90



Indi Knee

SPECIFICHE

Protezioni ginocchia studiate per l'Enduro.

€
89,90



Indi Elbow

SPECIFICHE

Protezioni gomiti studiate per l'Enduro.

€
54,90



Charge leg

SPECIFICHE

Protezione leggera da poter tenere tutto il giorno.

€
39,90



Dig Knee

SPECIFICHE
Protezioni ginocchia.

€
74,90



Dig Elbow

SPECIFICHE
Protezioni gomiti.

€
59,90



RACE FACE

RESERVE



★ d s b ★

SEMPLICEMENTE BICI

Ruote Reserve con Mozzi DT Swiss 350

€
1,899,00

SPECIFICHE

Ruote realizzate da Santa Cruz, cerchi in carbonio con garanzia a vita. Larghezza cerchio da 25, 27 o 30 mm per le 29" e 27 e 30 mm per le Reserve da 27,5".

Ruote Reserve con Mozzi Industry Nine Torch

€
2,299,00



RESERVE 29"

<p>RESERVE 25 C: 29-inch ID: 25mm OD: 30.6mm D: 22mm W: 390g U: XC Highball</p> <p>Early July - OE Fall 2017 AM</p>	<p>RESERVE 27 C: 29-inch ID: 27mm OD: 34mm D: 25mm W: 455g U: TR Tallboy, Hightower Joplin</p> <p>Early July - OE Fall 2017 AM</p>	<p>RESERVE 30 C: 29-inch ID: 30mm OD: 36.4 D: 25.4mm W: 490g U: AM</p> <p>Early July - OE Fall 2017 AM</p>

RESERVE 27.5"

<p>RESERVE 27 C: 27.5-inch ID: 27mm OD: 33.5mm D: 22.7mm W: 435g U: TR Bronson, 5010 Roubion, Furtado</p> <p>Early July - OE Fall 2017 AM</p>	<p>RESERVE 30 C: 27.5-inch ID: 30mm OD: 37.4 D: 25.7mm W: 470g U: AM Nomad, Strega</p> <p>June 1 - OE Fall 2017 AM</p>



RESOLVBIKE



★dsb★

SEMPLICEMENTE BICI

ResolvBike 1000ml

SPECIFICHE

Il ResolvBike® il primo prodotto "tutto in uno" per la pulizia completa della bicicletta e non solo. Con trigger.



€
12,00

ResolvBike ricariche

Ricarica da 1000ml.

€
10,00



Tanica 5 litri.

€
33,00

Tanica 10 litri.

€
61,00

Tanica 20 litri.

€
111,00

4C 500ml ricarica concentrata.

€
14,00

ResolvWear

SPECIFICHE

Detersivo tecnico per capi tecnici e sportivi.



€
9,50

ResolvRapid 400 ml

SPECIFICHE

Pulitore senza risciacquo per telai, carbonio, vetri, maschere, lenti, plastica, ecc.



€
8,90

ResolvShine 400 ml

€
8,90

SPECIFICHE

Spray al silicone lucidante, protettivo, antiadesivo per fango.



ResolvBrake 500 ml

€
9,50

SPECIFICHE

Spray specifico per freni a disco e pastiglie con additivo anti fischio.



Latex Blend

€
19,90

SPECIFICHE

Sigillante, previene e ripara le forature. Bottiglia da 1000ml.





SCOPE

SCOPE



★dsb★

SEMPLICEMENTE BICI

R3

SPECIFICHE

Cerchio in carbonio 30x26.

Raggi Sapim CX, peso 1.440g Tubeless ready.

COLORI

White, Gray, Black.

€
1.399,00



R3 Disco

SPECIFICHE

Cerchio in carbonio 30x26 versione disco.

Raggi Sapim CX, peso 1.477g Tubeless ready.

COLORI

White, Gray, Black.

€
1.399,00



R4

SPECIFICHE

Cerchio in carbonio 45x26.

Raggi Sapim CX, peso 1.520g. Tubeless ready.

COLORI

White, Gray, Black.

€
1.399,00



R4 Disco

SPECIFICHE

Cerchio in carbonio 45x26 versione disco.

Raggi Sapim CX, peso 1.557g. Tubeless ready.

COLORI

White, Gray, Black.

€
1.399,00



R5

SPECIFICHE

Cerchio in carbonio 55x26.

Raggi Sapim CX, peso 1.595g.

Tubeless ready.

COLORI

White, Gray, Black.

€
1.399,00



R5 Disco

SPECIFICHE

Cerchio in carbonio 55x26 versione disco.

Raggi Sapim CX, peso 1.632g.

Tubeless ready.

COLORI

White, Gray, Black.

€
1.399,00



02

SPECIFICHE

Cerchio in carbonio XC 29.

Raggi Sapim CX, peso 1.380g.

€
1.399,00



SDG



★ d s b ★

SEMPLICEMENTE BICI

Circuit Carbon

SPECIFICHE

Sella per utilizzo Road e XC.
Carrello in carbonio, peso 165g.

€
189,90



Circuit MTN Carbon

SPECIFICHE

Sella per utilizzo Road ma più specifica per MTB.
Carrello in carbonio.

€
189,90



Circuit MTN Ti Alloy

SPECIFICHE

Sella per utilizzo Road ma più specifica per MTB.
Carrello in Ti-Alloy.

€
99,90



Duster RL Ti Alloy

SPECIFICHE

Sella per utilizzo universale.
Carrello Ti-Alloy. Dimensioni 285mm x 137mm.

€
99,90



Duster P Ti Alloy

SPECIFICHE

Sella per utilizzo universale. Carrello in Ti-Alloy.
Dimensioni 285 x 140mm.

€
99,90



Duster P Cromo

SPECIFICHE

Sella per utilizzo universale. Carrello in cromo.
Dimensioni 285 x 140mm.

€
69,90



Ti Fly

SPECIFICHE

La sella superleggera di SDG. Carrello in titanio.

€
129,90



Fly MTN Ti Alloy

SPECIFICHE

Sella ideale per AM, Trail, Enduro, XC.
Flat-Forward consente facilità di movimento in sella
Carrelli in Ti-Lega, dimensioni 260 x 133mm.
Peso 215g.

€
99,90



Fly MTN Cromo

SPECIFICHE

Sella per utilizzo Mtb.

€
69,90



Bel Air RL 2.0 Ti

SPECIFICHE

Sella per utilizzo universale. Carrello in Titanio.

€
129,90



Bel Air RL

SPECIFICHE

La tradizione. Una garanzia. Disponibile con carrello in Ti-Alloy e Cr-Mo, dimensioni 270 x 140mm.

€
99,90



€
69,90

Allure Antiprostattite

SPECIFICHE

Sella antiprostattite o da donna. Carrello in Ti-Alloy. Dimensioni 265 x 143mm.

€
99,90



I Fly 2

SPECIFICHE

La superleggera. Peso 112g. Dimensioni 257 x 128mm.

€
89,90



Reggisella I BEAM

SPECIFICHE

Reggisella in alluminio Ø 27,2 - 30,9 - 31,6mm.

€
79,90



SDG

SOURCE



★ d s b ★

SEMPLICEMENTE BICI

Paragon

€
159,90

SPECIFICHE

È lo zaino più grande di Source, capienza 25 litri (3 litri sacca idrica Widepa, tubo con protezione raggi UV).

Rain Cover incluso.

COLORI
Black/Red, Light Blue.



Ride

€
109,90

SPECIFICHE

Zaino capienza 15 litri (3 litri sacca idrica).

COLORI

Black, Blue, Purple, Light Blue, Yellow.



Rapid 3

€
89,90

SPECIFICHE

Zaino adatto per le uscite di mezza giornata, due tasche, sacca idrica da 3 litri, tubo con protezione raggi UV.

COLORI

Black, Light Blue, Dark Blue/Green.



Fuse 12

€
74,90

SPECIFICHE

Zaino capienza 12 litri (sacca idrica da 3 litri). Rain Cover inclusa.

COLORI

Black/Red, Dark Blue/Green, Light Blue.



Fuse 8

€
69,90

SPECIFICHE

Zaino capienza 8 litri (sacca idrica da 2 litri)

COLORI

Light Blue, Black/Orange.



Brisk

€
59,90

SPECIFICHE

Zaino idrico capienza 3 litri.

COLORI

Black, Orange/Black, Coral Blue.



Dune

SPECIFICHE

Zaino idrico capienza 1,5 litri, per tutti gli sport estremi, si adatta al corpo per mezzo del sistema di cinghie X-Fit.

COLORI

Black/Red, Orange/Yellow.

€
99,90



Hipster

SPECIFICHE

Marsupio idrico lombare da 1,5 litri con bretelle rimovibili.

COLORI

Black/Orange, Coral Blue.

€
84,90



Spry

SPECIFICHE

Zaino idrico da bambino, capienza 1,5 litri.

COLORI

Light Blue/Green.

€
54,90



Widepac

SPECIFICHE

Sacca idrica disponibile in tre capienze.

CODICI

2060220215 - 1,5 litri
2060220202 - 2 litri
2060220203 - 3 litri

€
34,90

1,5 litri

€
32,90

2 litri

€
30,90

3 litri



Widepac Premium Kit

€
39,90

SPECIFICHE

Sacca idrica capienza 3 litri, tubo con protezione raggi UV e Magnetic Clip.

CODICE

2061720203



DIVide

€
44,90

SPECIFICHE

Sacca idrica con due scomparti separati, capienza 3 litri.

CODICE

2061520103



Ultimate Hydration System

€
49,90

3 litri

€
47,90

2 litri

SPECIFICHE

Sacca idrica completa di tubo con protezione UV, Helix Valve, Uta e Magnetic Clip.

CODICE

2061420203 - 3 litri
2061420202 - 2 litri



UtaTube Kit

SPECIFICHE

Kit per ricaricare la sacca senza toglierla dallo zaino. Uta permette di collegare il tubo a una bottiglia o al rubinetto. Tubo + Uta + Helix Valve.

CODICE
2501800000



€
26,90

Drinking Tube + Filter

SPECIFICHE

Tubo completo con filtro Sawyer Mini Filter.

CODICE
2530300200



€
49,90

Weave Covered Tube Kit

SPECIFICHE

Tubo ricoperto con protezione dai raggi UV + Helix Valve.

CODICE
2501500000



€
15,99

Helix Tube Kit

SPECIFICHE

Tubo e valvola Helix Valve.

CODICE
2501600000



€
14,90

Helix Valve

SPECIFICHE

Valvola uscita liquido.

CODICE
2502200200



€
10,90

SQC Connector

SPECIFICHE

Adattatore per connettore rapido per qualsiasi tipo di tubo.

CODICE
2503300000



€
14,90

Brush Kit

SPECIFICHE

Spazzola per pulizia tubo.

CODICE
2120100000



€
14,90

Magnetic Clip

SPECIFICHE

Ferma tubo magnetico.

CODICE
2510600000



€
11,90

Rain Cover

SPECIFICHE

Copertura in Nylon impermeabile per zaini idrici.

CODICE
2510707100



€
14,50

Insulate Sport

SPECIFICHE

Borraccia termica capacità 0,60 litri.

COLORI

2070503060 - Source Logo / Gray,
2070507260 - Ice / Light Blue.



€
19,90

Sport Bottle

SPECIFICHE

Borraccia da bici capacità 0,70 litri.

COLORI

2070407270 - Dark Gray,
2070403070 - Light Blue.



€
7,90

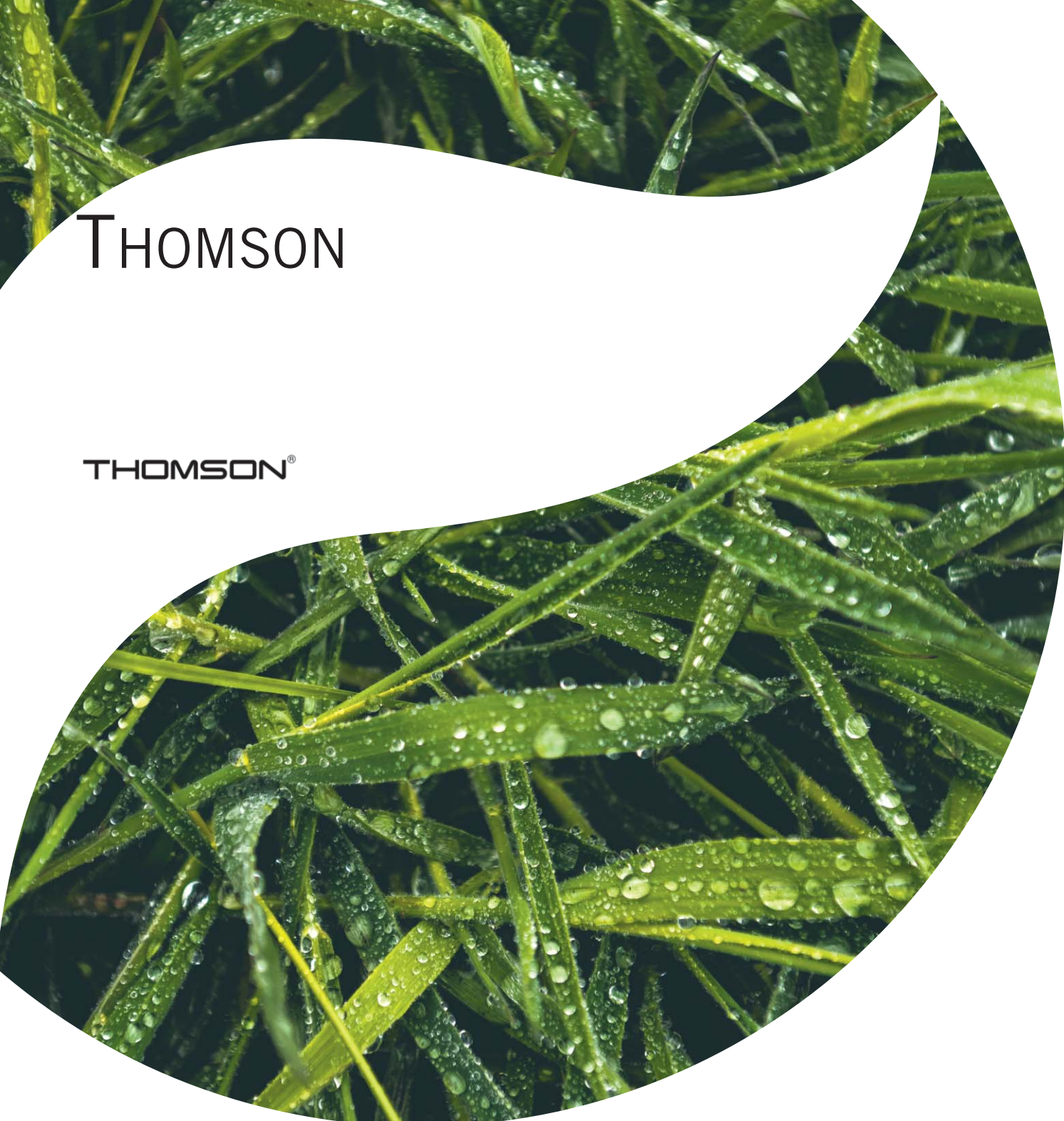

THOMSON

THOMSON®



★dsb★

SEMPLICEMENTE BICI

Covert Dropper Seatpost

€
549,00

SPECIFICHE

Reggisella telescopico da 125 a 150mm di escursione e con passaggio interno del cavo.
Ø 30,9 - 31,6mm.



THOMSON

Masterpiece

SPECIFICHE

Reggisella come il modello Elite ma con 40g in meno. Lunghezze 350mm. Dritto e arretrato.

Diametri 27,2, 30,9, 31,6mm.

COLORI

Black, Silver.



€
189,90

Elite X2

SPECIFICHE

Attacco manubrio.

COLORI

Black, Silver.



€
99,90

Elite

SPECIFICHE

Da tutti considerato il miglior reggisella al mondo. Lunghezza fino a 400mm.

COLORI

Black, Silver.



€
99,90

Elite X4

SPECIFICHE

Attacco manubrio.

COLORI

Black, Silver.



€
99,90

Collarino reggisella

SPECIFICHE

Diametri 31,8 - 34,9 - 36,4mm.

COLORI

Black, Silver.



€
39,90

Frontalino Elite X4 + tappo

SPECIFICHE

Frontalino per attacco manubrio Elite X4.

COLORI

Blu, Oro, Rosso.



€
34,90

Downhill

€
119,90

SPECIFICHE

Manubrio in alluminio.

Larghezza e rise: 780 mm x 12 mm. Peso 295g.



Carbon Flat

€
199,90

SPECIFICHE

Manubrio in carbonio piatto per le 29".

Larghezza e rise: 730 mm x 6°.

Peso 185g.



Carbon Rise

€
199,90

SPECIFICHE

Manubrio in carbonio rise 12mm.

Larghezza e rise 730 mm x 6°.

Peso 210g.



Titanium Flat

€
349,90

SPECIFICHE

Manubrio in titanio piatto per le 29".

L'esclusività assoluta.

Peso 295g.



Carbon Road + Versione Ciclocross

€
349,90

SPECIFICHE

Diametro 27,2 - 30,9 - a Mis. 40-42-44-46 CC.

Peso 195g + 5g per ogni misura 31,6.



TROY LEE DESIGNS



★dsb★

SEMPLICEMENTE BICI

Purtroppo le foto della nuova collezione possono essere pubblicate solo dopo il lancio ufficiale da parte di Troy Lee Designs.

Casco D3 Carbonio	€ 629,00	Method Knee	€ 139,00	Maglia Sprint Elite	€ 89,90
Casco D3 Composite	€ 479,00	Raid Knee	€ 169,00	Maglia Sprint	€ 64,90
Casco D3 Fiberlite	€ 299,00	Raid Elboe	€ 139,00	Maglia Ruskus	€ 129,90
Casco A2 Mips	€ 239,00	Short 7605	€ 119,00	Maglia Ace Base Laywer	€ 44,90
Casco A2 Mips Decoy	€ 219,00	Short 5605	€ 104,90	Pantaloncini Ace	€ 129,90
7855 Long Sleeve	€ 239,00	Guanti Ace	€ 49,90	Pantaloncini Ruskus	€ 139,90
7850 Short Sleeve	€ 169,00	Guanti Air	€ 39,90	Pantaloncini Skyline Air	€ 129,90
3900 Protection Vest	€ 149,00	Guanti XC	€ 39,90	Skyline	€ 109,90
Elbow Guard 5550	€ 104,90	Guanti Sprint	€ 35,90	Moto	€ 149,90
Elbow Guard 5550	€ 89,90	Maglia Ace	€ 99,90	Sprint	€ 129,90
Elbow Speed	€ 74,90	Maglia Ruskus	€ 74,90	Sprint Lunghi	€ 159,90
Knee Guard 5450	€ 119,00	Maglia Skyline Air	€ 74,90	Felpe	€ 69,90
Knee Guard 5400	€ 104,90	Maglia Skyline	€ 000,00	T-Shirt Logo	€ 29,90
		Maglia Skyline L/S	€ 89,90	Cappellini	€ 39,90



URGE

urge bike
prod
ucts



★ d s b ★

SEMPLICEMENTE BICI

Down O-Matic RR

€
309,00

SPECIFICHE

Casco da DH realizzato in materiali compositi, uno dei più leggeri di fascia alta sul mercato. Calotta esterna in fibra di vetro (80%) e fibra naturale di lino (20%) miscelato con resina termoindurente.

Certificazioni: EN 1078, CPSC 1203,

ASTM F1952, AS / NZS 2063.

Imbottitura interna completamente estraibile e lavabile. Fibbia a doppia D.

Taglie: XS (53-54cm), S (55-56cm), M (57-58cm), L (59-60cm), XL (61-62cm) Peso: 1.050g.

COLORI

Black-Silver-White, Black-Yellow-White, Black-Red-White, White-Red-Blue.



Archi-Enduro

€
309,00

SPECIFICHE

Casco integrale per l'enduro, quindi leggero, ventilato e confortevole per essere tenuto in testa tutto il giorno.

Calotta esterna in fibra di vetro (80%) e fibra di lino naturale (20%). Imbottiture rimovibili e lavabili.

Chiusura micrometrica. Certificazioni: EN 1078, CPSC 1203, ASTM F1952, AS / NZS 2063.

Taglie: XS (53-54cm), S (55-56cm),

M (57-58cm), L (59-60cm),

XL (61-62cm)

Peso 990g.

COLORI

Black-White, White-Black, Black, Blue-Red-White, Silver-Orange-White



Archi-Enduro RR+

€
409,00

SPECIFICHE

Casco Archi-Enduro completo di mascherina.

BombAir

€
219,00

SPECIFICHE

Casco integrale.

COLORI

Blue/Orange, Black, Blue/Green, White.



Drift

€
89,90

SPECIFICHE

È il casco Urge di primo prezzo ma con le caratteristiche ideali per i rider appassionati di Enduro, Freeride, DH.

Visiera ABS regolabile. Guscio leggero in policarbonato, ampie prese d'aria.

Standard: CE/CPSC/AS

Peso: 929g.

Taglie: XS, S, M, L, XL

COLORI

Black, White, Red, Green.



Endur-o-Matic 2 MIPS

€
199,90

SPECIFICHE

Casco da Enduro. Struttura interna a gabbia con disegno a farfalla per una maggior resistenza agli impatti. Sistema di ventilazione che sfruttando l'effetto Venturi, espelle l'aria calda dalla testa. Certificazione CE1078. Taglie S-M (53-57). Dispositivo di sicurezza Mips.

COLORI

Black-Blue, Blue-White, Blue-Yellow, White-Grey-Red, Pink-Purple-White.



Endur-o-Matic 2

€
149,90

SPECIFICHE

Casco Endur-o-Matic 2 senza dispositivo Mips.

SeriALL

€
79,90

SPECIFICHE

Casco per Xc/All mountain. Offre un buon rapporto prezzo/prestazioni, sicurezza, comfort e ergonomia. Certificazione N1078. Sistema di chiusura personalizzabile. Imbottiture di diverso spessore. Peso 325g. Taglie S/M (54-57cm), L/XL (58-60cm).

COLORI

Red, Grey, Blue-Green, Black.



Endur O-Matic

€
99,90

TrailHead

€
64,90

SPECIFICHE

Casco In-Mold ad ampio spettro di utilizzo: sentieri tecnici, Enduro, All Mountain. Visiera rigida, flessibile e smontabile. Peso 288g. Taglie S/M e L/XL.

COLORI

Green-Blue, White-Red, Grey-Red, Black-Blue.



All-In

€
54,90

SPECIFICHE

Casco da Enduro, Am, Trail, tuttofare di primo prezzo
Certificazione CE1078 / CPSC Recycled ABS Visor.
Regolazione posteriore personalizzata.

Fornito con imbottitura
di differenti spessori.

Peso 445g.

Taglie XS/S - S/M -L/XL

COLORI

Blue-Orange, Orange,
Black, Green-Purple.



All-M

€
119,90

SPECIFICHE

Casco da All Mountain.

Certificazione CE1078.

Peso 305g.

COLORI

Orange.



SupaTrail

€
99,90

SPECIFICHE

Casco aperto da Trail/All Mountain. Realizzato con costruzione In Mould, 14 ampie feritoie di ventilazione, inserti rimovibili e lavabili, visierina integrata, regolazione posteriore custom ring. Certificazione CE1078/CPSC. Fornito con imbottitura di differenti spessori. Peso 268g. Taglie S/M (54/57cm), L/XL (58/60cm) e XXL (63cm).

COLORI

White-Black,
Black-Blue,
Black-Red.



SupaCross

€
99,90

SPECIFICHE

Casco aperto da XC/Trail.

Peso 230g.

Taglie S/M (54/57cm),

L/XL (58/60cm).

COLORI

Black/White
Yellow/Black



Activist

€
44,90

SPECIFICHE

Casco urban, certificato CE1078/CPSC.

Misure S/M, L/XL.

COLORI

Royal Blue,
Black, White,
Blue.





«Ora che sta per uscire dal negozio guardala bene, fotografala, fissala nella tua testa. Perché non sarà mai più lucida e brillante di come è adesso. E non c'è nulla di più figo...»

DISTURB # 11 • DSB 2018

I prezzi e le informazioni incluse sono puramente indicativi e possono subire variazioni in qualsiasi momento.

Vi invitiamo a voler contattare il Vostro rivenditore e/o il sito DSB www.dsb-bonandrini.com

o la DSB stessa allo 035/4824273 per avere conferma dei prezzi in essere al momento dell'eventuale acquisto.

Abbiamo cercato di mettere la massima cura nelle informazioni che trovate nel catalogo, tuttavia siamo umani e come umani facciamo sempre degli errori.

Scusateci in anticipo e per cortesia segnalateli a info@dsb-bonandrini.com

in modo da poter eventualmente mettere una rettifica sul nostro sito

www.dsb-bonandrini.com



★ d s b ★

SEMPLICEMENTE BICI



DSB srl

Via del Lavoro 7

24046 Osio Sotto (Bergamo)

Tel. e Fax +39 035 4824273

info@dsb-bonandrini.com

www.dsb-bonandrini.com



★ dsb ★

SEMPLICEMENTE. BICI